

HARBORFRONT

TRANSFER

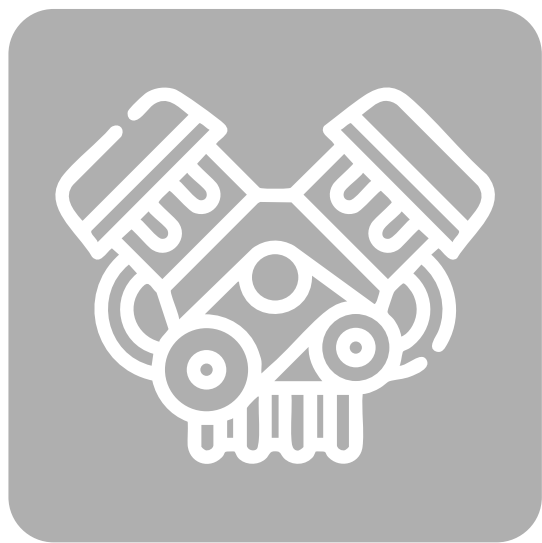

SECTION **TF**

MA

EM

LC

EC

FE

CL

MT

AT

TF

PD

FA

RA

BR

ST

RS

BT

HA

EL

IDX

CONTENTS

<p>PREPARATION2</p> <p style="padding-left: 20px;">Special Service Tools2</p> <p style="padding-left: 20px;">Commercial Service Tools3</p> <p style="padding-left: 20px;">Replacing Oil Seal.....4</p> <p style="padding-left: 40px;">Center Case Oil Seal4</p> <p style="padding-left: 40px;">Shift Shaft Oil Seal.....4</p> <p style="padding-left: 40px;">Rear Oil Seal.....5</p> <p>REMOVAL AND INSTALLATION6</p> <p>TRANSFER GEAR CONTROL7</p> <p>MAJOR OVERHAUL8</p> <p style="padding-left: 20px;">Case Components8</p> <p style="padding-left: 20px;">Gear Components9</p> <p style="padding-left: 20px;">Shift Control Components10</p> <p>DISASSEMBLY 11</p>	<p>REPAIR FOR COMPONENT PARTS.....15</p> <p style="padding-left: 20px;">Mainshaft15</p> <p style="padding-left: 20px;">Front Drive Shaft17</p> <p style="padding-left: 20px;">Counter Gear18</p> <p style="padding-left: 20px;">Main Gear18</p> <p style="padding-left: 20px;">Front Case20</p> <p style="padding-left: 40px;">Shift Shaft Oil Seal.....20</p> <p style="padding-left: 20px;">Front Case Cover20</p> <p style="padding-left: 40px;">Cover Oil Seal.....20</p> <p style="padding-left: 20px;">Bearing Retainer.....21</p> <p style="padding-left: 40px;">Oil Catcher21</p> <p style="padding-left: 20px;">Rear Case.....21</p> <p style="padding-left: 40px;">Rear Oil Seal.....21</p> <p style="padding-left: 40px;">Air Breather21</p> <p style="padding-left: 20px;">Shift Control Components22</p> <p>ASSEMBLY.....23</p> <p>SERVICE DATA AND SPECIFICATIONS (SDS)30</p> <p style="padding-left: 20px;">General Specifications.....30</p> <p style="padding-left: 20px;">Inspection and Adjustment30</p>
---	--

PREPARATION

Special Service Tools

The actual shapes of Kent-Moore tools may differ from those of special service tools illustrated here.

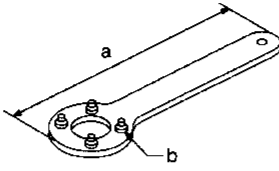
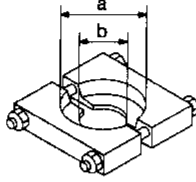
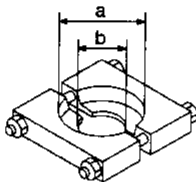
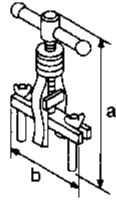
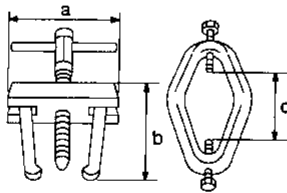
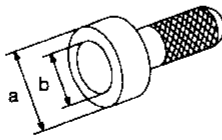
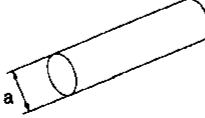
Tool number (Kent-Moore No.) Tool name	Description	
ST38060002 (J34311) Flange wrench	 <p style="text-align: center;">NT428</p>	Removing companion flange nut Installing companion flange nut a: 480 mm (18.90 in) b: Pitch dia.: 75 mm (2.95 in) Pin dia.: 10 mm (0.39 in)
ST30021000 (J22912-01) Puller	 <p style="text-align: center;">NT411</p>	Removing counter gear front bearing (Use with ST36710010) Removing L & H hub a: 110 mm (4.33 in) dia. b: 68 mm (2.68 in) dia.
ST30031000 (J22912-01) Puller	 <p style="text-align: center;">NT411</p>	Removing counter gear rear bearing (Use with ST36710010) a: 90 mm (3.54 in) dia. b: 50 mm (1.97 in) dia.
ST33290001 (J34286) Puller	 <p style="text-align: center;">NT414</p>	Removing center case oil seal Removing rear oil seal a: 250 mm (9.84 in) b: 160 mm (6.30 in)
ST33051001 (J22888) Puller	 <p style="text-align: center;">NT429</p>	Removing companion flange a: 135 mm (5.31 in) b: 100 mm (3.94 in) c: 130 mm (5.12 in)
ST30720000 ① (J25273) ② (J25405) Drift	 <p style="text-align: center;">NT115</p>	① Installing center case oil seal ② Installing rear oil seal a: 77 mm (3.03 in) dia. b: 55.5 mm (2.185 in) dia.
ST36710010 (—) Drift	 <p style="text-align: center;">NT063</p>	Removing counter gear front bearing (Use with ST30021000) Removing counter gear rear bearing (Use with ST30031000) a: 34.5 mm (1.358 in) dia.

PREPARATION

Special Service Tools (Cont'd)

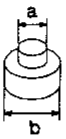
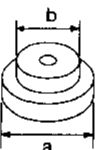
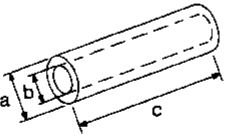
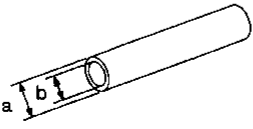
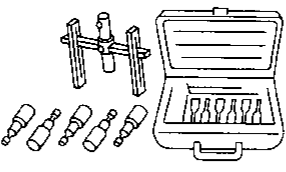
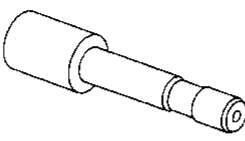
Tool number (Kent-Moore No.) Tool name	Description	
ST33061000 (J8107-2) Drift		Removing main gear bearing a: 28.5 mm (1.122 in) dia. b: 38 mm (1.50 in) dia.
ST30613000 ① (J25742-3) ② (J34339) Drift		① Installing main gear bearing ② Installing cover oil seal a: 72 mm (2.83 in) dia. b: 48 mm (1.89 in) dia.
(J35864) Drift		Installing shift shaft oil seal a: 26 mm (1.02 in) dia. b: 20 mm (0.79 in) dia. c: 150 mm (5.91 in)
(J26092) Drift		Seating counter gear assembly a: 44.5 mm (1.752 in) dia. b: 38.5 mm (1.516 in) dia.
(J34291) Shim setting gauge set		Selecting counter gear rear bearing shim
(J34291-20) Plunger-shim setting gauge		Selecting counter gear rear bearing shim

Commercial Service Tools

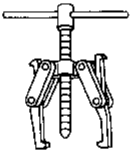
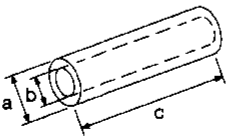
Tool name	Description	
Puller		Removing front drive shaft front bearing Removing front drive shaft rear bearing Removing main gear bearing
Drift		① Installing mainshaft rear bearing ② Installing L & H hub ① a: 50 mm (1.97 in) dia. b: 42 mm (1.65 in) dia. c: 180 mm (7.09 in) ② a: 60 mm (2.36 in) dia. b: 50 mm (1.97 in) dia. c: 60 mm (2.36 in)

PREPARATION

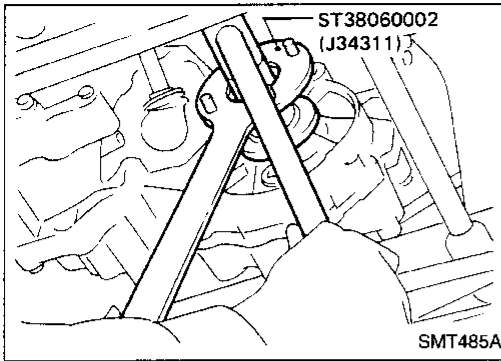

Replacing Oil Seal

CENTER CASE OIL SEAL

1. Remove front propeller shaft. Refer to PD section ("Removal and Installation", "PROPELLER SHAFT").
2. Remove companion flange nut.

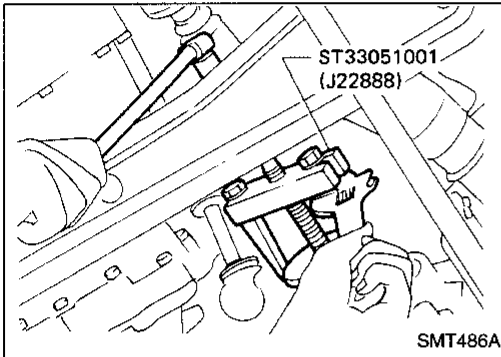

3. Remove companion flange.

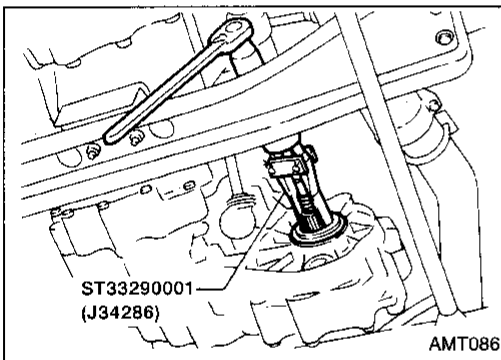

4. Remove center case oil seal.
5. Install center case oil seal.
 - **Before installing, apply multi-purpose grease to seal lip.**
6. Install companion flange.

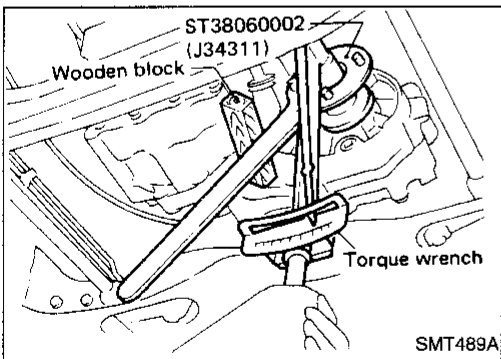

7. Tighten companion flange nut.
ⓘ: 226 - 324 N·m (23 - 33 kg·m, 166 - 239 ft·lb)
8. Install front propeller shaft. Refer to PD section ("Removal and Installation", "PROPELLER SHAFT").

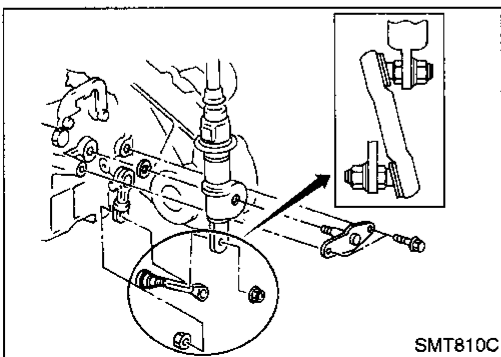

SHIFT SHAFT OIL SEAL

1. Remove front propeller shaft. Refer to PD section ("Removal and Installation", "PROPELLER SHAFT").
2. Remove companion flange. Refer to "CENTER CASE OIL SEAL", TF-4.
3. Remove transfer control lever from transfer outer shift lever. Then remove outer shift lever.

PREPARATION

Replacing Oil Seal (Cont'd)

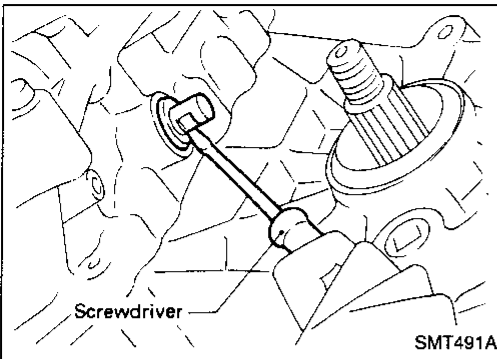

4. Remove shift shaft oil seal.
 - **Be careful not to damage cross shaft.**

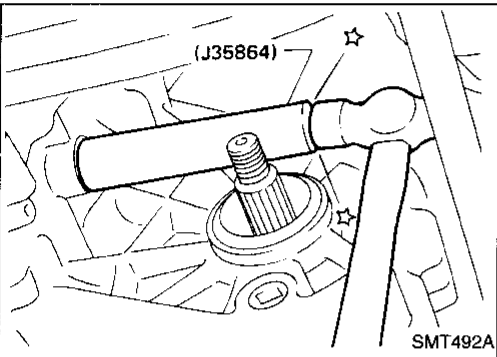

5. Install shift shaft oil seal.
 - **Before installing, apply multi-purpose grease to seal lip.**
6. Install transfer control linkage.
7. Install companion flange. Refer to "CENTER CASE OIL SEAL", TF-4.
8. Install front propeller shaft. Refer to PD section ("Removal and Installation", "PROPELLER SHAFT").

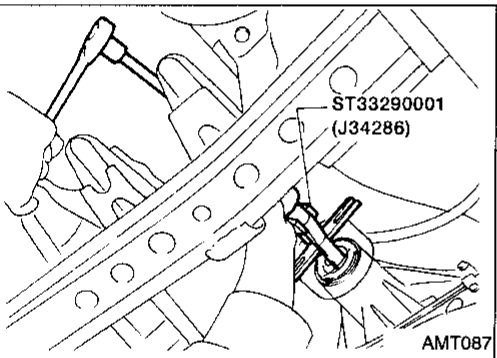

REAR OIL SEAL

1. Remove rear propeller shaft. Refer to PD section ("Removal and Installation", "PROPELLER SHAFT").
2. Remove rear oil seal.

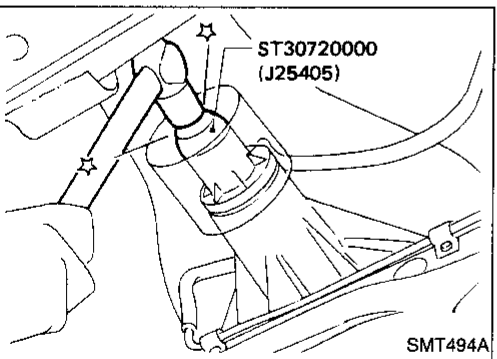

3. Install rear oil seal.
 - **Before installing apply multi-purpose grease to seal lip.**
4. Install rear propeller shaft. Refer to PD section ("Removal and Installation", "PROPELLER SHAFT").

GI
MA
EM
LC
EC
FE
CL
MT
AT
TF
PD
FA
RA
BR
ST
RS
BT
HA
EL
IDX

REMOVAL AND INSTALLATION

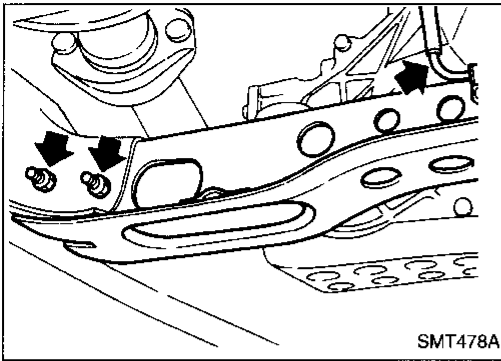

SMT478A

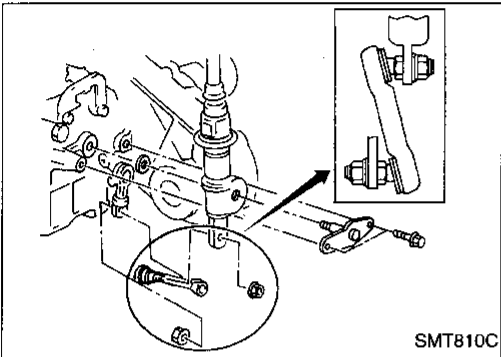

SMT810C

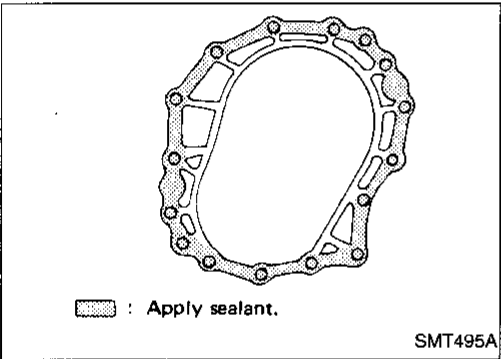

: Apply sealant.

SMT495A

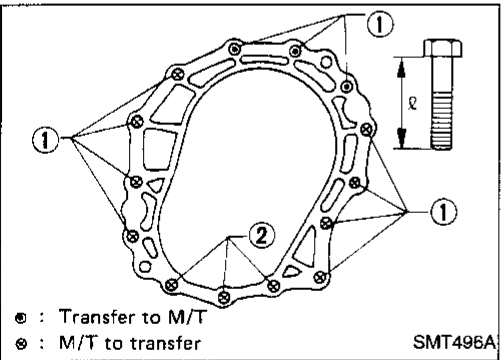

① : Transfer to M/T
 ② : M/T to transfer

SMT496A

Removal

1. Drain oil from transfer and transmission.
2. Remove front and rear propeller shaft. Refer to PD section ("Removal and Installation", "PROPELLER SHAFT"). Insert plug into rear oil seal after removing propeller shaft.
- **Be careful not to damage spline, sleeve yoke and rear oil seal, when removing propeller shaft.**
3. Remove torsion bar spring. Refer to FA section ("Torsion Bar Spring", "FRONT SUSPENSION"). Then remove second crossmember.
4. Remove transfer control lever from transfer outer shift lever.
5. Separate transfer from transmission.

WARNING:

Support transfer while removing it.

Installation

- Apply recommended sealant to mating surface of transfer case to transmission.

Recommended sealant:

Nissan genuine part (KP610-00250) or equivalent

- Tighten bolts securing transfer.

Bolt No.	Tightening torque N·m (kg·m, ft·lb)	ℓ mm (in)
①	31 - 41 (3.2 - 4.2, 23 - 30)	45 (1.77)
②	31 - 41 (3.2 - 4.2, 23 - 30)	60 (2.36)

TRANSFER GEAR CONTROL

SEC. 333

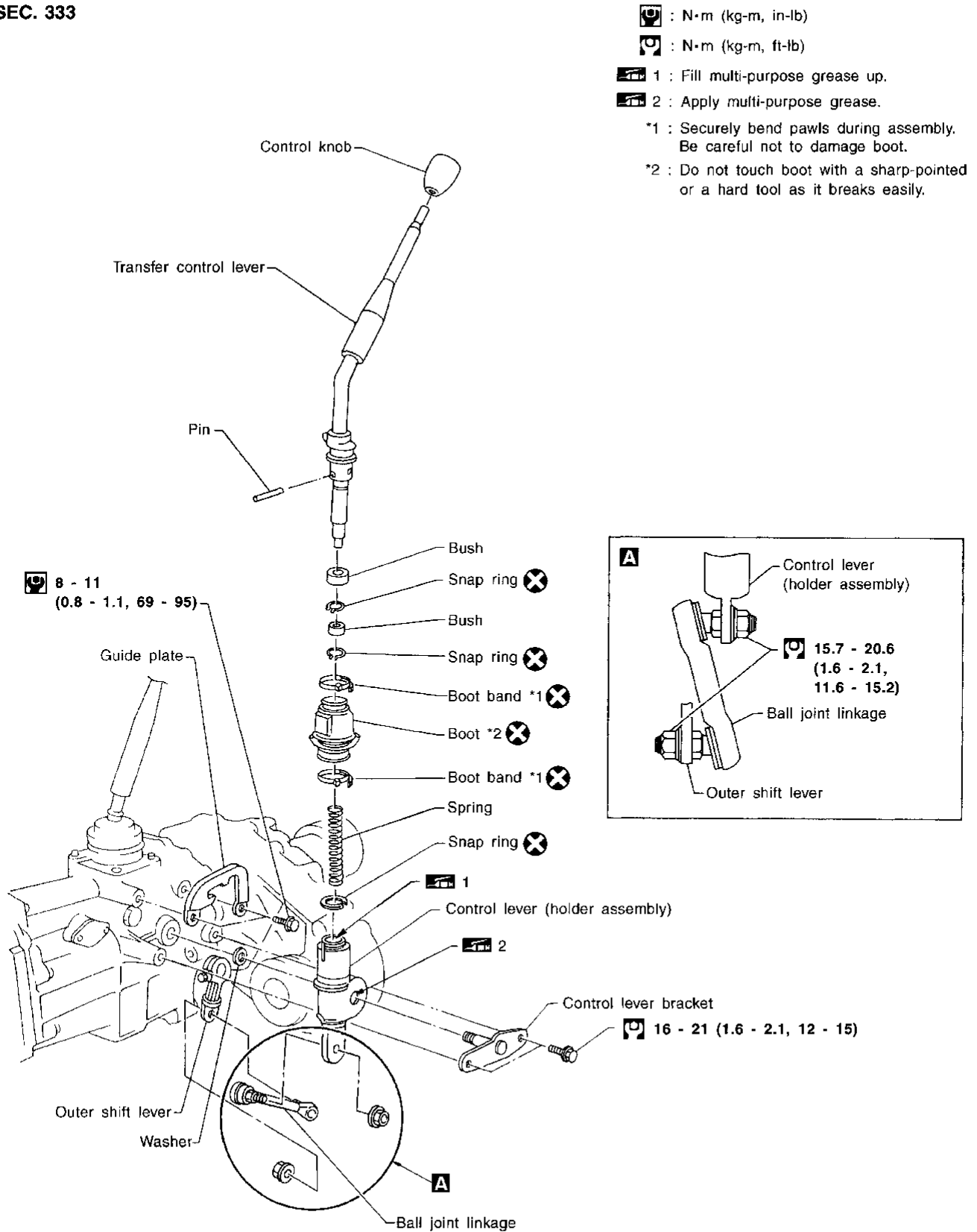

GI
MA
EM
LC
EC
FE
CL
MT
AT
TF
PD
FA
FA
BR
ST
RS
BT
FA
EL
IDX

SMT809C

Gear Components

SEC. 332

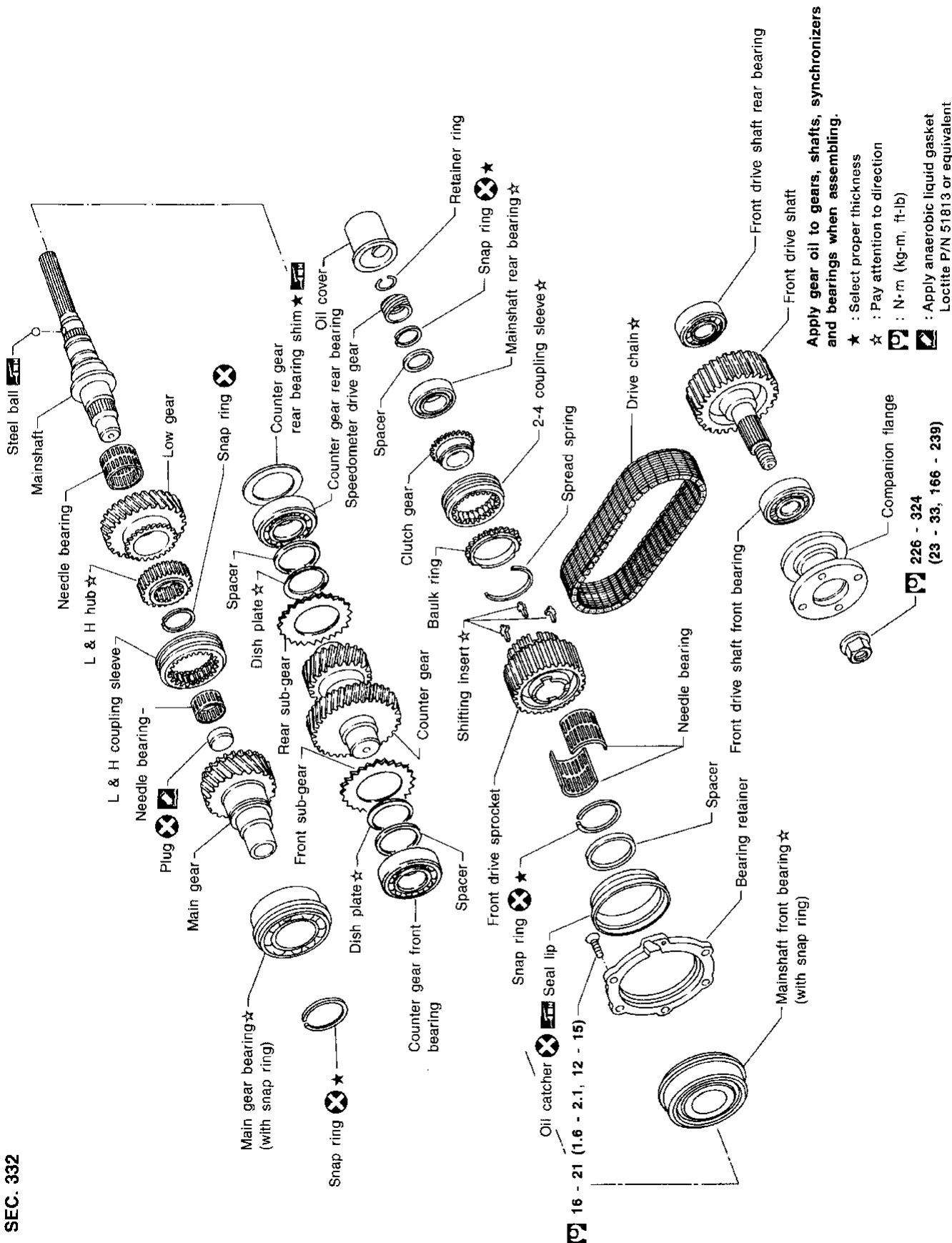

Apply gear oil to gears, shafts, synchronizers and bearings when assembling.

- ★ : Select proper thickness
- ☆ : Pay attention to direction
- : N·m (kg-m, ft-lb)
- ▣ : Apply anaerobic liquid gasket Loctite P/N 51813 or equivalent

GI
MA
EM
LC
EC
FE
CL
MT
AT
TF
PD
FA
RA
BR
ST
RS
BT
HA
EL
IDX

Shift Control Components

SEC. 333

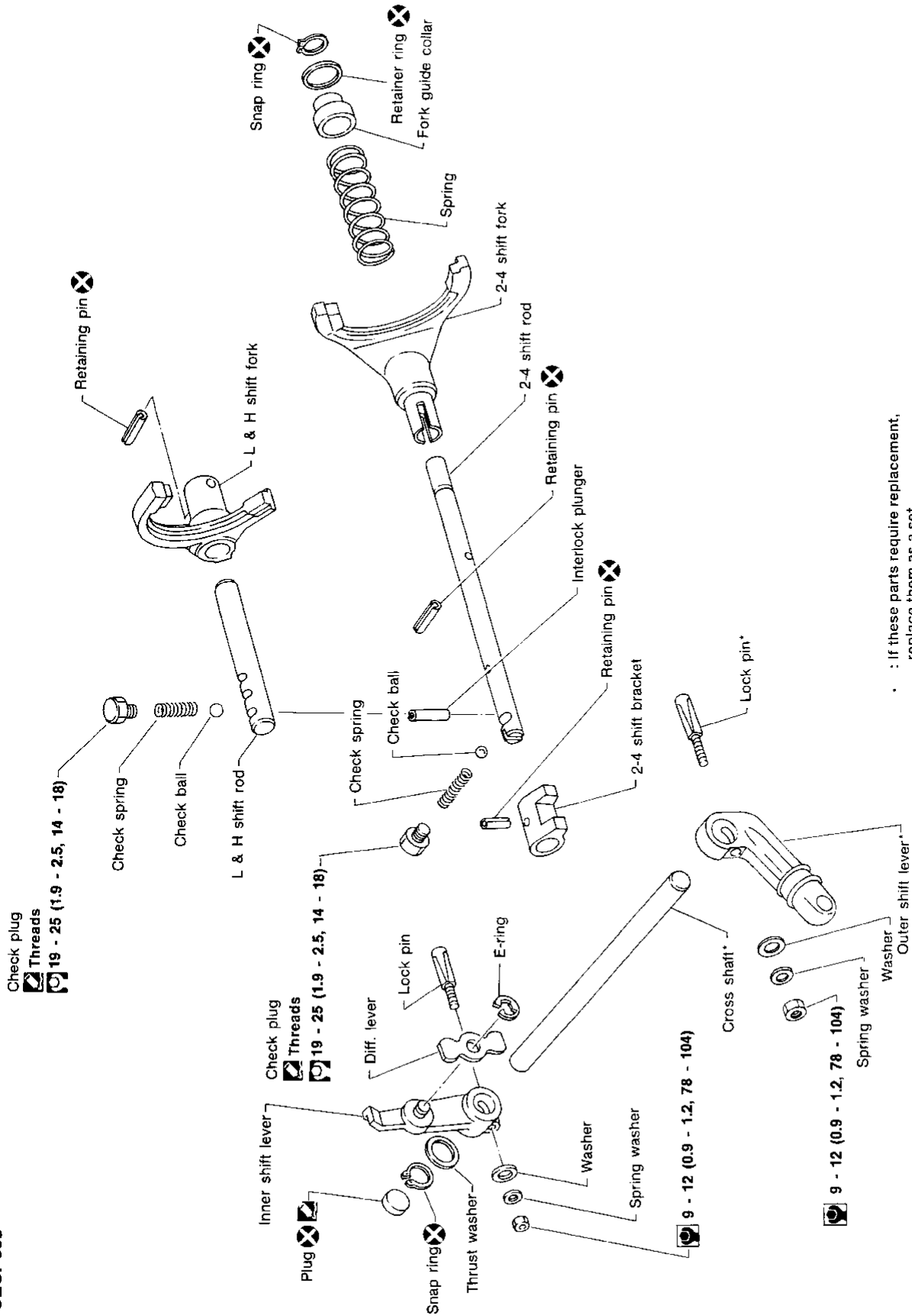

- * : if these parts require replacement, replace them as a set
- ⊗ : N·m (kg·m, in·lb)
- ⊕ : N·m (kg·m, ft·lb)
- ⊙ : Apply anaerobic liquid gasket Loctite P/N 51813 or equivalent

DISASSEMBLY

GI

MA

EM

LC

EC

FE

CL

MT

AT

TF

PD

FA

RA

BR

ST

RS

BT

HA

EL

IDX

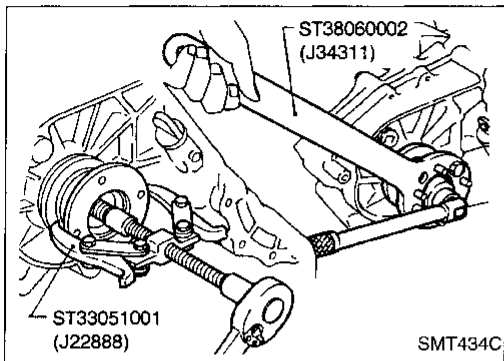

1. Remove companion flange nut.
2. Remove companion flange.

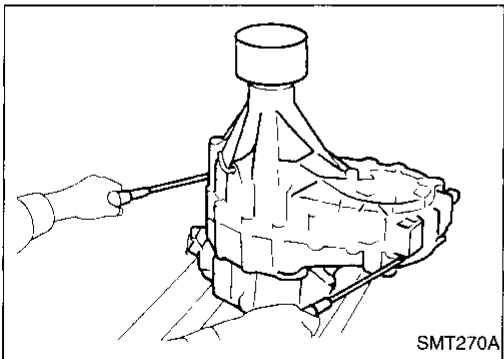

3. Remove 4WD switch.
 4. Remove rear case.
- **Be careful not to damage the mating surface.**

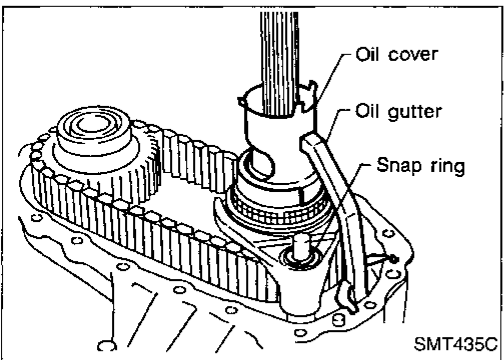

5. Remove oil cover and oil gutter.
6. Remove snap ring from 2-4 shift rod.

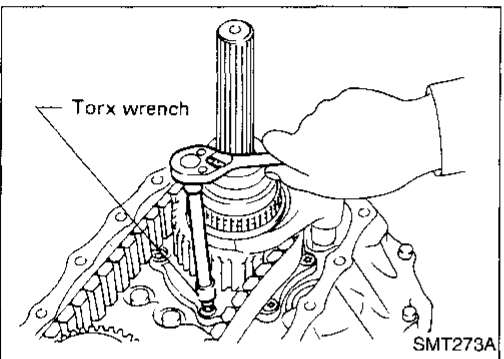

7. Remove bolts securing bearing retainer.
- **This step is necessary to remove mainshaft from center case.**

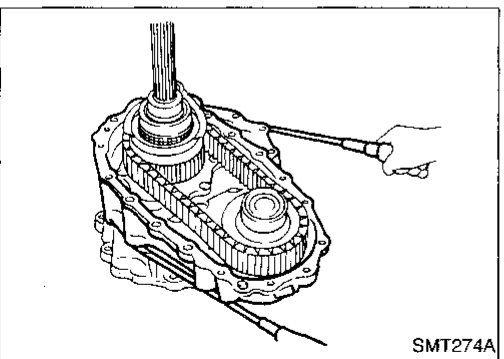

8. Remove bolts securing center case to front case, then separate center case from front case.

DISASSEMBLY

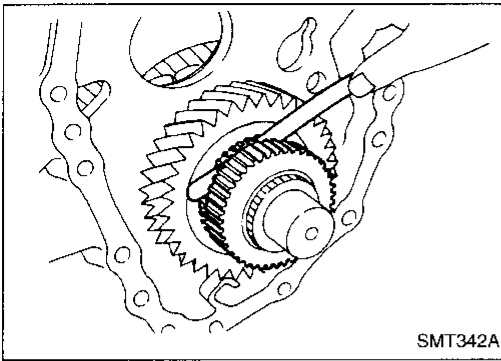

9. Measure low gear end play.

Standard:

0.2 - 0.35 mm (0.0079 - 0.0138 in)

- If end play is not within specification, check low gear and L & H hub for wear.

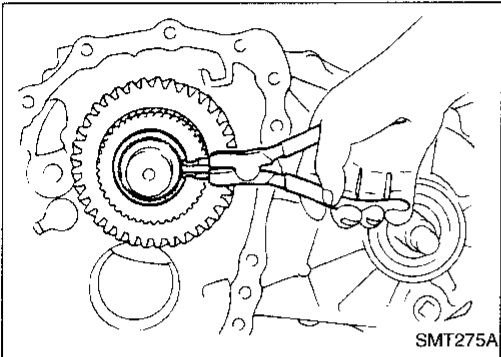

10. Disassemble center case assembly.

- a. Remove snap ring from mainshaft.

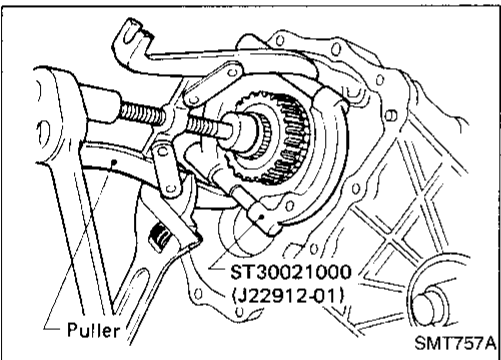

- b. Remove low gear with L & H hub.

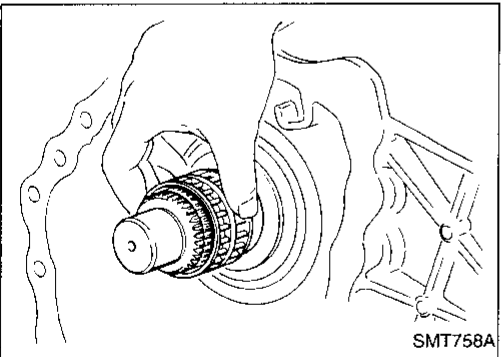

- c. Remove needle bearing from main shaft.

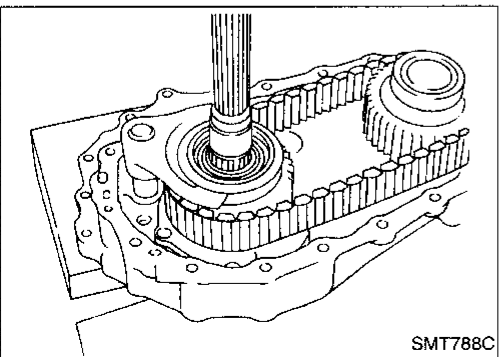

- d. Pay attention to the direction of the drive chain before removing it. (It must be reinstalled in the same direction.)

DISASSEMBLY

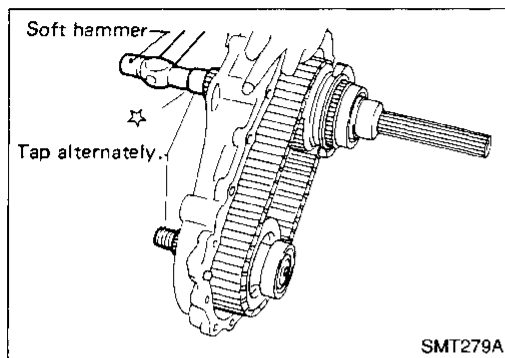

- e. Remove mainshaft, front drive and drive chain as a set by tapping front end of mainshaft and front drive shaft alternately.
- **Be careful not to bend drive chain.**

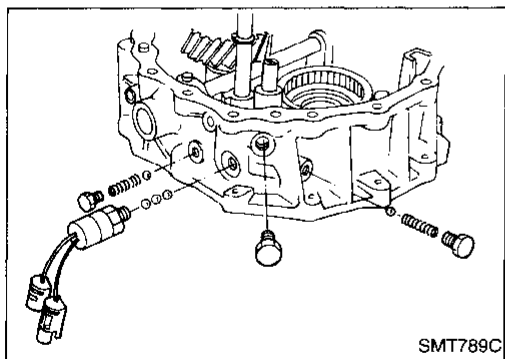

11. Disassemble front case assembly.
- a. Remove switch, plugs, check springs and balls.

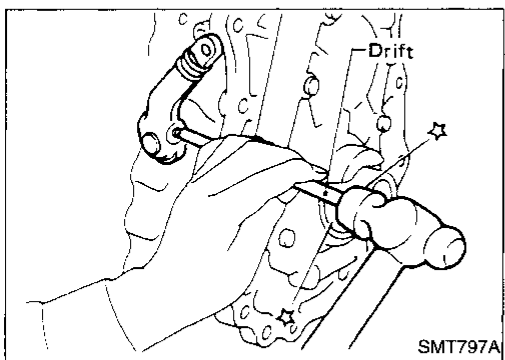

- b. Remove lock pin from outer shift lever, then remove outer shift lever.

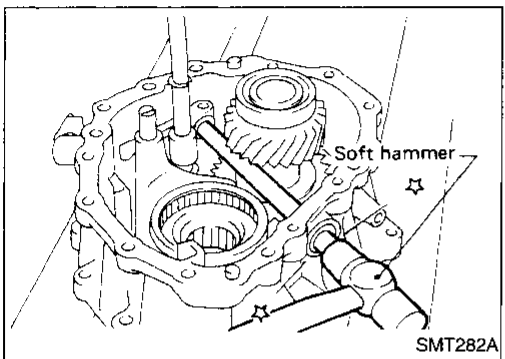

- c. Remove lock pin from inner shift lever, then drive out cross shaft and plug together.

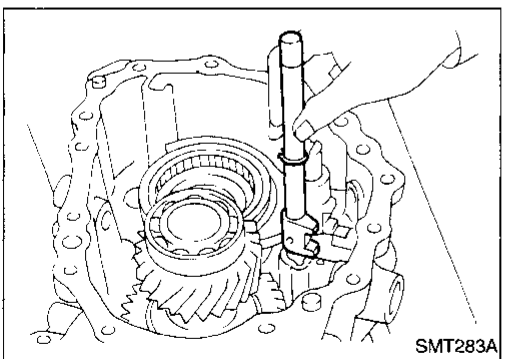

- d. Remove 2-4 shift rod.

GI
MA
EM
LC
EC
FE
CL
MT
AT
TF
PD
FA
RA
BR
ST
RS
BT
HA
EL
IDX

DISASSEMBLY

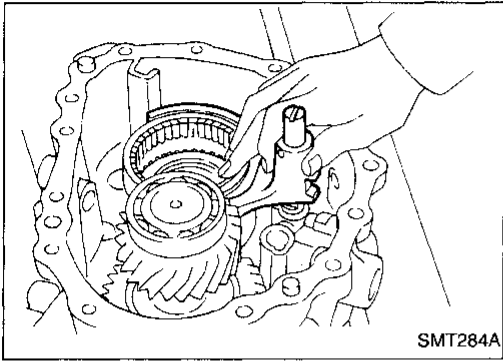

- e. Remove L & H shift rod and fork assembly with coupling sleeve.

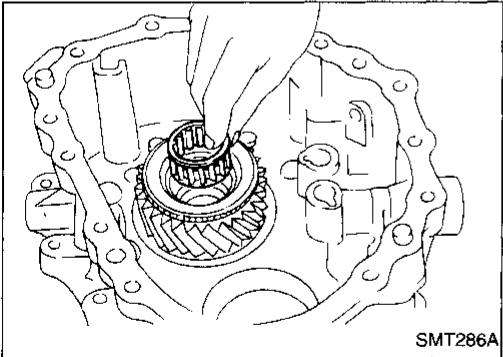

- f. Remove needle bearing from main gear.

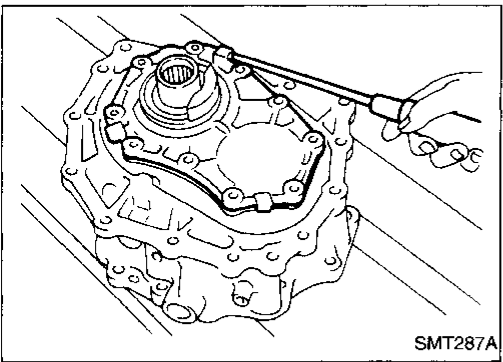

- g. Remove bolts securing front case cover, then remove case cover.

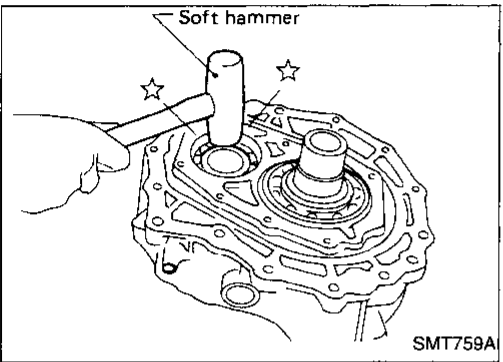

- h. Remove counter gear by tapping lightly.

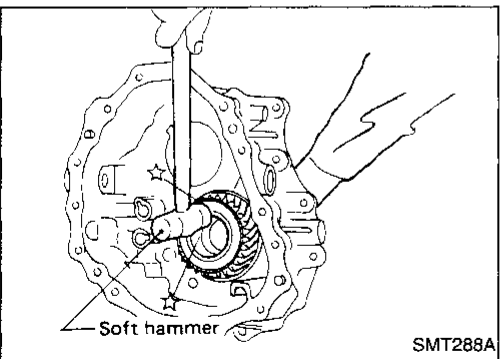

- i. Remove main gear by tapping lightly.

REPAIR FOR COMPONENT PARTS

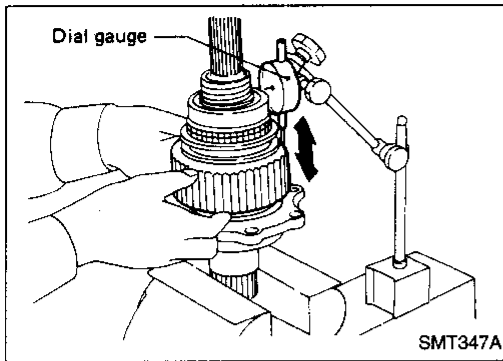

Mainshaft

DISASSEMBLY

1. Check front drive sprocket end play.

Standard:

0.2 - 0.35 mm (0.0079 - 0.0138 in)

- If end play is not within specification, check front drive sprocket and clutch gear for wear.

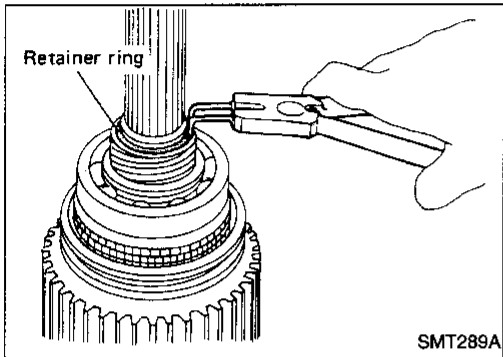

2. Remove retainer ring, speedometer drive gear and steel ball.
- Be careful not to lose the steel ball.

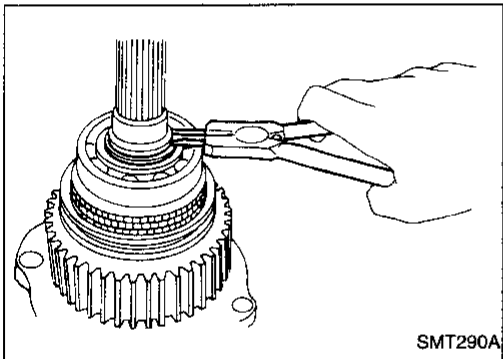

3. Remove snap ring and spacer.

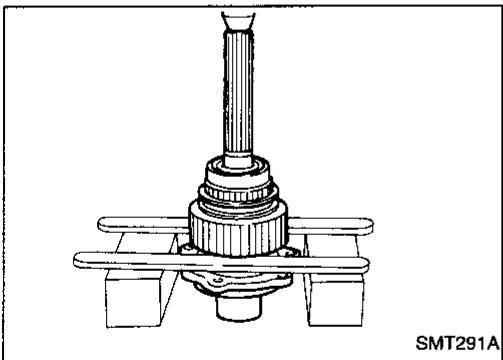

4. Use a press to remove front drive sprocket with mainshaft rear bearing and clutch gear together.
5. Remove needle bearing.

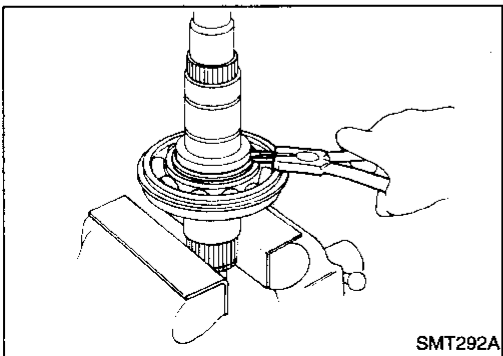

6. Remove bearing retainer, then remove snap ring and spacer.

GI

MA

EM

LC

EC

FE

CL

MT

AT

TF

PD

FA

RA

BR

ST

RS

BT

HA

EL

IDX

REPAIR FOR COMPONENT PARTS

Mainshaft (Cont'd)

7. Use a press to remove mainshaft front bearing from mainshaft.

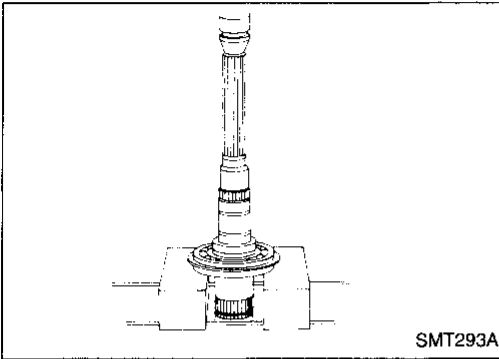

INSPECTION

Gear and shaft

- Check gears for excessive wear, chips or cracks.
- Check shaft for cracks, wear or bending.
- Check coupling sleeve for wear or damage.

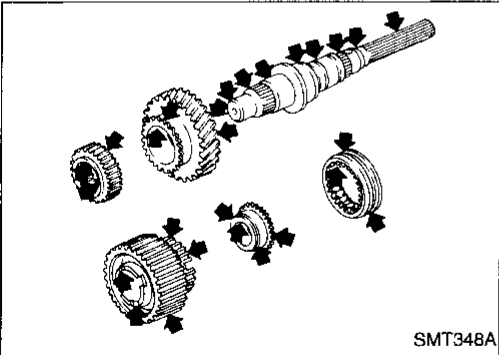

Baulk ring

- Check baulk ring for cracks or deformation.

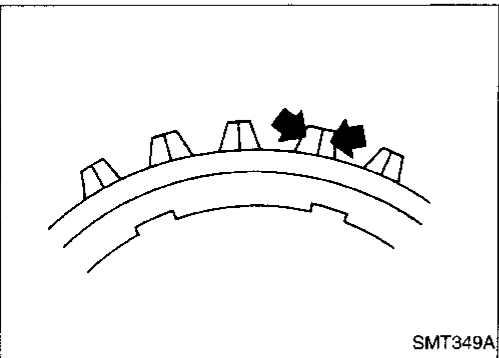

- Measure clearance between baulk ring and clutch gear.

Baulk ring to clutch gear clearance:

Refer to SDS, TF-30.

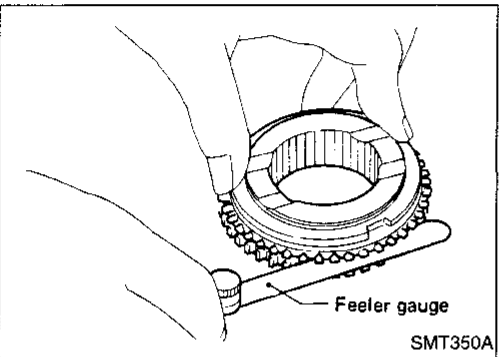

Bearing

- Make sure bearings roll freely and are free from noise, cracks, pitting or wear.

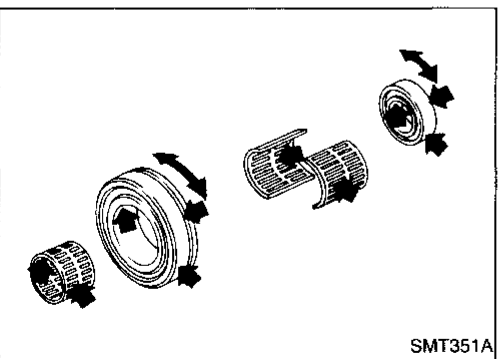

REPAIR FOR COMPONENT PARTS

Mainshaft (Cont'd)

ASSEMBLY

1. Press mainshaft front bearing onto mainshaft.
 - Pay attention to its direction.

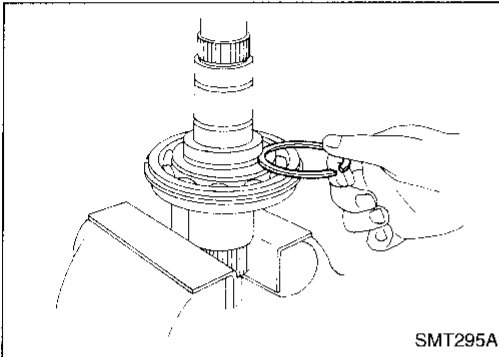
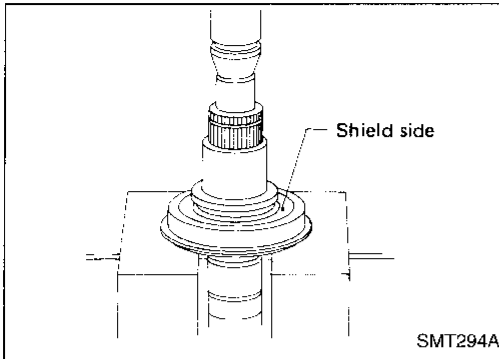

2. Install spacer.
3. Select and install snap ring with proper thickness.
 - Allowable clearance between snap ring and groove:**
0 - 0.15 mm (0 - 0.0059 in)
 - Available snap ring for mainshaft front bearing:**
Refer to SDS, TF-30.
4. For further procedures, refer to "ASSEMBLY", TF-23.

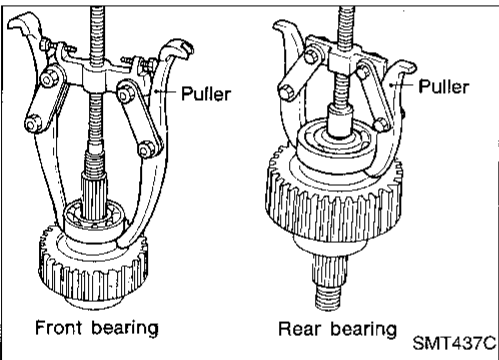

Front Drive Shaft

DISASSEMBLY

- Using a gear puller, remove front drive shaft front and rear bearings.

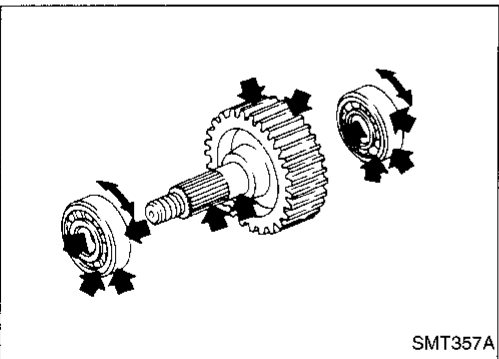

INSPECTION

Sprocket and shaft

- Check sprocket for excessive wear, chips or cracks.
- Check shaft for cracks or wear.

Bearing

- Make sure bearings roll freely and are free from noise, cracks, pitting or wear.

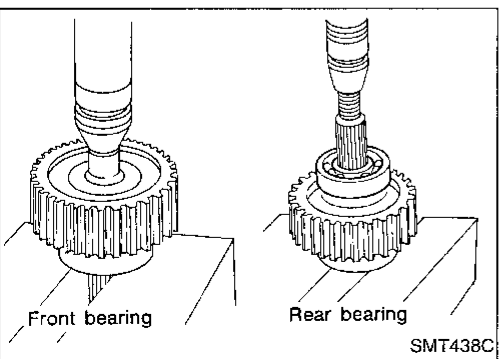

ASSEMBLY

- Press front drive shaft front and rear bearings onto front drive shaft.

GI

MA

EM

LC

EC

FE

CL

MT

AT

TF

PD

FA

RA

BR

ST

RS

BT

HA

EL

DX

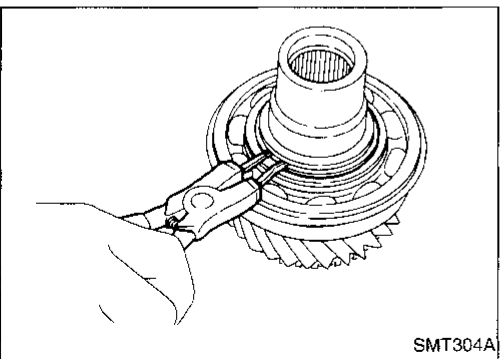
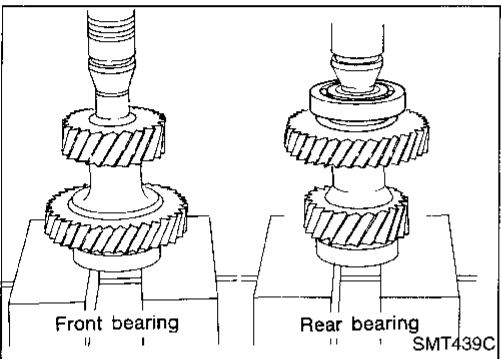
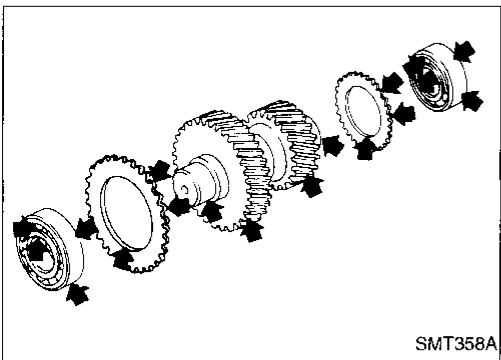
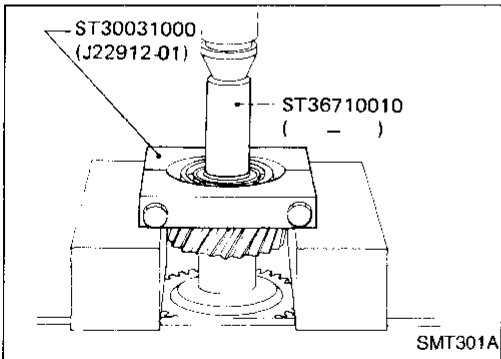
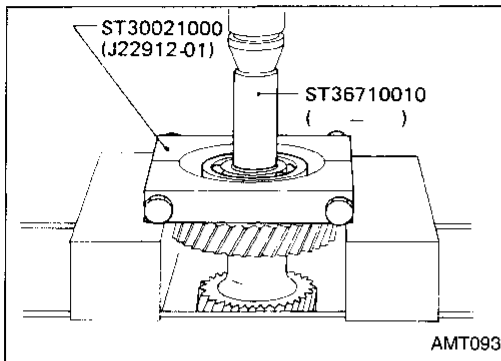

Counter Gear

DISASSEMBLY

1. Use a press to remove counter gear front bearing, then remove front sub-gear, spacer and dish plate.
2. Use a press to remove counter gear rear bearing, then remove rear sub-gear, spacer and dish plate.

INSPECTION

Gear and shaft

- Check gears for excessive wear, chips or cracks.
- Check shaft for cracks or wear.

Bearing

- Make sure bearings roll freely and are free from noise, cracks, pitting or wear.

ASSEMBLY

1. Install front sub-gear, dish plate and spacer, then press on counter gear front bearing.
2. Install rear sub-gear, dish plate and spacer, then press on counter gear rear bearing.

Main Gear

DISASSEMBLY

Main gear bearing

1. Remove snap ring.

REPAIR FOR COMPONENT PARTS

Main Gear (Cont'd)

2. Pull out main gear bearing.

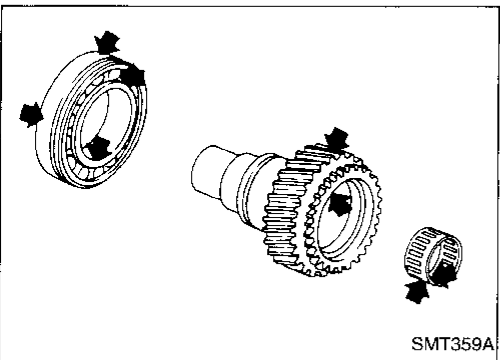
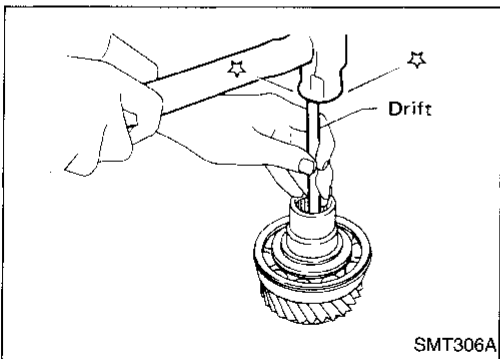
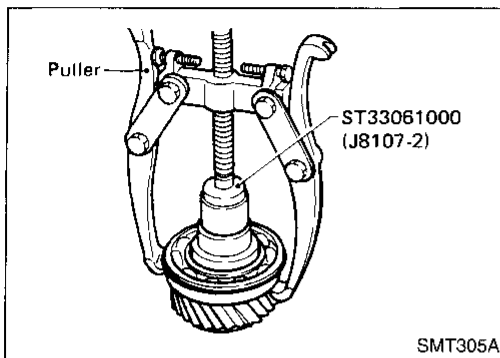

Plug

- Always replace with a new one whenever it has been removed.

INSPECTION

Gear and shaft

- Check gears for excessive wear, chips or cracks.
- Check shaft for cracks or wear.

Bearing

- Make sure bearings roll freely and are free from noise, cracks, pitting or wear.

ASSEMBLY

Main gear bearing

1. Press on main gear bearing.

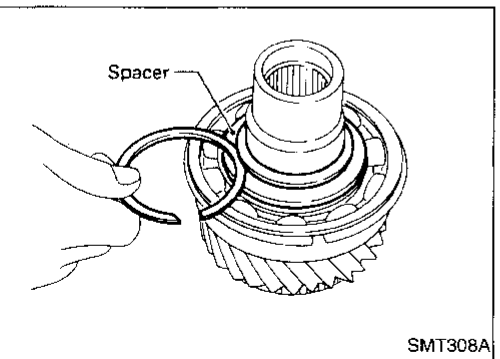
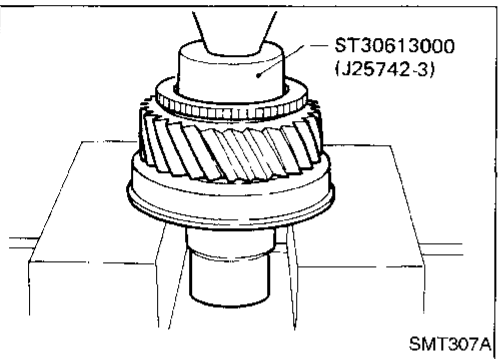

2. Select and install snap ring with proper thickness.

Allowable clearance between snap ring and groove:
0 - 0.15 mm (0 - 0.0059 in)

Available snap ring for main gear bearing:
Refer to SDS, TF-30.

GI

MA

EM

LC

EC

FE

CL

MT

AT

TF

PD

FA

RA

BR

ST

RS

BT

HA

EL

IDX

REPAIR FOR COMPONENT PARTS

Main Gear (Cont'd)

Plug

Apply sealant to plug, then install.

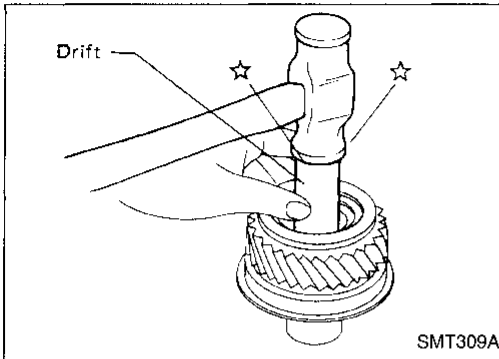

Front Case

SHIFT SHAFT OIL SEAL

Removal

- Use a screwdriver to pry out old seal.
- Be careful not to damage case.
- Always replace with a new one whenever it has been removed.

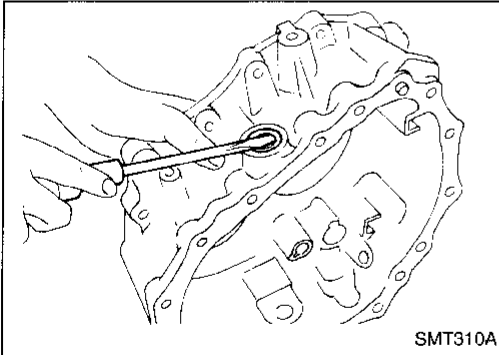

Installation

- Install new shift shaft oil seal until flush with case.
- Before installing, apply multi-purpose grease to seal lip.

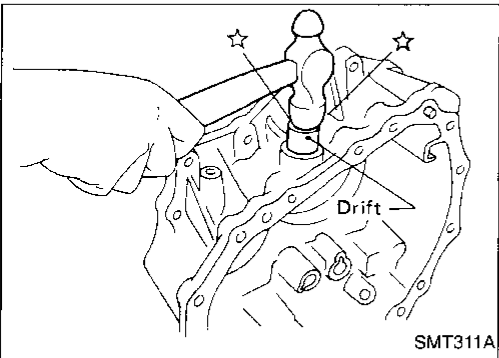

Front Case Cover

COVER OIL SEAL

Removal

- Drive out old seal from inside of front case cover.
- Be careful not to damage front case cover.

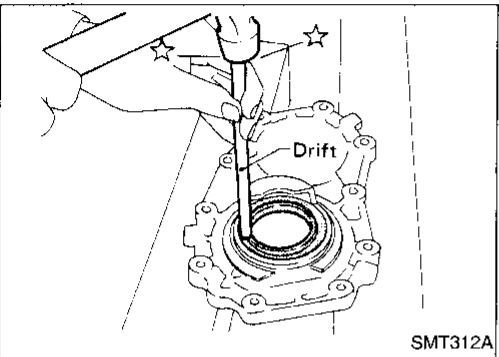

Installation

- Install new front case cover oil seal until it stops.
- Before installing, apply multi-purpose grease to seal lip.

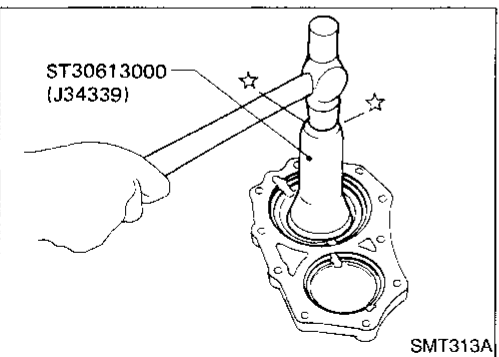

REPAIR FOR COMPONENT PARTS

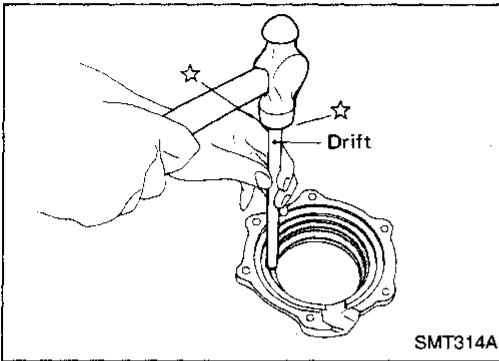

Bearing Retainer

OIL CATCHER

Removal

- Drive out oil catcher from inside of bearing retainer.
- Be careful not to damage bearing retainer.

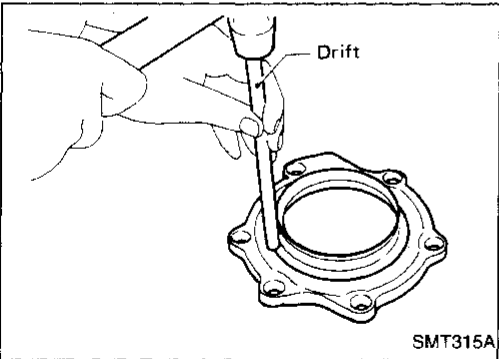

Installation

- Install oil catcher until it stops.
- Be careful not to damage or distort oil catcher or bearing retainer.
- Before installing, apply multi-purpose grease to seal lip.

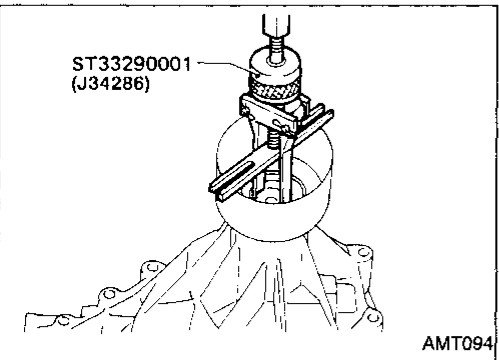

Rear Case

REAR OIL SEAL

Removal

- Pull out rear oil seal.

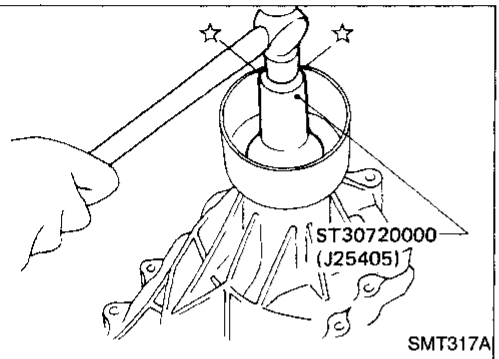

Installation

- Install new rear oil seal until it stops.
- Before installing, apply multi-purpose grease to seal lip.

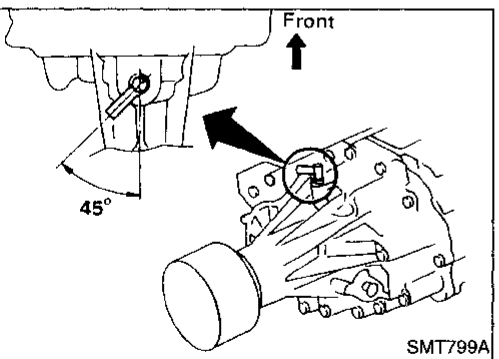

AIR BREATHER

Install as shown in illustration.

GI

MA

EM

LC

EC

FE

CL

MT

AT

TF

PD

FA

RA

BR

ST

RS

BT

HA

EL

IDX

REPAIR FOR COMPONENT PARTS

Shift Control Components

INSPECTION

- Check contact surface and sliding surface for wear, scratches, projections or other faulty conditions.

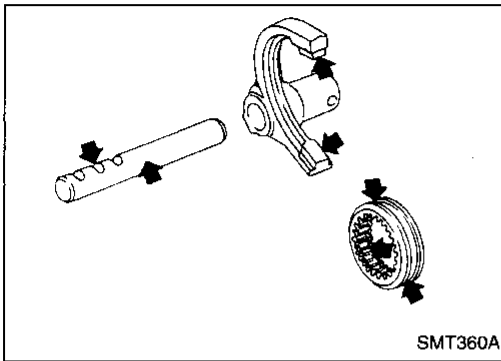

L & H SHIFT ROD & FORK

- Assemble as shown in illustration.

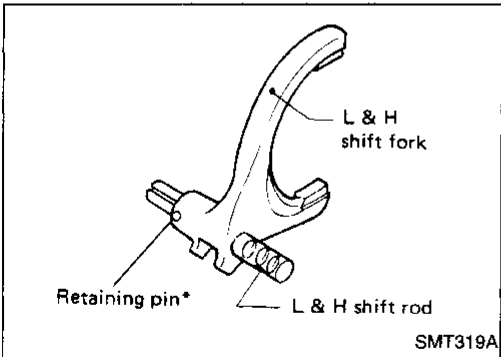

* Retaining pin is the same size as the one for 2-4 shift rod.

2-4 SHIFT ROD & FORK

- Assemble as shown in illustration.

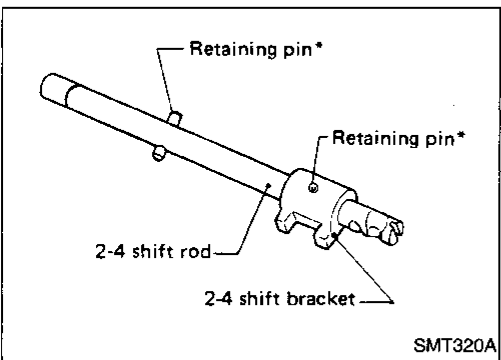

* Retaining pins are the same size.

- Pay attention to the direction of fork guide collar.

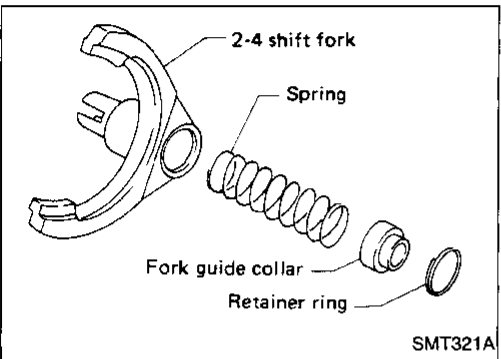

ASSEMBLY

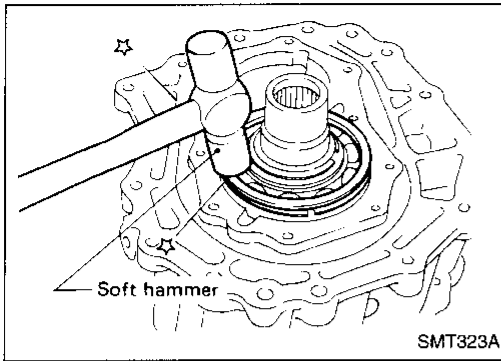

1. Assemble front case.
 - a. Install main gear assembly by tapping lightly.

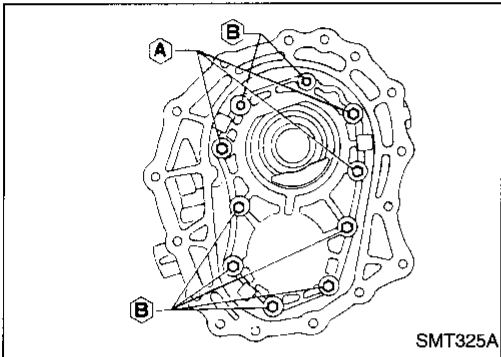

- b. Apply sealant to the mating surface and bolts of front case cover, then attach it to the front case.

- These ten bolts should be coated with sealant.

Bolts A:

☐: 16 - 21 N·m (1.6 - 2.1 kg-m, 12 - 15 ft-lb)

Bolts B:

☐: 19 - 24 N·m (1.9 - 2.4 kg-m, 14 - 17 ft-lb)

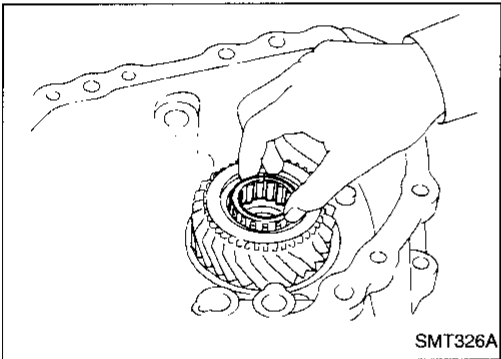

- c. Apply gear oil to needle bearing and install it into main gear.

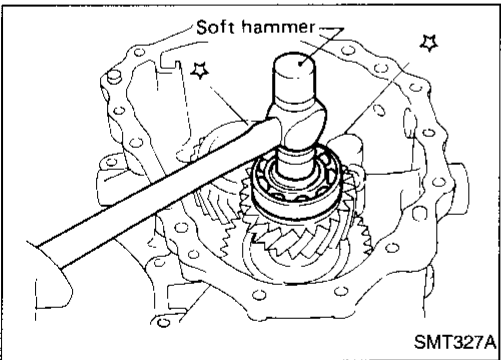

- d. Install counter gear assembly by tapping lightly.

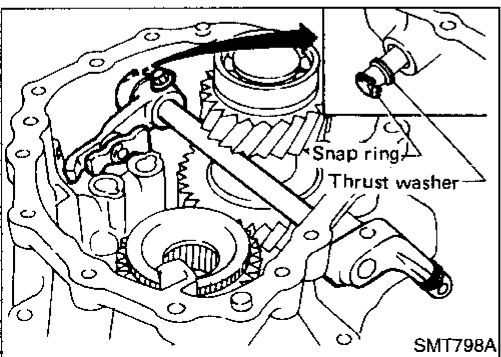

- e. Install cross shaft and inner shift lever.

- When replacing cross shaft, outer shift lever or outer shift lever lock pin, replace them as a set.

GI

MA

EM

LC

EC

FE

CL

MT

AT

TF

PD

FA

RA

BR

ST

RS

BT

HA

EL

IDX

ASSEMBLY

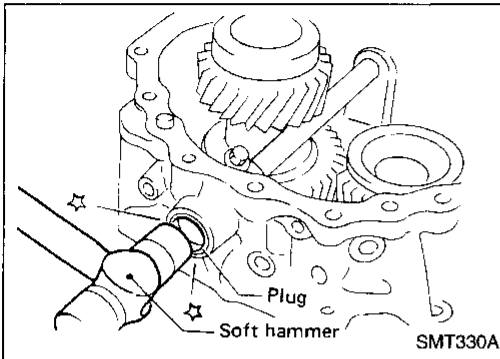

f. Apply sealant to plug, then install it into front case.

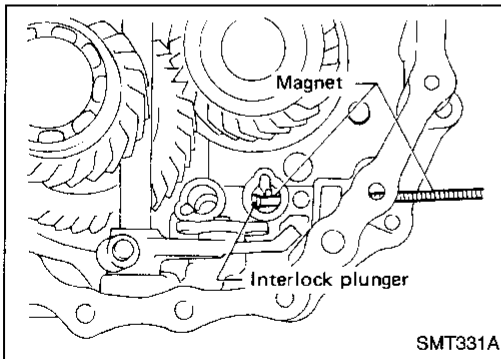

g. Insert interlock plunger into front case.

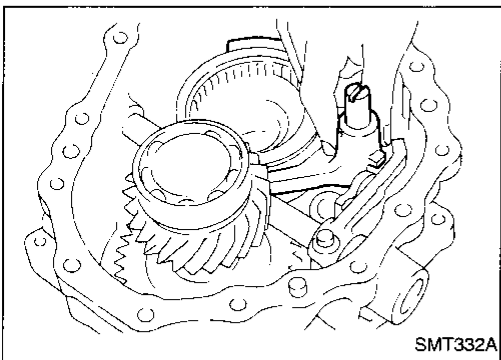

h. Install L & H shift rod and fork assembly with coupling sleeve.

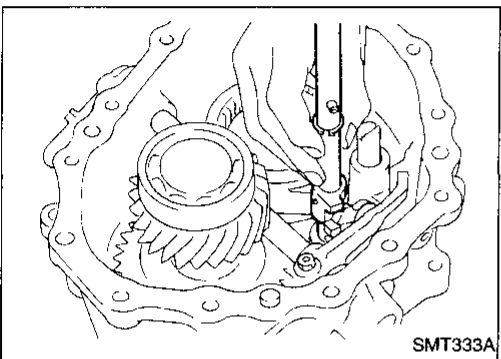

i. Install 2-4 shift rod.

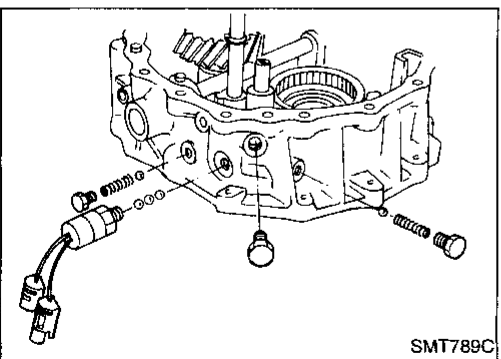

j. Install switches, check balls, check springs and plugs.
● **Apply sealant to switches and plugs.**

ASSEMBLY

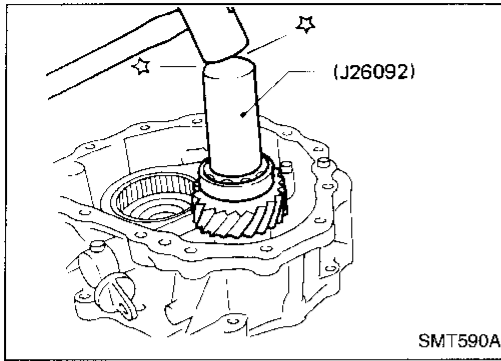

2. Select counter gear rear bearing shim.
 - a. Seat counter gear assembly.

GI

MA

EM

LC

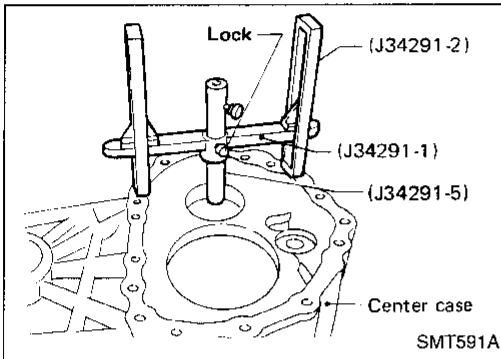

- b. Place J34291-1 (bridge), J34291-2 (legs) and J34291-5 (gauging cylinder) on machined surface of center case, allowing gauging cylinder to rest on top outer portion of counter gear rear bearing. Lock gauging cylinder in place.

EC

FE

CL

MT

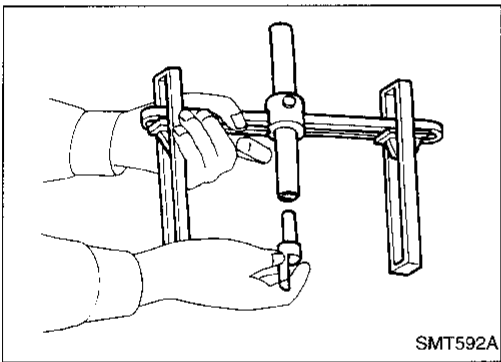

- c. Insert J34291-20 (gauging plunger) into J34291-5 (gauging cylinder).

AT

TF

PD

FA

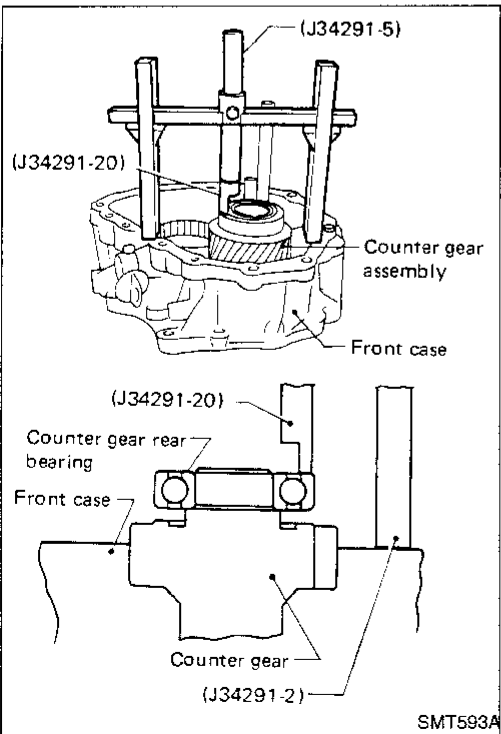

- d. Place bridge, legs, gauging cylinder and gauging plunger onto machined surface of front case assembly, allowing gauging plunger to drop until it contacts counter gear rear bearing mating surface.

RA

BR

ST

RS

BT

HA

EL

IDX

ASSEMBLY

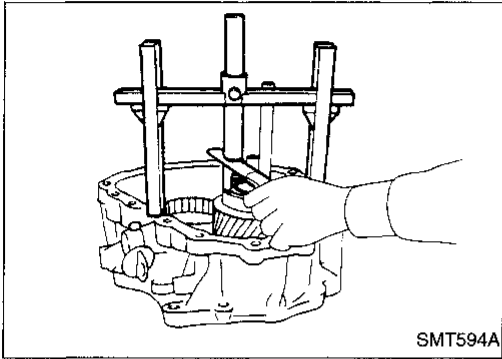

- e. Lock gauging plunger in place and use feeler gauge to measure clearance between gauging cylinder and gauging plunger.
- f. Use measured distance to select correct counter gear rear bearing shim.

Allowable counter gear clearance:
0 - 0.2 mm (0 - 0.008 in)

Available counter gear rear bearing shim:
Refer to SDS, TF-30.

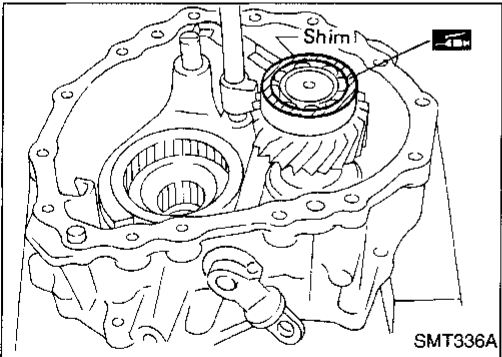

3. Place suitable shim with grease on counter gear rear bearing.
4. Apply gear oil to each part in front case.

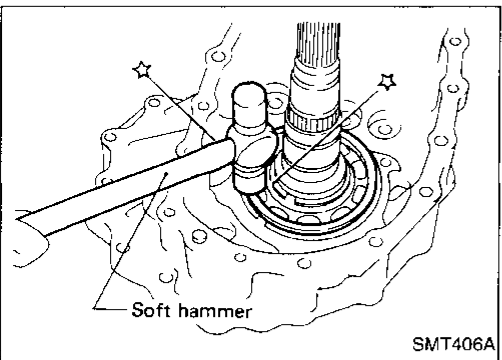

5. Assemble center case assembly.
 - a. Install mainshaft on center case by tapping lightly.
 - **Apply gear oil to mainshaft front bearing.**

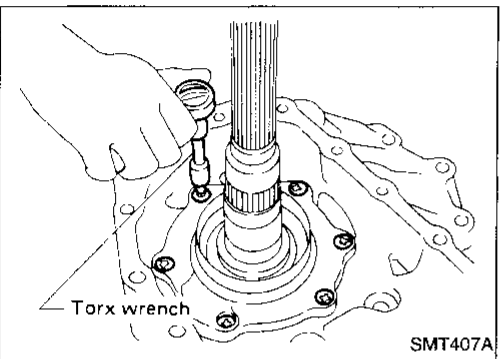

- b. Install bearing retainer.
 - Ⓜ: 16 - 21 N·m (1.6 - 21 kg-m, 12 - 15 ft-lb)

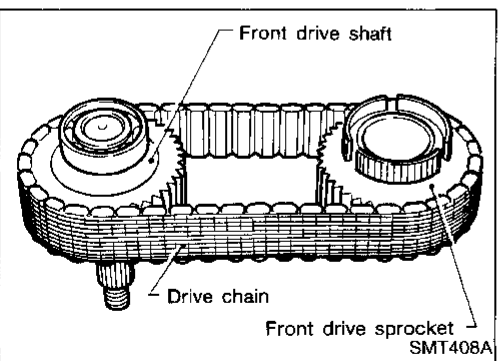

- c. Put drive chain onto the front drive sprocket and front drive shaft, and then put them in center case.
 - **Be sure to install drive chain in same direction as removed.**

ASSEMBLY

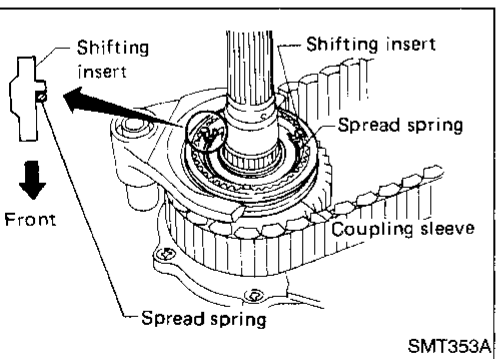
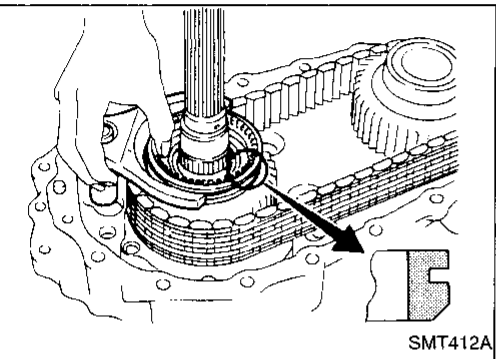
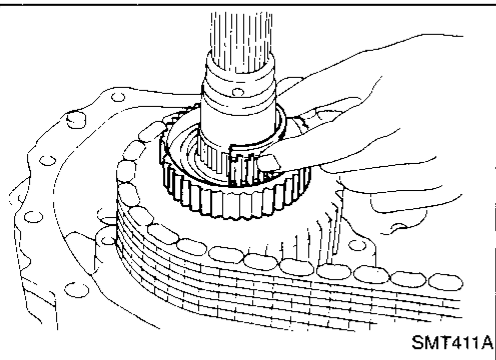
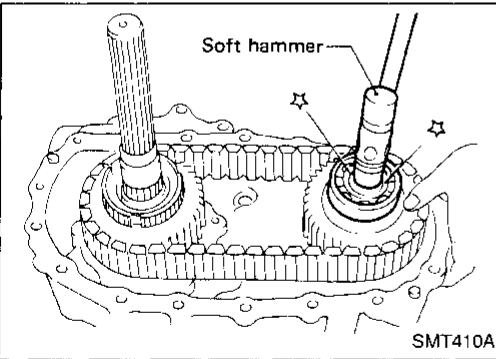
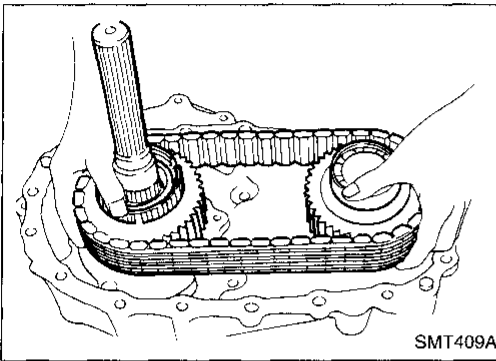

- d. Install front drive shaft by tapping lightly.
- **Make sure shafts are aligned in the case.**

- e. Apply gear oil to needle bearings and install them into front drive sprocket.
- **These needle bearings will be installed more easily if front drive sprocket is rotated while installing them.**

- f. Install 2-4 coupling sleeve with 2-4 shift fork.
- **Pay attention to the direction of the coupling sleeve.**

- g. Install shifting inserts and spread spring.
- **Pay attention to the direction of shifting inserts.**

CI
MA
EM
LC
EC
FE
CL
MT
AT
TF
PD
FA
RA
BR
ST
RS
BT
HA
EL
IDX

ASSEMBLY

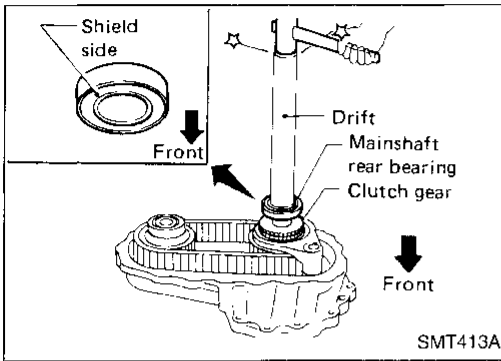

- h. Install baulk ring, then install clutch gear and mainshaft rear bearing.
- **Place wooden block under mainshaft in order to protect mainshaft front bearing.**

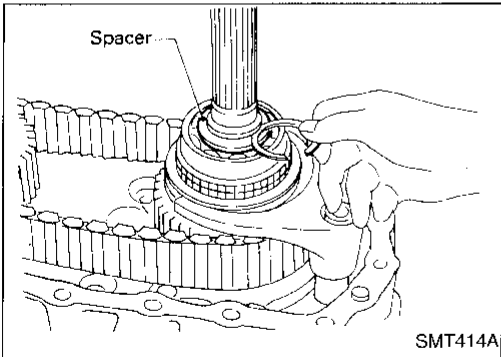

- i. Install spacer.
- j. Select and install snap ring with proper thickness.
- Allowable clearance between snap ring and groove:**
0 - 0.15 mm (0 - 0.0059 in)
- Available snap ring for mainshaft rear bearing:**
Refer to SDS, TF-30.

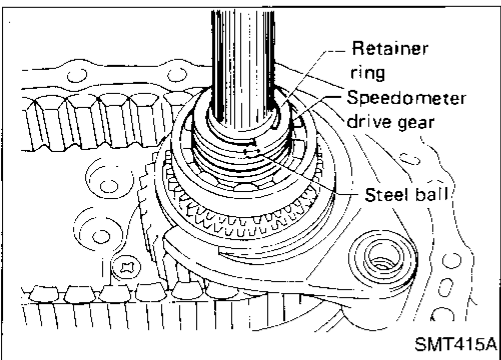

- k. Install steel ball, speedometer drive gear and retainer ring.
- **Steel ball is the smallest check ball for this unit.**

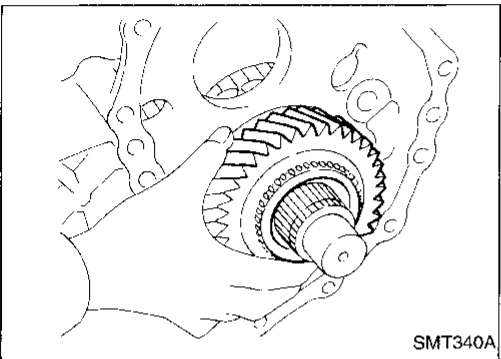

- l. Install low gear and bearing onto mainshaft.
- **Apply gear oil to needle bearing.**

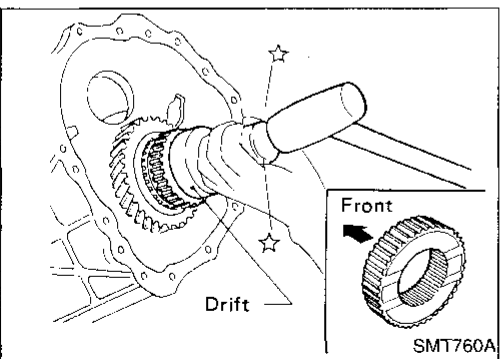

- m. Install L & H hub and snap ring onto mainshaft.
- **Pay attention to the direction of L & H hub.**

ASSEMBLY

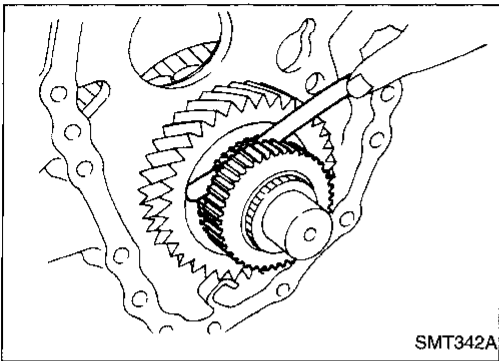

- n. Measure low gear end play.
Standard: 0.2 - 0.35 mm (0.0079 - 0.0138 in)

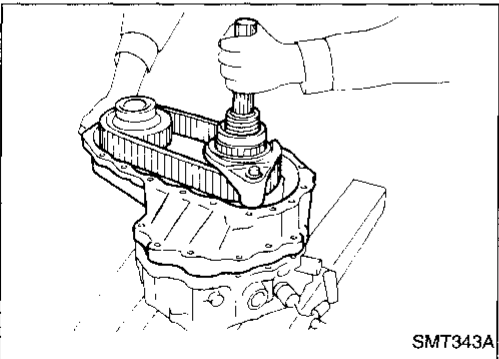

6. Apply sealant to mating surface of center case, then attach to front case and tighten bolts.

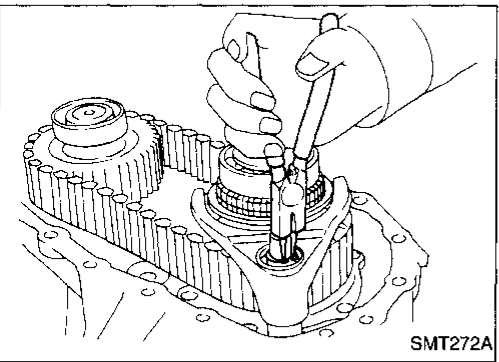

7. Install snap ring to 2-4 shift rod.

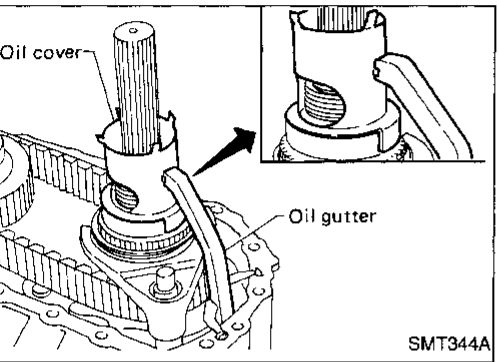

8. Install oil gutter and oil cover.
9. Apply gear oil to each part in center case.

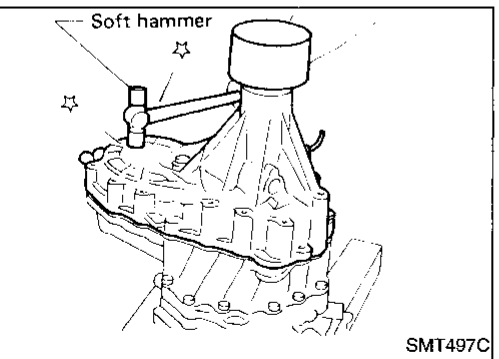

10. Apply sealant to mating surface of rear case, then attach it to center case and tighten bolts.
11. Install 4WD switch.
● Apply sealant to switch threads.

GI

MA

EM

LC

EC

FE

CL

MT

AT

TF

PD

FA

RA

BR

ST

RS

BT

HA

EL

IDX

SERVICE DATA AND SPECIFICATIONS (SDS)

General Specifications

Transfer model		TX10A	
Gear ratio	High	1.000	
	Low	2.020	
Number of teeth	Main gear	29	
	Low gear	37	
	Counter gear	High	38
		Low	24
	Front drive sprocket		41
	Front drive shaft		41
Oil capacity	ℓ (US qt, Imp qt)	2.2 (2-3/8, 2)	

Inspection and Adjustment

GEAR END PLAY

Unit: mm (in)

Front drive sprocket	0.2 - 0.35 (0.0079 - 0.0138)
Low gear	0.2 - 0.35 (0.0079 - 0.0138)
Counter gear	0 - 0.2 (0 - 0.008)

CLEARANCE BETWEEN BAULK RING AND CLUTCH GEAR

Unit: mm (in)

Standard	Wear limit
1.0 - 1.5 (0.039 - 0.059)	0.5 (0.020)

AVAILABLE SHIM

Counter gear rear bearing

Allowable clearance	0 - 0.2 mm (0 - 0.008 in)	
Thickness mm (in)	Part number	
0.1 (0.004)	33112-C6900	
0.2 (0.008)	33112-C6901	
0.3 (0.012)	33112-C6902	
0.4 (0.016)	33112-C6903	
0.5 (0.020)	33112-33G00	
0.6 (0.024)	33112-33G01	

AVAILABLE SNAP RING

Mainshaft front bearing

Allowable clearance	0 - 0.15 mm (0 - 0.0059 in)	
Thickness mm (in)	Part number	
3.1 (0.122)	33138-73P10	
3.19 (0.126)	33138-73P11	
3.28 (0.129)	33138-73P12	

Mainshaft rear bearing

Allowable clearance	0 - 0.15 mm (0 - 0.0059 in)	
Thickness mm (in)	Part number	
1.8 (0.071)	33138-73P20	
1.89 (0.074)	33138-73P21	
1.98 (0.078)	33138-73P22	
2.07 (0.081)	33138-73P23	
2.16 (0.085)	33138-73P24	

Main gear bearing

Allowable clearance	0 - 0.15 mm (0 - 0.0059 in)	
Thickness mm (in)	Part number	
2.60 (0.102)	33114-73P00	
2.69 (0.106)	33114-73P01	
2.78 (0.109)	33114-73P02	