

REAR AXLE & REAR SUSPENSION

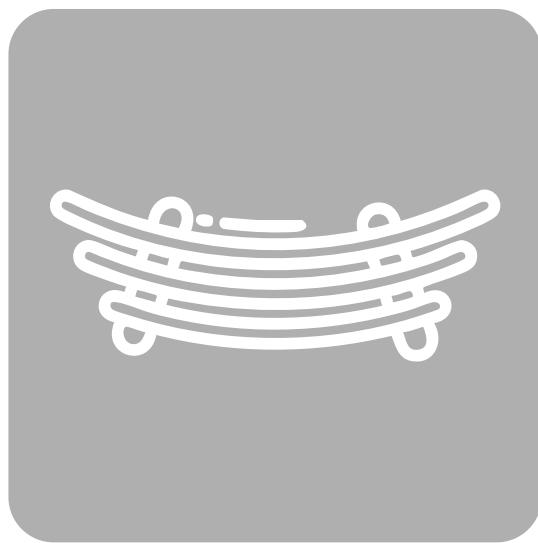

REAR AXLE & REAR SUSPENSION

SECTION **RA**

CONTENTS

PRECAUTIONS AND PREPARATION	2	REAR AXLE	5
Precautions.....	2	Components.....	5
Special Service Tools.....	2	Removal.....	5
Commercial Service Tools.....	2	Inspection.....	7
REAR AXLE AND REAR SUSPENSION	3	Installation.....	7
ON-VEHICLE SERVICE	4	REAR SUSPENSION	9
Rear Axle and Rear Suspension Parts.....	4	Shock Absorber.....	10
Rear Wheel Bearing.....	4	Leaf Spring.....	10
		SERVICE DATA AND SPECIFICATIONS (SDS)	12
		General Specifications.....	12
		Inspection and Adjustment.....	12

GI

MA

EM

LC

EC

FE

CL

MT

AT

TF

PD

FA

RA

BR

ST

RS

BT

HA

EL

IDX

PRECAUTIONS AND PREPARATION

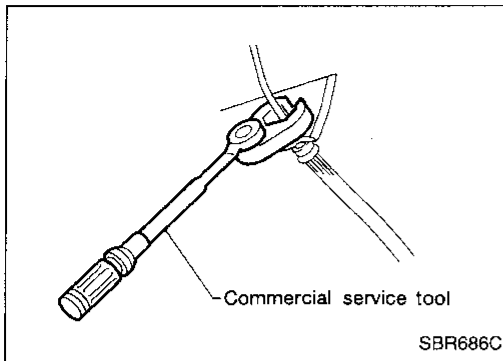

Precautions

- When installing rubber parts, final tightening must be carried out under unladen condition* with tires on ground.
- *: Fuel, radiator coolant and engine oil full. Spare tire, jack, hand tools and mats in designated positions.
- Use flare nut wrench when removing or installing brake tubes.
- After installing removed suspension parts, check wheel alignment and adjust if necessary.
- Always torque brake lines when installing.

Special Service Tools

The actual shapes of Kent-Moore tools may differ from those of special service tools illustrated here.

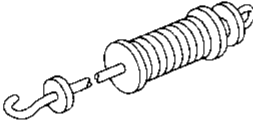
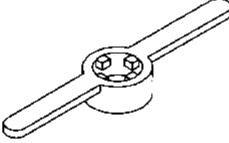
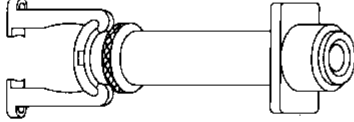
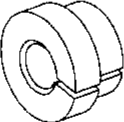
Tool number (Kent-Moore No.) Tool name	Description	
KV40101000 (J25604-01) Axle stand		Removing rear axle shaft
ST36230000 (J25840-A) Sliding hammer		Removing rear axle shaft
ST38020000 (—) Bearing lock nut wrench		Removing wheel bearing lock nut
HT72480000 (J25852-B) Rear axle shaft bearing puller		Removing wheel bearing
ST37840000 (—) Rear axle shaft guide		Installing rear axle shaft

Commercial Service Tools

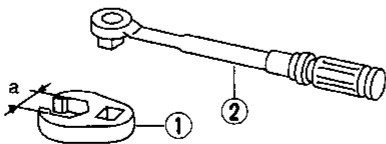
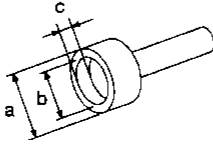
Tool name	Description	
① Flare nut crowfoot ② Torque wrench		Removing and installing each brake piping
Rear axle oil seal drift		Installing oil seal

a: 10 mm (0.39 in)

a: 74 mm (2.91 in) dia.
b: 68 mm (2.68 in) dia.
c: 10 mm (0.39 in)

REAR AXLE AND REAR SUSPENSION

2WD

SEC. 380•430•431

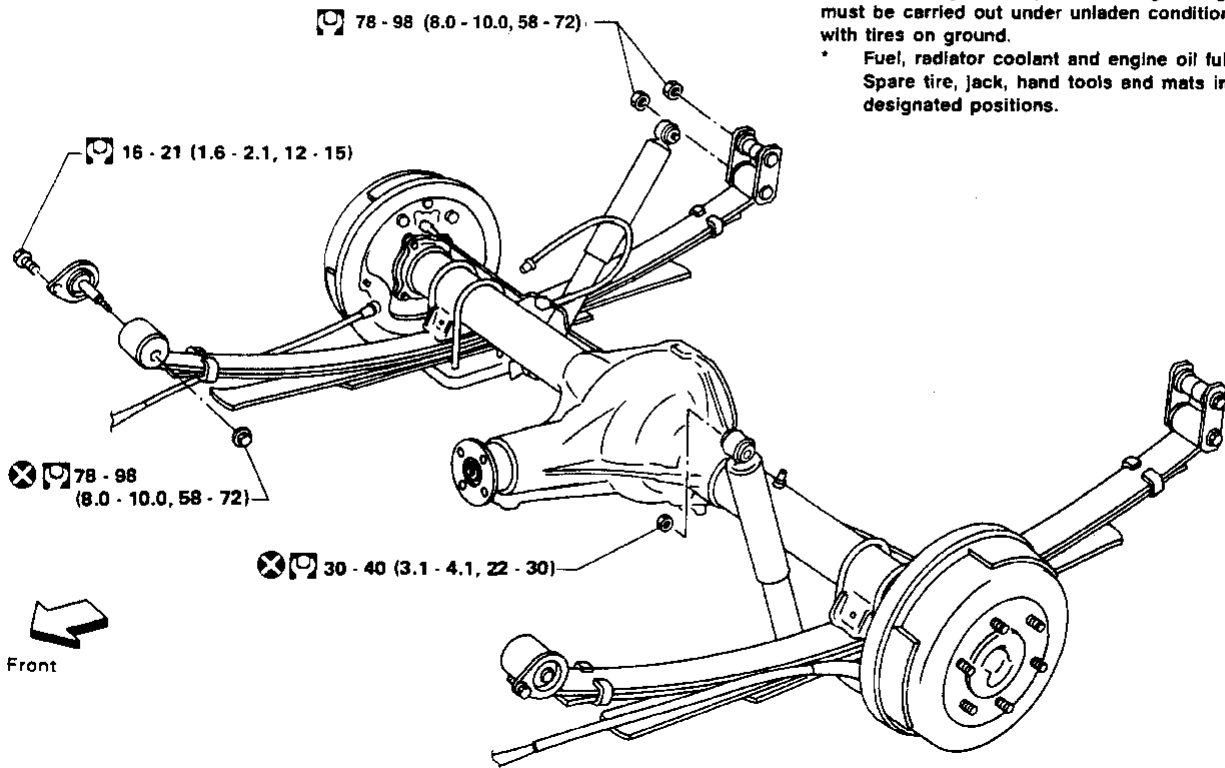

When installing rubber parts, final tightening must be carried out under unladen condition* with tires on ground.

* Fuel, radiator coolant and engine oil full. Spare tire, jack, hand tools and mats in designated positions.

: N·m (kg-m, ft-lb)

ARA068

4WD

SEC. 380•430•431

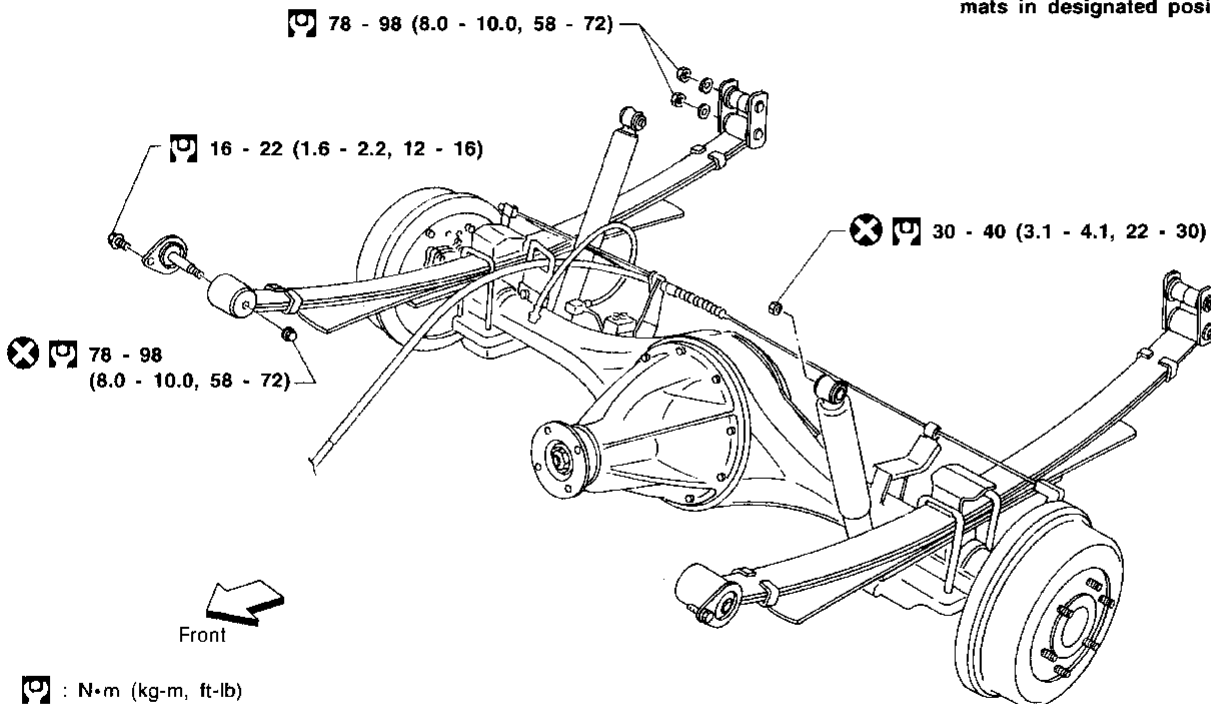

When installing each rubber part, final tightening must be carried out under unladen condition* with tires on ground.

* Fuel, radiator coolant and engine oil full. Spare tire, jack, hand tools and mats in designated positions.

: N·m (kg-m, ft-lb)

SRA751A

GI
MA
EM
LC
EC
FE
CL
MT
AT
TF
PD
FA
RA
BR
ST
RS
BT
HA
EL
IDX

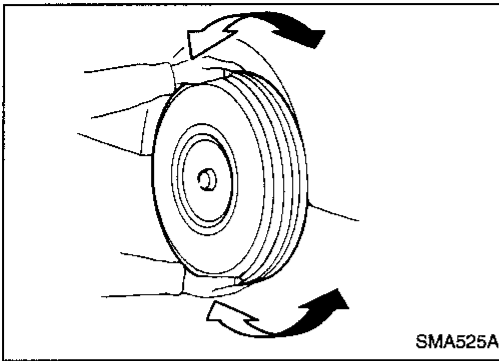

Rear Axle and Rear Suspension Parts

Check rear axle and rear suspension parts for excessive play, wear or damage.

- Shake each rear wheel to check for excessive play.

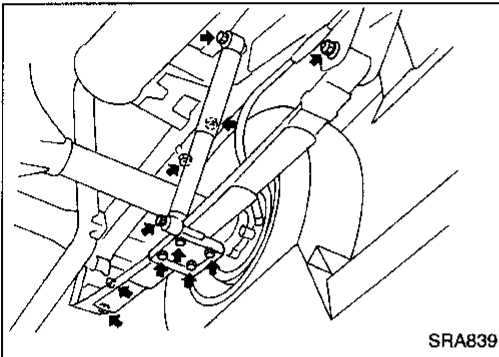

- Retighten all nuts and bolts to the specified torque.
☐: Refer to REAR SUSPENSION, RA-9.

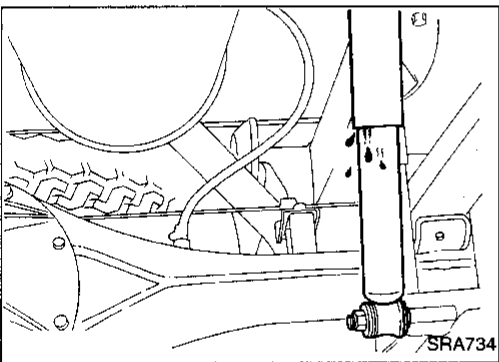

- Check shock absorber for oil leakage or other damage.
- Check shock absorber bushing for excessive wear or other damage.

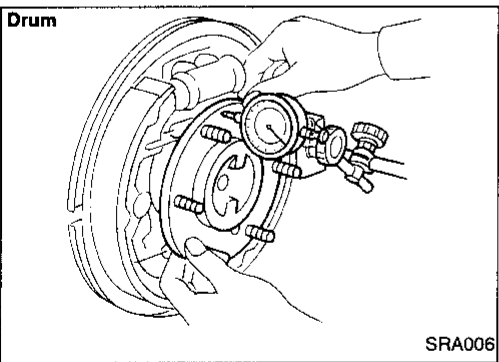

Rear Wheel Bearing

- Check that wheel bearings operate smoothly.
- Check axial end play.

Axial end play:

Refer to SDS, RA-12.

REAR AXLE

Components

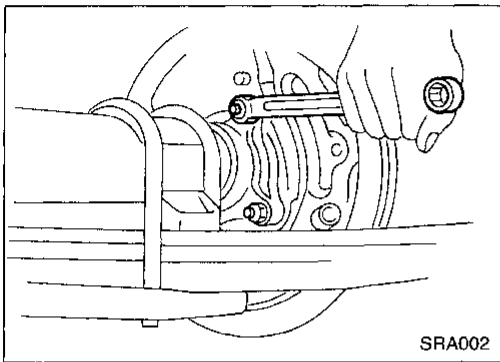
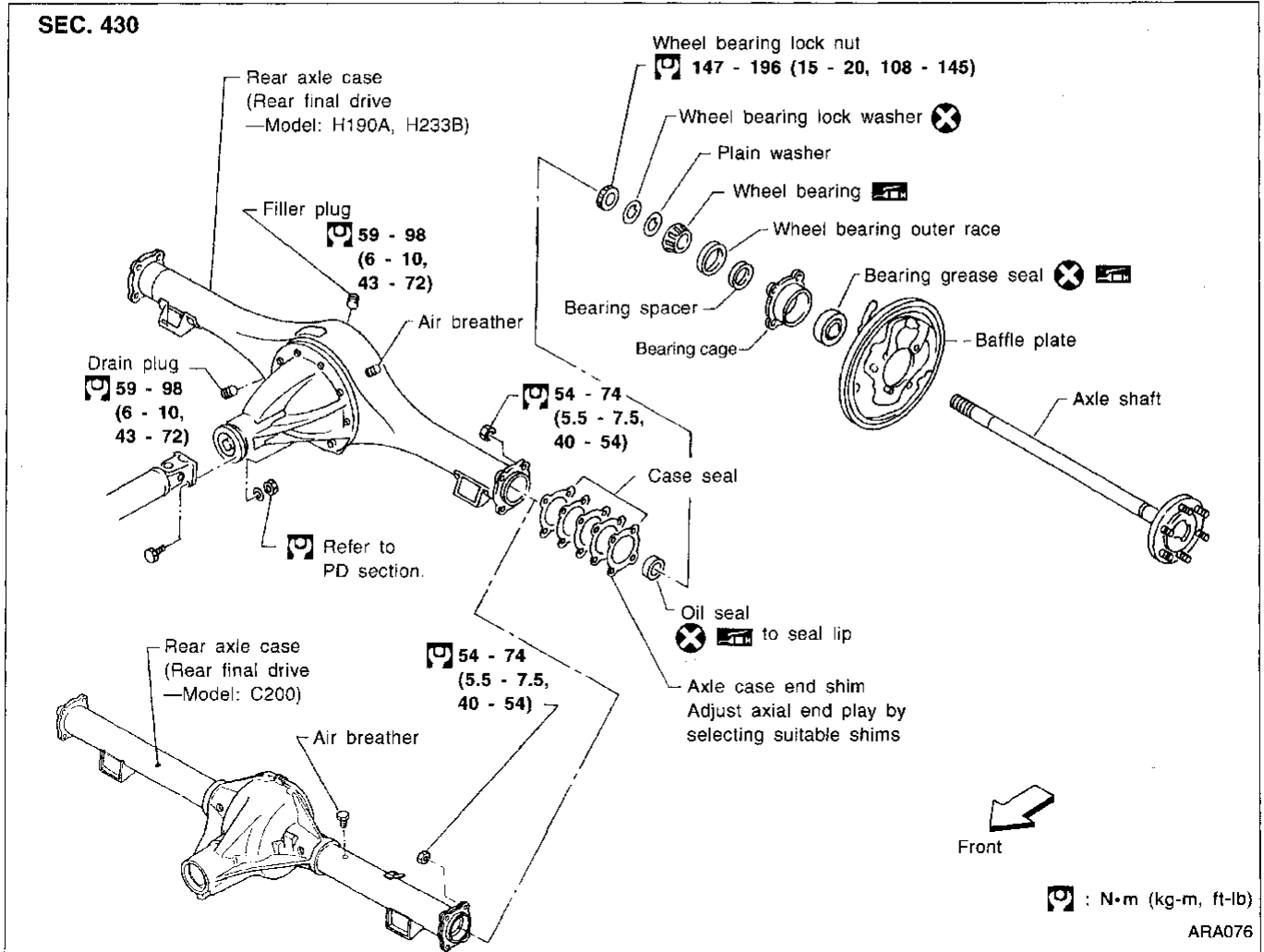

Removal

- Disconnect parking brake cable and brake tube.
- Remove nuts securing wheel bearing cage with baffle plate.

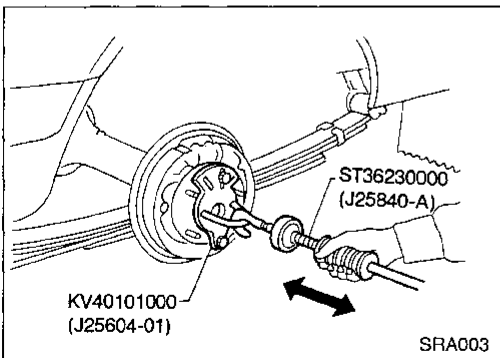

- Draw out axle shaft with Tool.
- When drawing out axle shaft, be careful not to damage oil seal.**
- Remove oil seal.
- Do not reuse oil seal once it is removed. Always install new one.**

REAR AXLE

Removal (Cont'd)

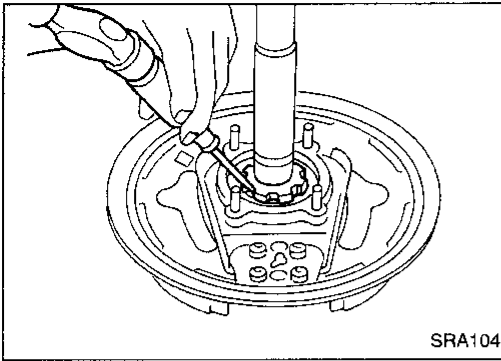

- Unbend lock washer with a screwdriver.

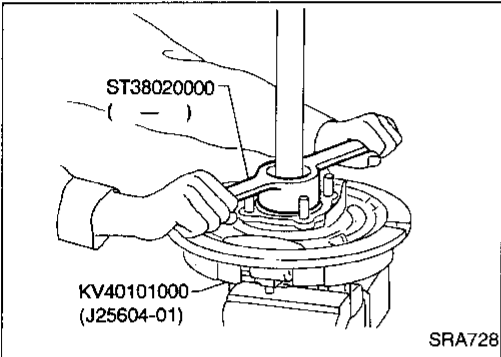

- Remove bearing lock nut with Tool.

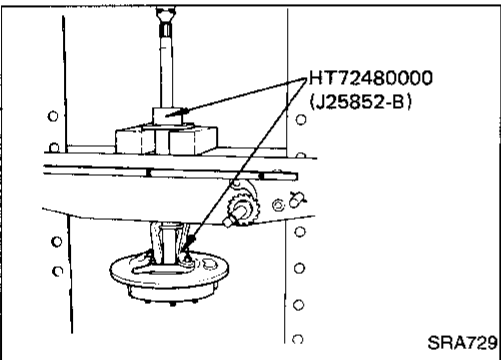

- Remove wheel bearing together with bearing cage and baffle plate from axle shaft.

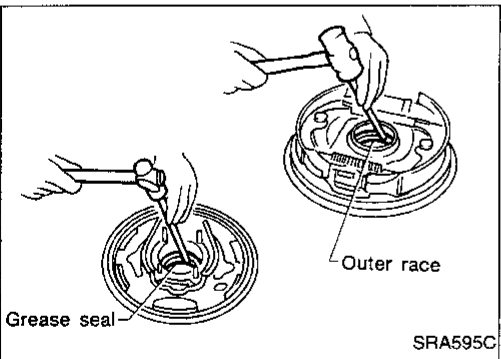

- Remove grease seal in bearing cage with suitable bar.
- Remove wheel bearing outer race with a brass drift.

REAR AXLE

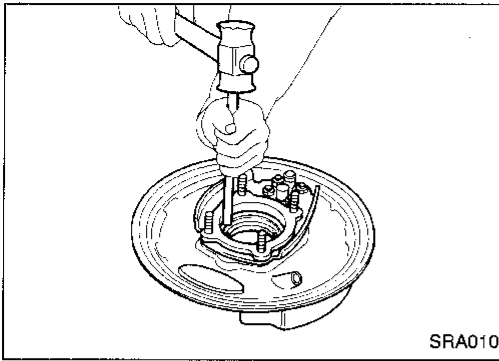

Inspection

AXLE SHAFT

- Check axle shaft for straightness, cracks, damage, wear or distortion. Replace if necessary.

WHEEL BEARING

- Make sure wheel bearing rolls freely and is free from noise, cracks, pitting or wear.

AXLE CASE

- Check axle case for yield, deformation or cracks. Replace if necessary.

Installation

- Install wheel bearing outer race with a brass drift.
- Install a new grease seal in bearing cage.

After installing new grease seal, coat sealing lip with multi-purpose grease.

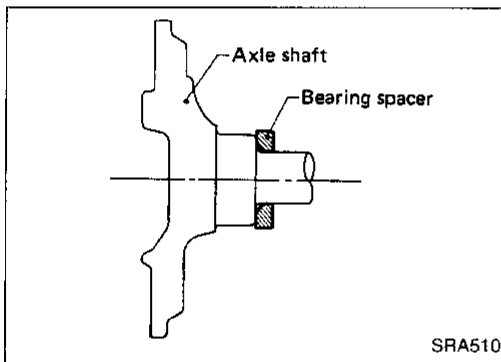

- Install bearing spacer with chamfer side facing axle shaft flange.

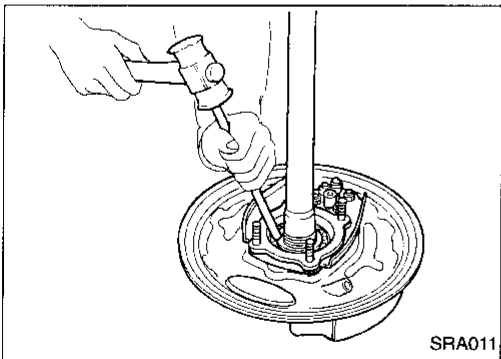

- Install wheel bearing inner race with a brass drift.
- Coat each bearing cone with multi-purpose grease.
Specified amount of grease:
8 - 12 g (0.28 - 0.42 oz)

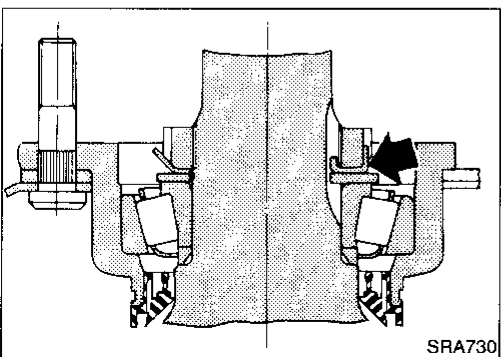

- Install plain washer and a new wheel bearing lock washer.
- Tighten wheel bearing lock nut.

Fit wheel bearing lock washer lip in wheel bearing lock nut groove correctly by tightening lock nut. Be sure to bend it up.

GI
MA
EM
LC
EC
FE
CL
MT
AT
TF
PD
FA
RA
BR
ST
RS
BT
HA
EL
IDX

REAR AXLE

Installation (Cont'd)

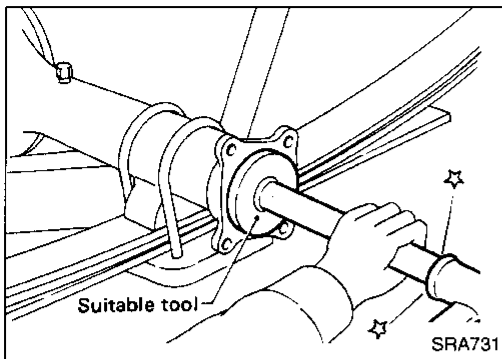

- Install a new oil seal with suitable tool.
- After installing new oil seal, coat sealing lip with multi-purpose grease.**

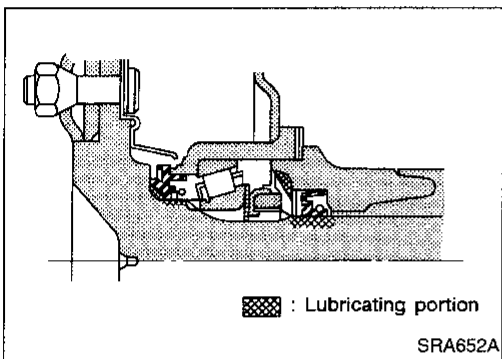

- Apply recess of axle case end with multi-purpose grease.
- Apply gear oil to the spline of axle shaft. Coat seal surface of axle shaft with multi-purpose grease (as shown left).

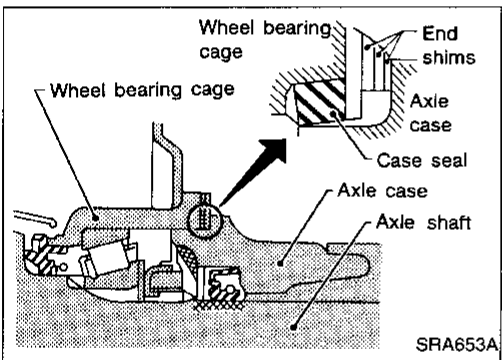

- Adjust axial end play.
- Select end shims.
 - Standard thickness: 1.5 mm (0.059 in)**
 - Axle case end shim: Refer to SDS, RA-12.**
- Do not insert end shims between case seal and bearing cage.**

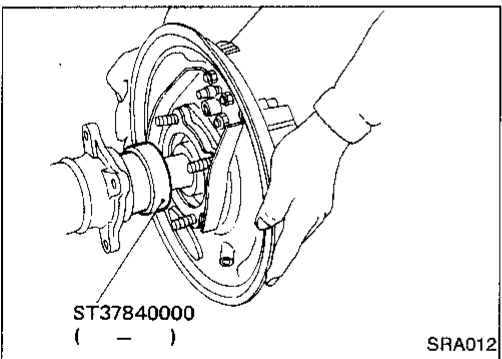

- Insert axle shaft with Tool as a guide.
- When inserting axle shaft, be careful not to damage oil seal.**
- Measure end play of axle shaft.

Axial end play:

Servicing one side axle

0.02 - 0.15 mm (0.0008 - 0.0059 in)

Servicing both side axles

On first axle (right or left)

0.30 - 0.90 mm (0.0118 - 0.0354 in)

On second axle

0.02 - 0.15 mm (0.0008 - 0.0059 in)

- If axial end play is not within the specified limit, reselect axle case end shims.

While adjusting axial end play, be careful not to damage oil seal.

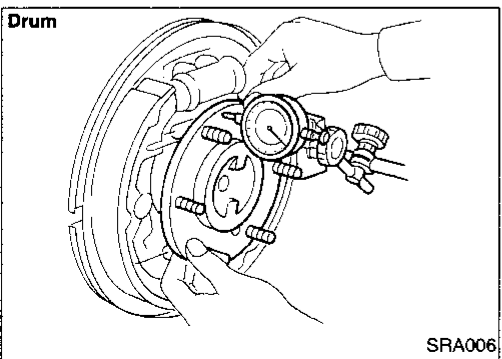

REAR SUSPENSION

2WD

GI
MA
EM
LC
EC
FE
CL
MT
AT
TF

SEC. 431

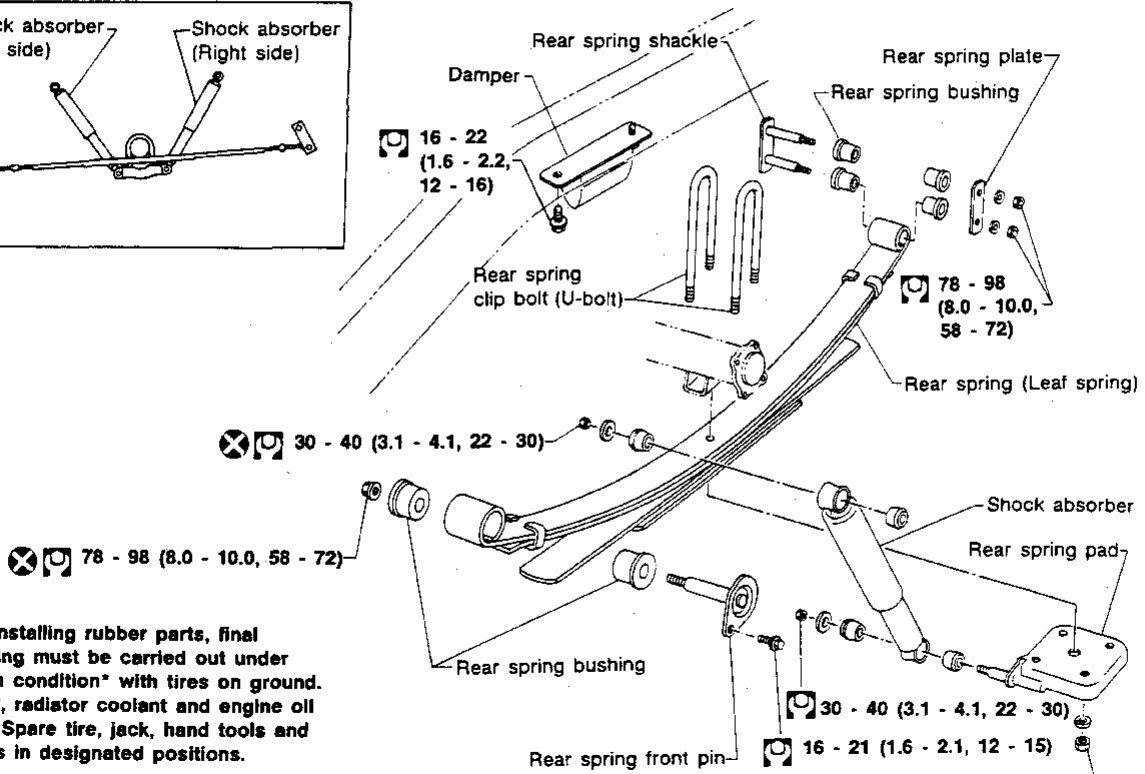
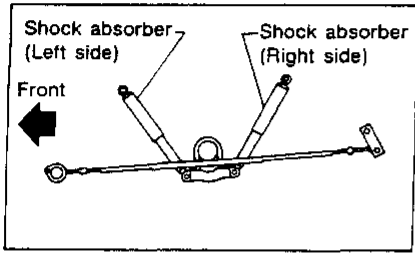

When installing rubber parts, final tightening must be carried out under unladen condition* with tires on ground.
* Fuel, radiator coolant and engine oil full. Spare tire, jack, hand tools and mats in designated positions.

: N·m (kg·m, ft·lb)

88 - 98 (9.0 - 10.0, 65 - 72) SRA593CA

4WD

PD
FA
RA
BR
ST
RS
BT
HA
EL
IDX

SEC. 431

Damper

* Make sure of front mark.

16 - 22 (1.6 - 2.2, 12 - 16)

16 - 22 (1.6 - 2.2, 12 - 16)

78 - 98 (8.0 - 10.0, 58 - 72)

16 - 22 (1.6 - 2.2, 12 - 16)

30 - 40 (3.1 - 4.1, 22 - 30)

: N·m (kg·m, ft·lb)

88 - 98 (9.0 - 10.0, 65 - 72)

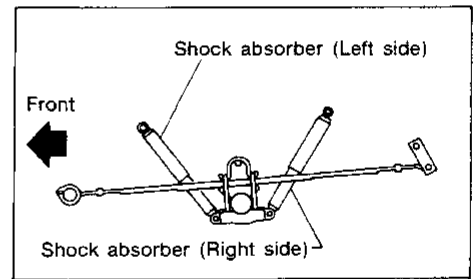
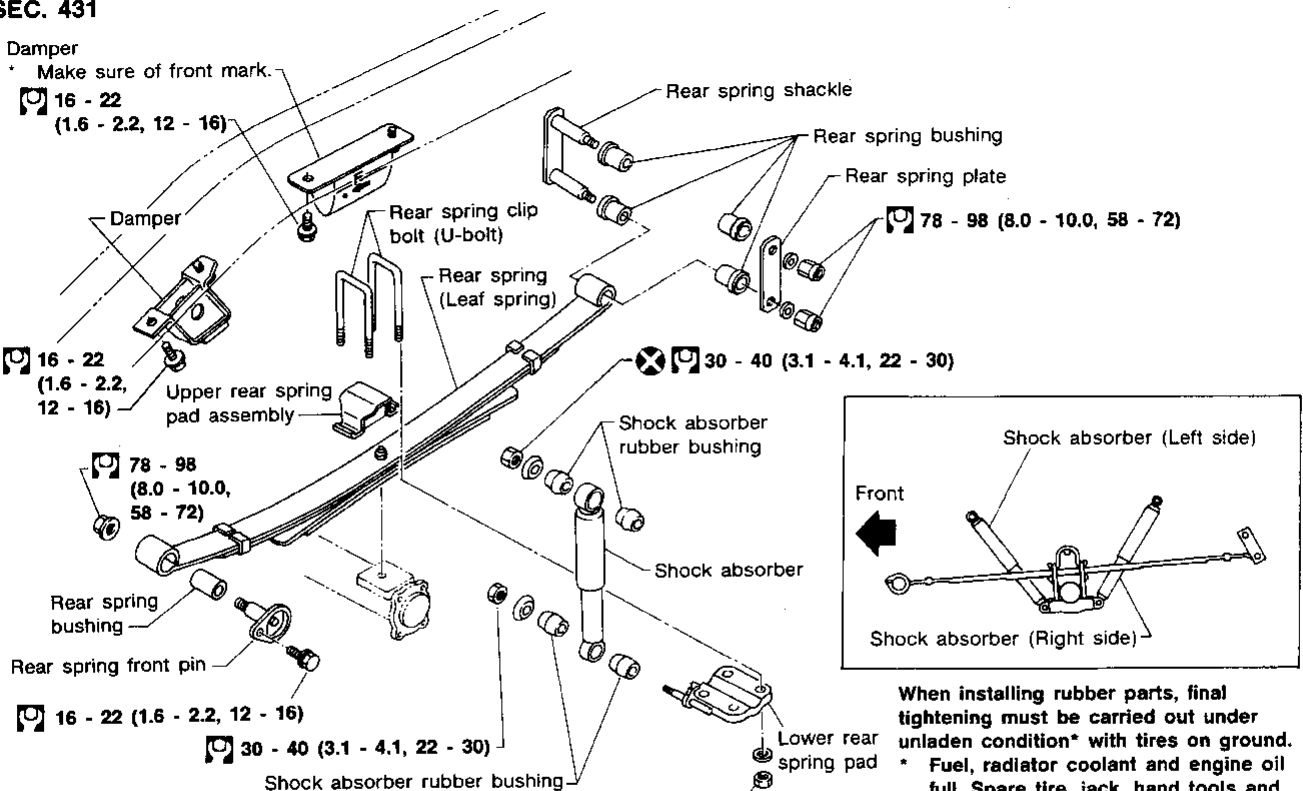

When installing rubber parts, final tightening must be carried out under unladen condition* with tires on ground.
* Fuel, radiator coolant and engine oil full. Spare tire, jack, hand tools and mats in designated positions.

SRA594CA

REAR SUSPENSION

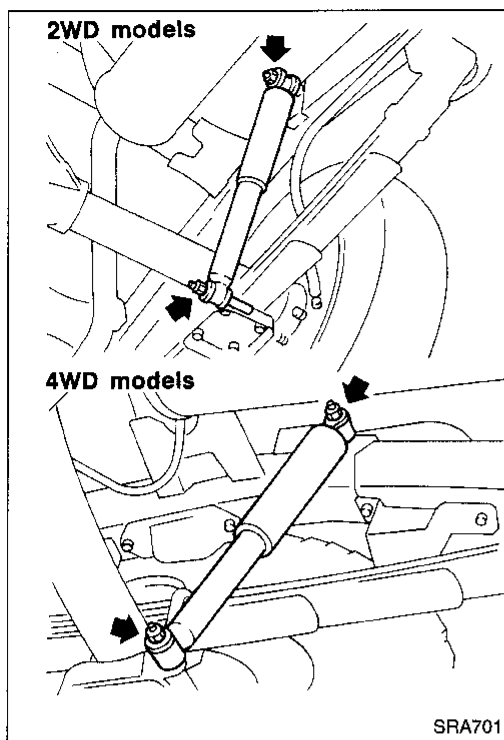

Shock Absorber

REMOVAL AND INSTALLATION

- Remove shock absorber by disconnecting upper and lower end.

INSPECTION

- If oil leakage, cracks or deformation occurs, replace shock absorber assembly.
- If rubber bushings are cracked or deformed, replace rubber bushings.

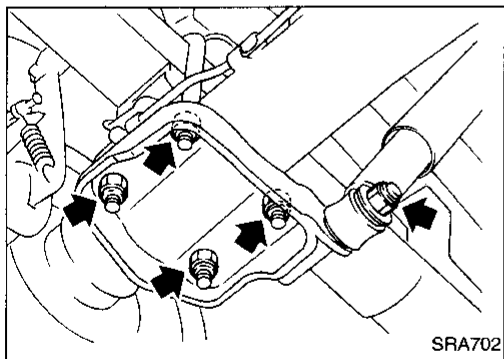

Leaf Spring

REMOVAL AND INSTALLATION

- Disconnect shock absorber lower end, and remove U-bolts.

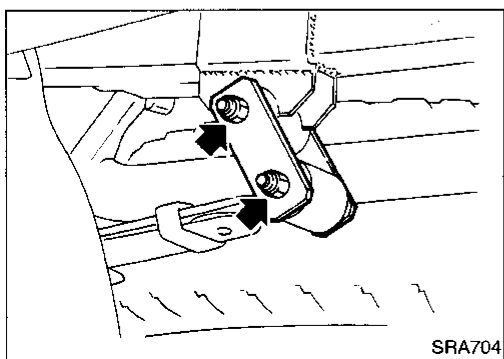

- Disconnect spring shackle.

REAR SUSPENSION

Leaf Spring (Cont'd)

- Disconnect front pin.

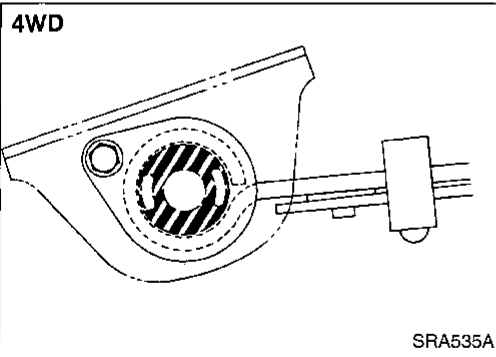
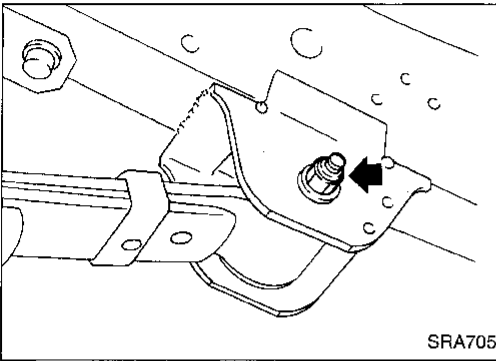

INSPECTION

- Check leaf spring for cracks. Replace if necessary.
- Check front bracket and pin, shackle, U-bolts and spring pad for wear, cracks, straightness or damaged threads. Replace if necessary.
- Check all bushings for deformation or cracks. Replace if necessary.

[4WD: Rear spring front bushing]

Make sure that front bushing is properly installed.

INSTALLATION

- Apply soapsuds to rubber bushing.
- Install spring shackle and front pin, and finger tighten the nuts.
- Install spring pad and nuts under leaf spring or axle case.
- Tighten U-bolt mounting nuts diagonally.

Tighten U-bolts so that the lengths of all U-bolts under spring pad are the same.

- Install shock absorber, and finger tighten the nuts.

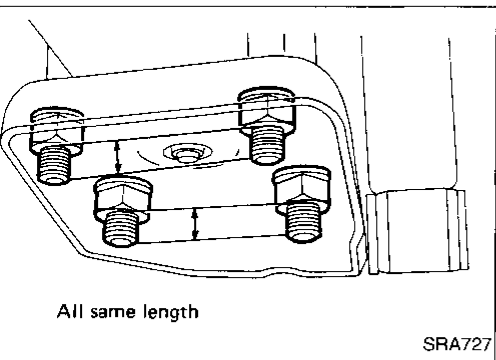

- Remove stands and bounce the vehicle to stabilize suspension. (Unladen)

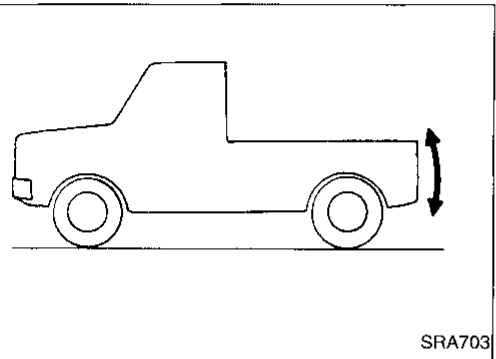

- Tighten spring shackle nuts, front pin nuts and shock absorber nuts.

When installing rubber parts, final tightening must be carried out under unladen condition* with tires on the ground.

* Fuel, radiator coolant and engine oil full. Spare tire, jack, hand tools and mats in designated positions.

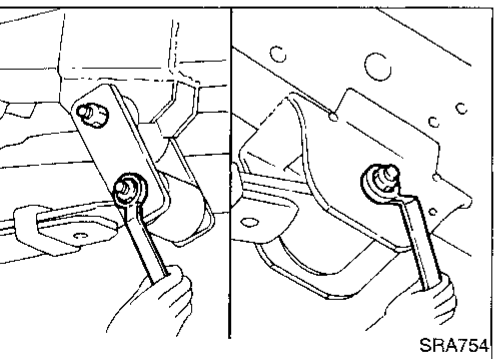

GI
MA
EM
LC
EC
FE
CL
MT
AT
TF
PD
FA
RA
BR
ST
RS
BT
HA
EL
IDX

SERVICE DATA AND SPECIFICATIONS (SDS)

General Specifications

LEAF SPRING AND SHOCK ABSORBER

Applied model	2WD				4WD
	U.S.A.	Canada			
		Regular Cab	King Cab	Option	
Leaf spring	1,200 x 60 (47.24 x 2.36)				
Spring length x width mm (in)	1,200 x 60 (47.24 x 2.36)				
Spring thickness - number of leaves mm (in)	7 (0.28) - 2 13 (0.51) - 1	7 (0.28) - 2 12 (0.47) - 2	7 (0.28) - 2 13 (0.51) - 1	7 (0.28) - 1 8 (0.31) - 1 12 (0.47) - 1 13 (0.51) - 1	
Free camber "S" mm (in)	171.0 (6.73)	183.0 (7.20)	164.5 (6.48)	171.0 (6.73)	106.0 (4.17)
Shock absorber	Non-adjustable				
Shock absorber type	Non-adjustable				
Maximum length mm (in)	508 (20.00)				528 (20.79)
Compression N (kg, lb)	157 - 275 (16 - 28, 35 - 62)				265 - 422 (27 - 43, 60 - 95)

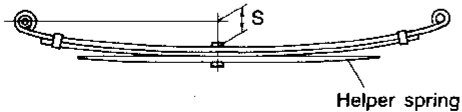

Helper spring



SRA657A

SRA658A

Inspection and Adjustment

WHEEL BEARING

Total end play mm (in)	0.02 - 0.15 (0.0008 - 0.0059)	
Available rear axle case end shims	Thickness mm (in)	Part number
	0.05 (0.0020)	43086-P0110
	0.07 (0.0028)	43087-P0110
	0.10 (0.0039)	43088-P0110
	0.15 (0.0059)	43086-B9500
	0.20 (0.0079)	43089-P0110
	0.50 (0.0197)	43090-P0110
	1.00 (0.0394)	43036-01G00