

ENGINE LUBRICATION & COOLING SYSTEM



SECTION **LC**

CONTENTS

PRECAUTIONS AND PREPARATION2	ENGINE COOLING SYSTEM7
Supplemental Restraint System (SRS) "AIR BAG".....2	Cooling Circuit7
Liquid Gasket Application Procedure2	System Check.....7
Special Service Tools3	Water Pump.....8
ENGINE LUBRICATION SYSTEM4	Thermostat.....9
Lubrication Circuit.....4	Radiator11
Oil Pressure Check.....5	Cooling Fan12
Oil Pump.....5	Overheating Cause Analysis13
	SERVICE DATA AND SPECIFICATIONS (SDS)14
	Engine Lubrication System.....14
	Engine Cooling System14

Supplemental Restraint System (SRS) "AIR BAG"

The Supplemental Restraint System "Air Bag", used along with a seat belt, helps to reduce the risk or severity of injury to the driver in a frontal collision. The Supplemental Restraint System consists of an air bag module (located in the center of the steering wheel), a diagnosis sensor unit, warning lamp, wiring harness, a crash zone sensor (4WD models) and spiral cable. Information necessary to service the system safely is included in the **RS section** of this Service Manual.

WARNING:

- To avoid rendering the SRS inoperative, which could increase the risk of personal injury or death in the event of a collision which would result in air bag inflation, all maintenance must be performed by an authorized NISSAN dealer.
- Improper maintenance, including incorrect removal and installation of the SRS, can lead to personal injury caused by unintentional activation of the system.
- Do not use electrical test equipment on any circuit related to the SRS unless instructed to in this Service Manual. SRS wiring harnesses are covered with yellow insulation either just before the harness connectors or for the complete harness, for easy identification.

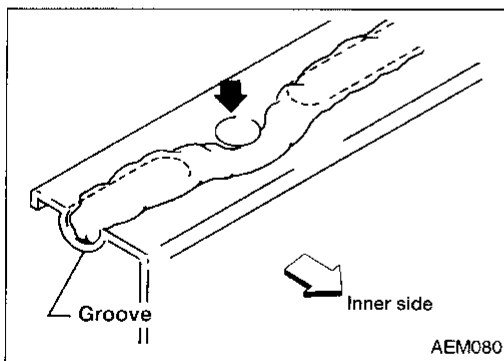
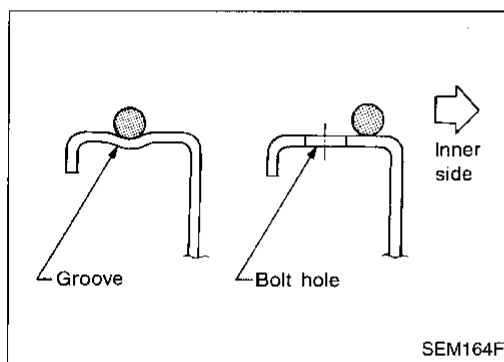

Liquid Gasket Application Procedure

- Use a scraper to remove all traces of old liquid gasket from mating surfaces and grooves. Also, completely clean any oil from these areas.
- Apply a continuous bead of liquid gasket to mating surfaces. (Use Genuine Liquid Gasket or equivalent.)
 - For oil pan, be sure liquid gasket diameter is 3.5 to 4.5 mm (0.138 to 0.177 in).
 - For areas except oil pan, be sure liquid gasket diameter is 2.0 to 3.0 mm (0.079 to 0.118 in).
- Apply liquid gasket around the inner side of bolt holes (unless otherwise specified).
- Assembly should be done within 5 minutes after coating.
- Wait at least 30 minutes before refilling engine oil and engine coolant.

PRECAUTIONS AND PREPARATION

Special Service Tools

The actual shapes of Kent-Moore tools may differ from those of special service tools illustrated here.

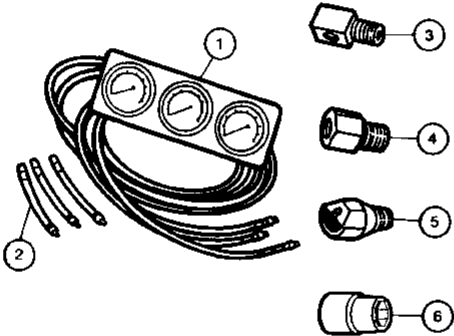
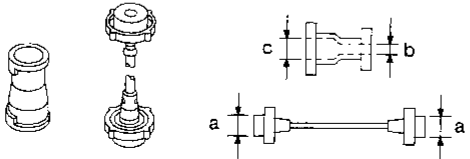
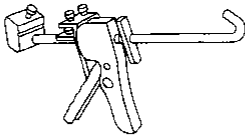
Tool number (Kent-Moore No.) Tool name	Description
(J34301-C) Oil pressure gauge set ① (J34301-1) Oil pressure gauge ② (J34301-2) Hoses ③ (J34298) Adapter ④ (J34282-1) Adapter ⑤ (790-301-1230-A) 60° adapter ⑥ (J34301-15) Square socket	 <p style="text-align: right;">Measuring oil pressure</p> <p style="text-align: right;">Maximum measuring range: 1,379 kPa (14 kg/cm², 200 psi)</p> <p>AAT546</p>
EG17650301 (J33984-A) Radiator cap tester adapter	 <p style="text-align: right;">Adapting radiator cap tester to radiator filler neck</p> <p style="text-align: right;">a: 28 (1.10) dia. b: 31.4 (1.236) dia. c: 41.3 (1.626) dia. Unit: mm (in)</p> <p>NT564</p>
WS39930000 (—) Tube presser	 <p style="text-align: right;">Pressing the tube of liquid gasket</p> <p>NT052</p>

GI

MA

EM

LC

EC

FE

CL

MT

AT

TF

PD

FA

RA

BR

ST

RS

BT

HA

EL

IDX

Lubrication Circuit

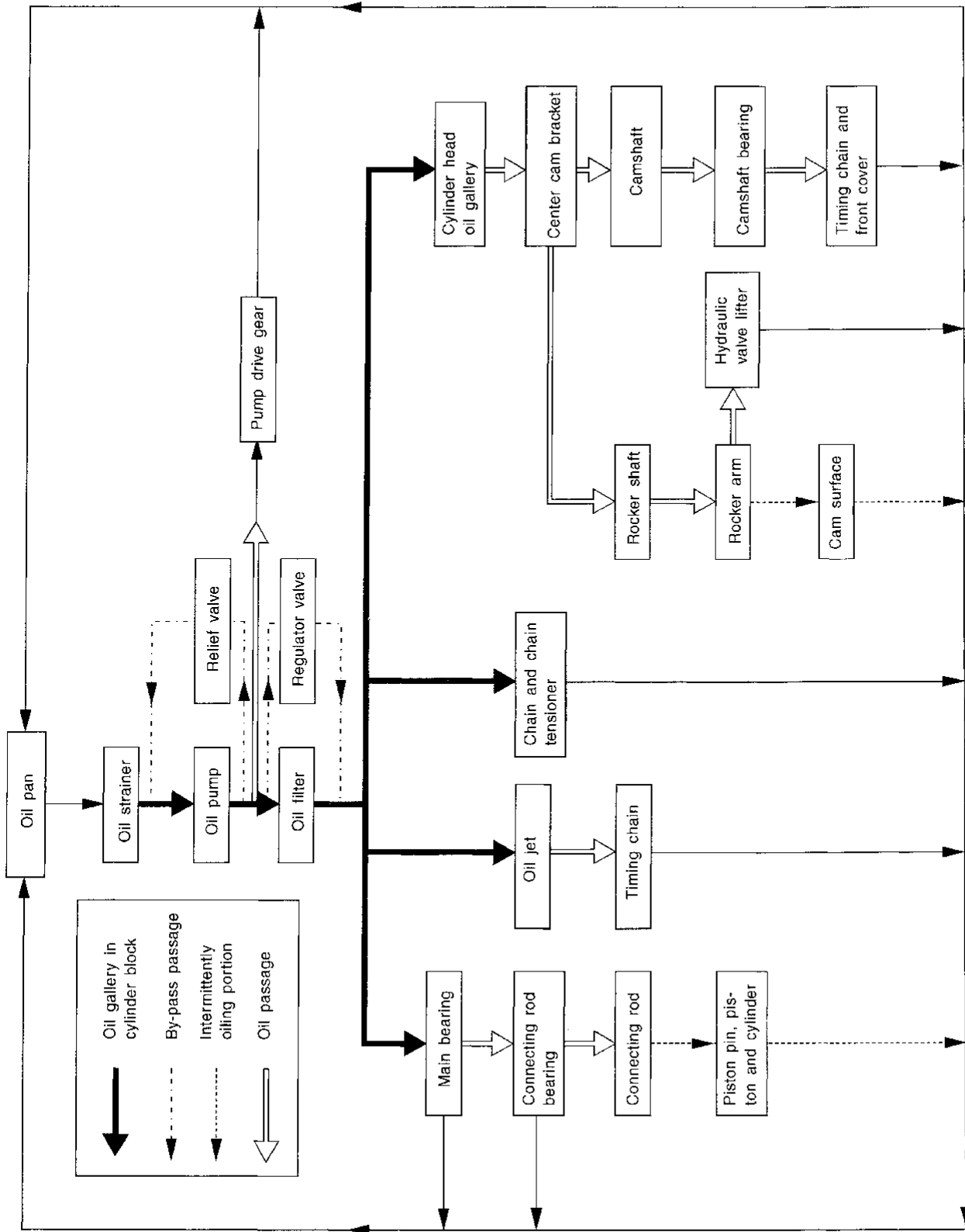

ENGINE LUBRICATION SYSTEM

GI

MA

EM

LC

EC

FE

CL

MT

AT

TF

PD

FA

RA

BR

ST

RS

BT

HA

EL

IDX

Oil Pressure Check

WARNING:

- Be careful not to burn yourself, as the engine and oil may be hot.
- For M/T models, put gearshift lever in Neutral "N" position. For A/T models, put selector lever in Park "P" position.

1. Check oil level.
2. Remove oil pressure switch.
3. Install pressure gauge.
4. Start engine and warm it up to normal operating temperature.
5. Check oil pressure with engine running under no-load.

Engine speed rpm	Approximate discharge pressure kPa (kg/cm ² , psi)
Idle speed	More than 78 (0.8, 11)
3,000	412 - 481 (4.2 - 4.9, 60 - 70)

- If difference is extreme, check oil passage and oil pump for oil leaks.

6. Install oil pressure switch with sealant.

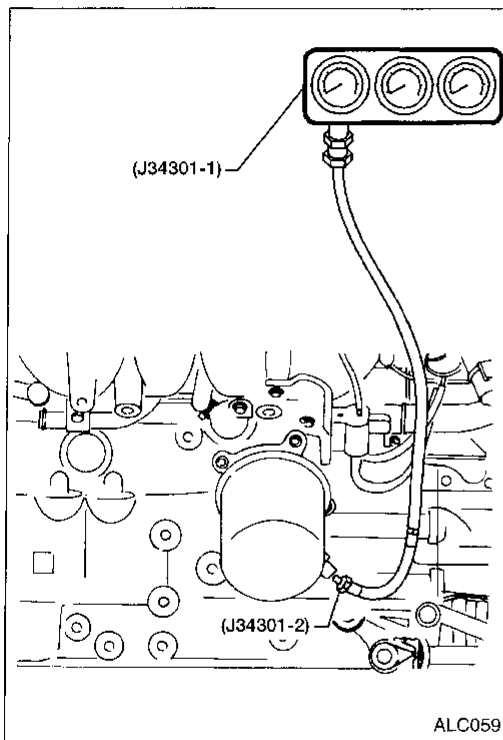

ALC059

Oil Pump

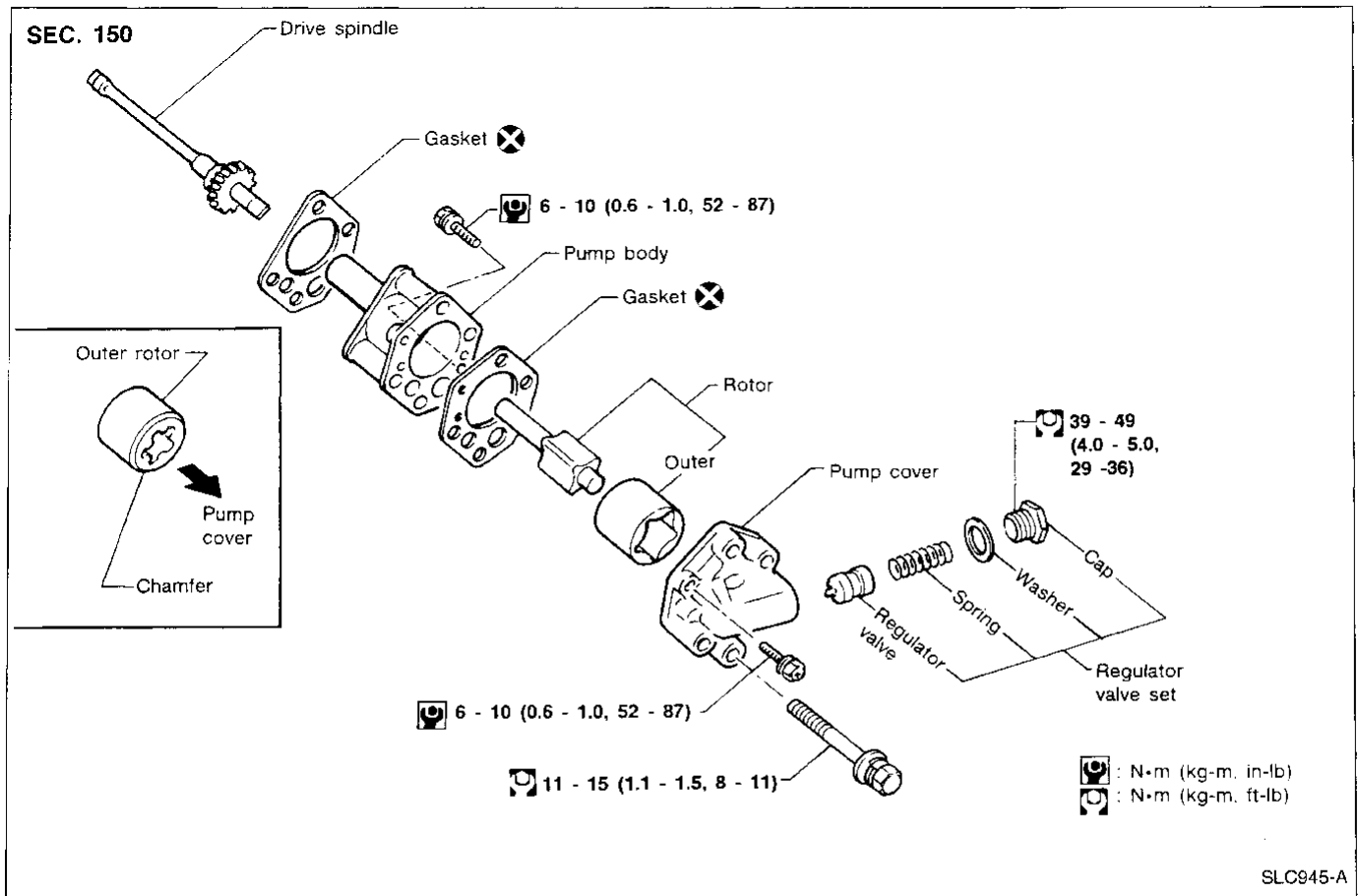

ENGINE LUBRICATION SYSTEM

Oil Pump (Cont'd)

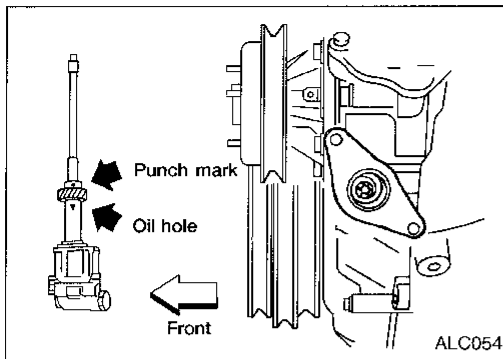

- Always replace with new oil seal and gasket.
- When removing oil pump, turn crankshaft so that No. 1 piston is at TDC on its compression stroke.
- When installing oil pump, apply engine oil to gears, then align punchmark on drive spindle and oil hole on oil pump.

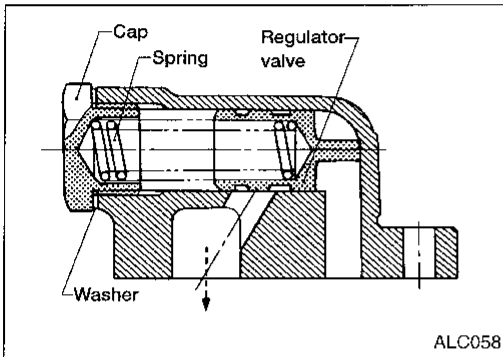

REGULATOR VALVE INSPECTION

1. Visually inspect components for wear and damage.
 2. Check oil pressure regulator valve sliding surface and valve spring.
 3. Coat regulator valve with engine oil. Check that it falls smoothly into the valve hole by its own weight.
- Replace regulator valve set or oil pump assembly if damaged.

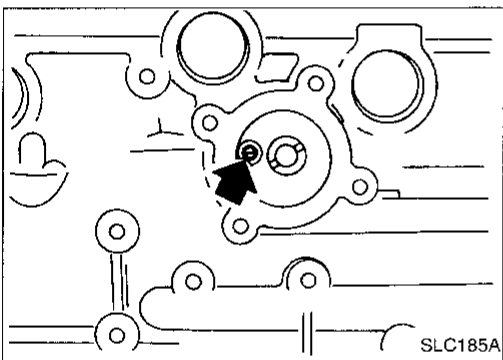

OIL PRESSURE RELIEF VALVE INSPECTION

Inspect oil pressure relief valve for movement, cracks and breaks by pushing the ball. If replacement is necessary, remove valve by prying it out with a suitable tool. Install a new valve by tapping it in place.

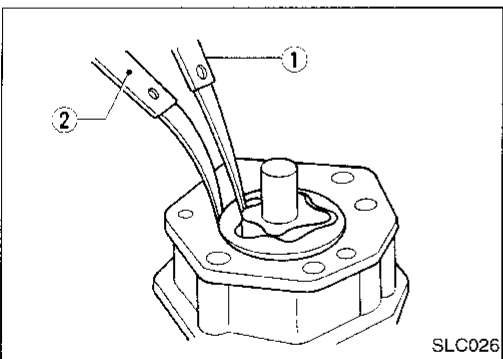

OIL PUMP INSPECTION

Use a feeler gauge to check the following clearances.

Standard clearance:

	Unit: mm (in)
Rotor tip clearance ①	Less than 0.12 (0.0047)
Outer rotor to body clearance ②	0.15 - 0.21 (0.0059 - 0.0083)
Side clearance (with gasket) ③	0.04 - 0.08 (0.0016 - 0.0031)

- If the tip clearance (①) exceeds the limit, replace gear set.
- If body to gear clearances (②, ③) exceed the limit, replace oil pump assembly.

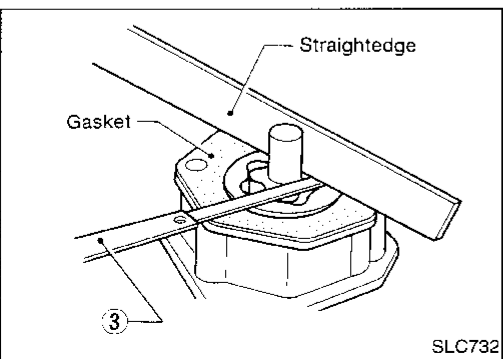

ENGINE COOLING SYSTEM

Cooling Circuit

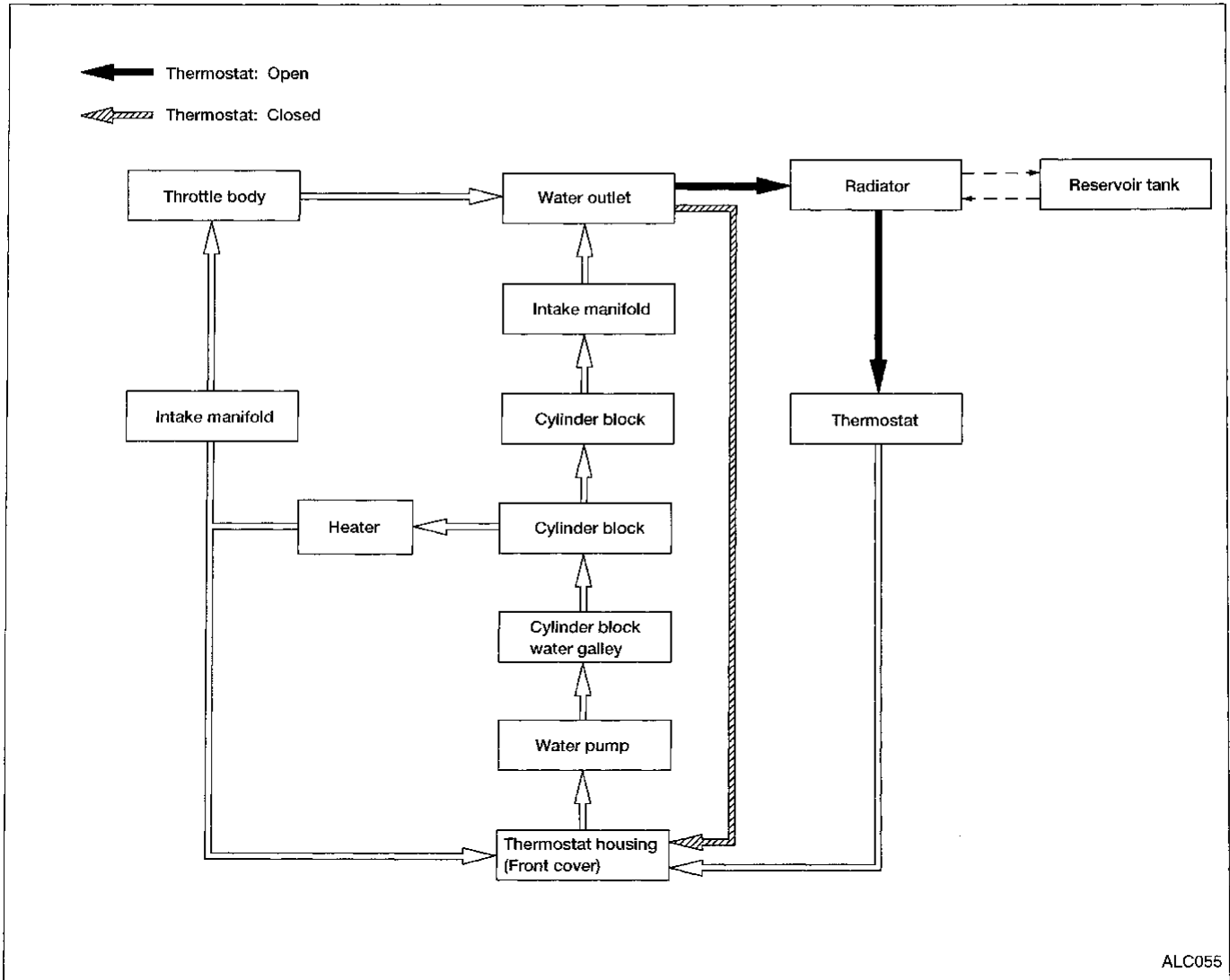

System Check

WARNING:

Never remove the radiator cap when the engine is hot. Serious burns could occur from high pressure coolant escaping from the radiator.

Wrap a thick cloth around the radiator cap. Slowly turn it a quarter turn to allow built up pressure to escape. Carefully remove the radiator cap by turning it all the way.

CHECKING COOLING SYSTEM HOSES

Check hoses for the following:

- Improper attachment
- Leaks
- Cracks
- Damage
- Chafing
- Deterioration

ENGINE COOLING SYSTEM

System Check (Cont'd)

CHECKING COOLING SYSTEM FOR LEAKS

To check for leakage, apply pressure to the cooling system with a radiator cap tester.

Testing pressure:

157 kPa (1.6 kg/cm², 23 psi)

CAUTION:

Higher pressure than specified may cause radiator damage.

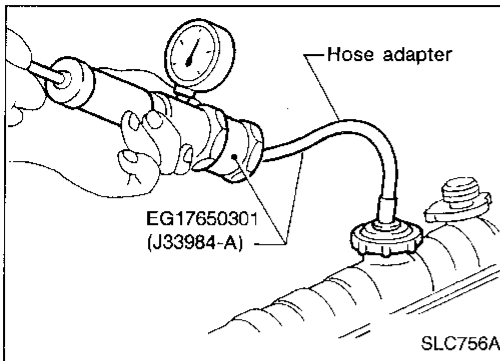

CHECKING RADIATOR CAP

To check radiator cap, apply pressure to radiator cap with a radiator cap tester.

Radiator cap relief pressure:

Standard

78 - 98 kPa (0.8 - 1.0 kg/cm², 11 - 14 psi)

Limit

59 - 98 kPa (0.6 - 1.0 kg/cm², 9 - 14 psi)

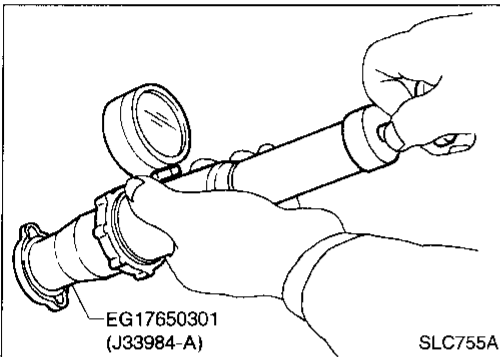

Pull the negative pressure valve to open it.
Check that it closes completely when released.

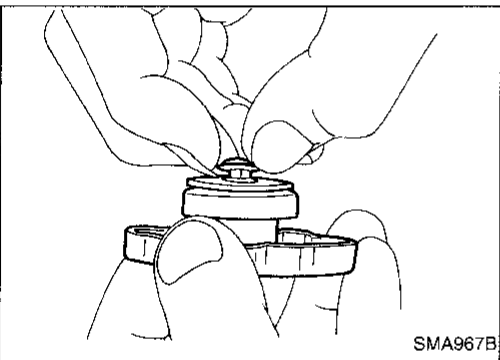

SEC. 210A

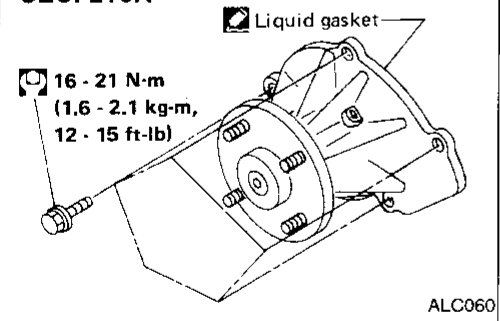

Water Pump

CAUTION:

- When removing water pump assembly, be careful not to get coolant on drive belts.
- Water pump cannot be disassembled and should be replaced as a unit.
- After installing water pump, connect hose and clamp securely, then check for leaks using radiator cap tester.

REMOVAL

1. Drain coolant from engine.
Refer to MA section ("Changing Engine Coolant", "ENGINE MAINTENANCE").
2. Remove fan coupling with fan.
3. Remove power steering pump drive belt, generator drive belt and A/C compressor drive belt.
4. Remove water pump.

ENGINE COOLING SYSTEM

Water Pump (Cont'd)

INSPECTION

- Check body assembly for rust or corrosion.
- Check for rough operation due to excessive end play.

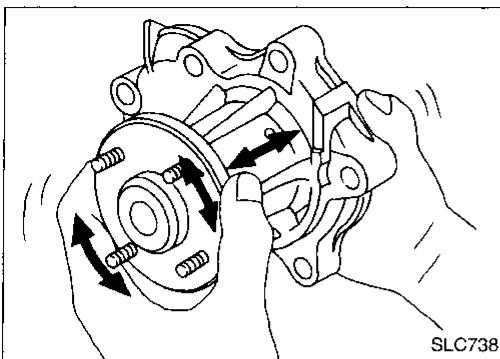

INSTALLATION

1. Use a scraper to remove liquid gasket from water pump.
 - **Also remove traces of liquid gasket from mating surface of cylinder block.**

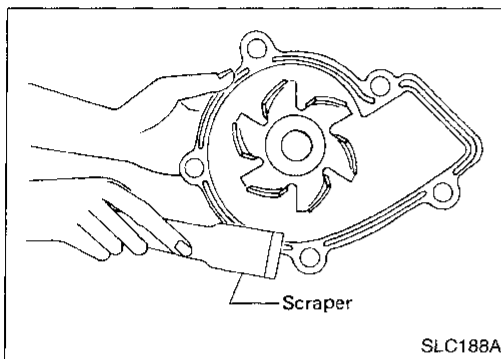

2. Apply a continuous bead of liquid gasket to mating surface of water pump.
 - **Use Genuine Liquid Gasket or equivalent.**

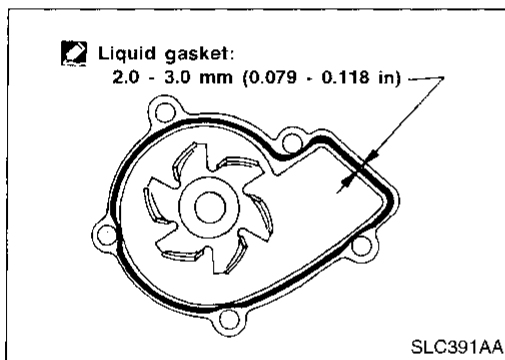

When filling radiator with coolant, refer to MA section ("Changing Engine Coolant", "ENGINE MAINTENANCE").
When installing drive belts, refer to MA section ("Checking Drive Belts").

Thermostat

- **Be careful not to spill coolant over engine compartment. Use a rag to absorb coolant.**

REMOVAL

1. Drain coolant from engine. Refer to MA section ("Changing Engine Coolant", "ENGINE MAINTENANCE").
2. Remove air cleaner and air duct assembly.
3. Remove water hose from water inlet housing.
4. Remove water inlet housing, then take out thermostat.

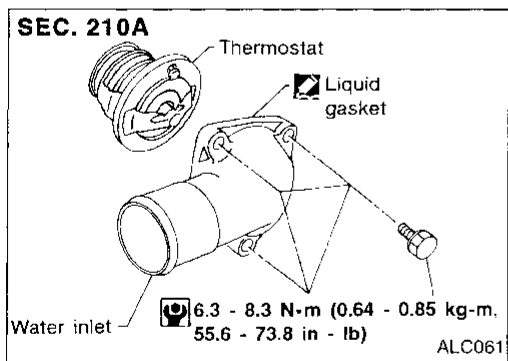

ENGINE COOLING SYSTEM

Thermostat (Cont'd)

INSPECTION

1. Check valve seating condition at normal room temperature. It should seat tightly.
2. Check valve opening temperature and valve lift.

Valve opening temperature	°C (°F)	76.5 (170)
Valve lift	mm/°C (in/°F)	More than 8/90 (0.31/194)

3. Then check if valve closes at 5°C (9°F) below valve opening temperature.

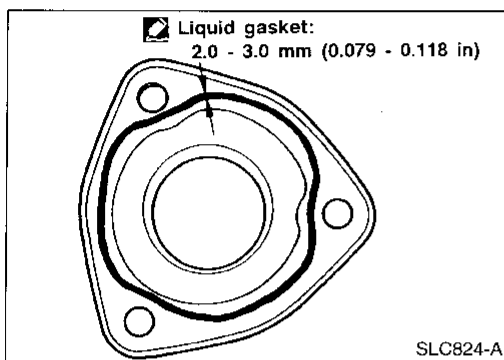
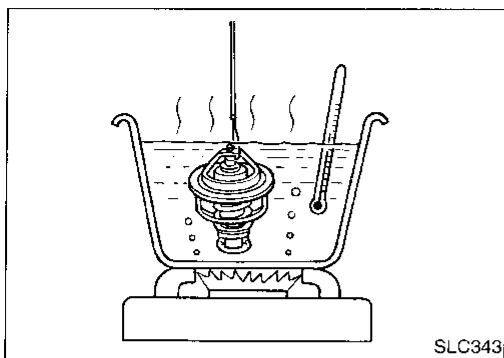

INSTALLATION

1. Use a scraper to remove old liquid gasket from water inlet.
 - Also remove traces of liquid gasket from mating surface of front cover.
2. Apply a continuous bead of liquid gasket to mating surface of water inlet.
 - Use Genuine Liquid Gasket or equivalent.

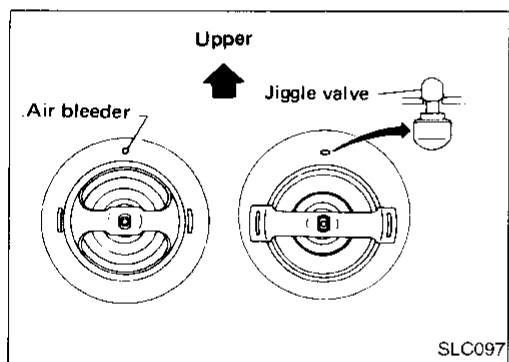

3. Install thermostat with jiggle valve or air bleeder at upper side.
4. Install water inlet housing.
5. Install water hose to water inlet housing.
6. Install air cleaner and air duct assembly.
7. Refill engine coolant. Refer to MA section ("Changing Engine Coolant", "ENGINE MAINTENANCE").
 - After installation, run engine for a few minutes, and check for leaks.

Radiator

REMOVAL AND INSTALLATION

1. Drain coolant from radiator. Refer to MA section ("Changing Engine Coolant", "ENGINE MAINTENANCE").
 2. Disconnect upper and lower radiator hoses.
 3. Remove air cleaner and air duct assembly.
 4. Remove fan coupling with fan.
 5. Remove lower radiator shroud.
 6. Remove radiator shroud.
 7. Remove A/T oil cooler hoses (A/T models only).
 8. Disconnect coolant reservoir hose.
 9. Remove radiator.
 10. After replacing radiator, install all parts in reverse order of removal.
 11. Refill engine coolant. Refer to MA section ("Changing Engine Coolant", "ENGINE MAINTENANCE").
- After installation, run engine for a few minutes, and check for leaks.

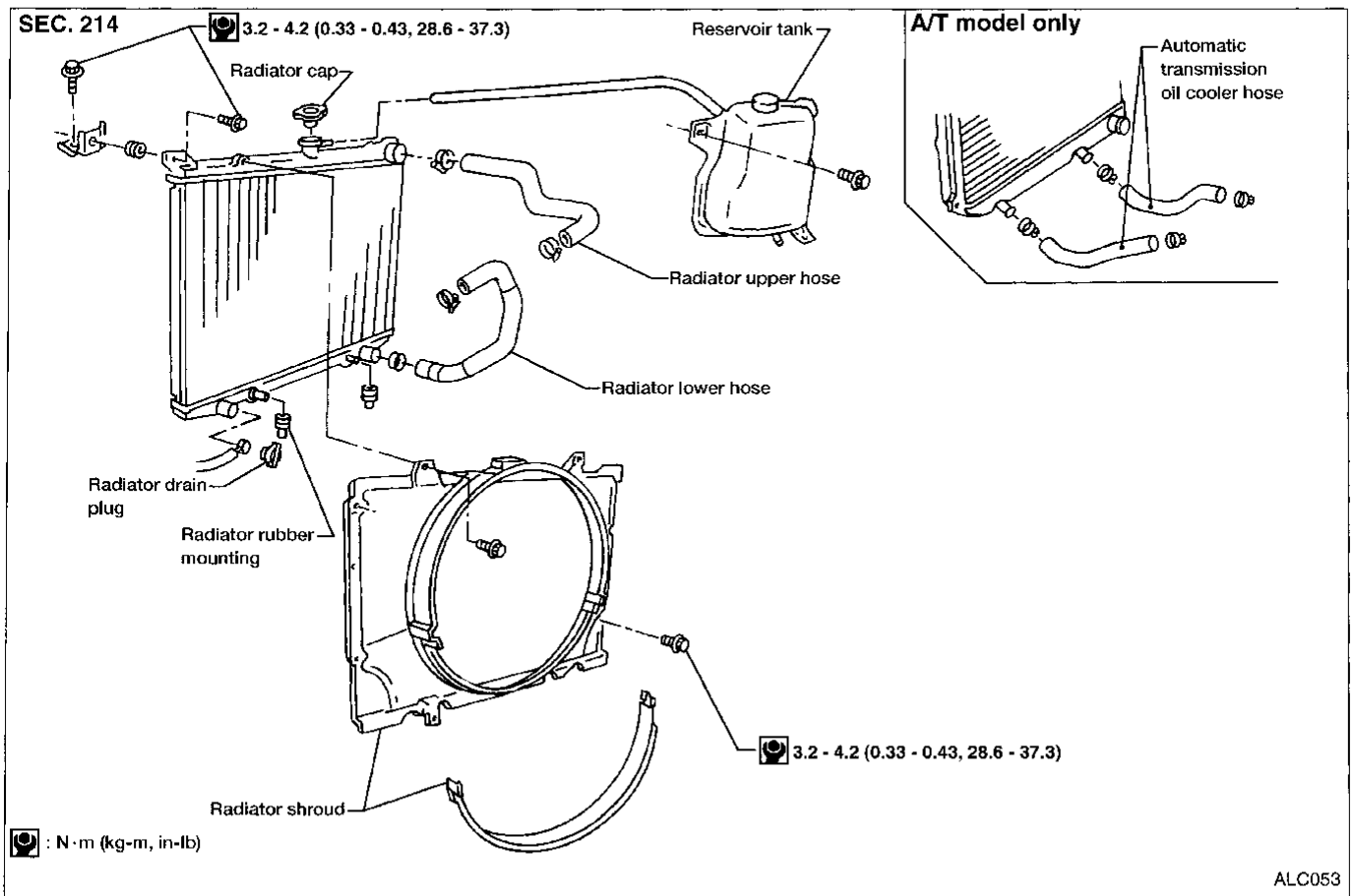

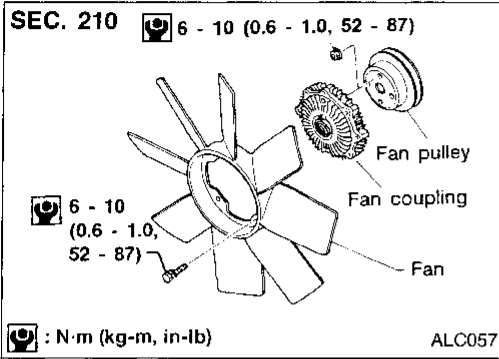

Cooling Fan DISASSEMBLY AND ASSEMBLY

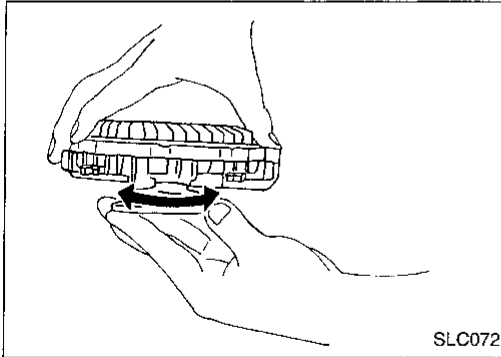

INSPECTION

Check fan coupling for rough operation, oil leakage and bent bimetal.

ENGINE COOLING SYSTEM

Overheating Cause Analysis

	Symptom		Check items	
Cooling system parts malfunction	Poor heat transfer	Water pump malfunction	Worn or loose drive belt	—
		Thermostat stuck closed	—	
		Damaged fins	Dust contamination or paper clogging	
			Mechanical damage	
	Clogged radiator cooling tube	Excess foreign material (rust, dirt, sand, etc.)		
	Reduced air flow	Cooling fan does not operate	—	—
		Fan coupling does not operate		
		High resistance to fan rotation		
		Damaged fan blades		
	Damaged radiator shroud	—	—	—
	Improper coolant mixture ratio	—	—	—
	Poor coolant quality	—	—	—
	Insufficient coolant	Coolant leaks	Cooling hose	Loose clamp
				Cracked hose
			Water pump	Poor sealing
Radiator cap			Loose	
			Poor sealing	
Radiator			O-ring for damage, deterioration or improper fitting	
		Cracked radiator tank		
		Cracked radiator core		
Reservoir tank		Cracked reservoir tank		
Overflowing reservoir tank		Exhaust gas leaks into cooling system	Cylinder head deterioration	
	Cylinder head gasket deterioration			
Except cooling system parts malfunction	—	Overload on engine	Abusive driving	High engine rpm under no load
				Driving in low gear for extended time
				Driving at extremely high speed
		Powertrain system malfunction	—	
		Installed improper size wheels and tires		
		Dragging brakes		
	Improper ignition timing	—		
	Blocked or restricted air flow	Blocked bumper	—	—
		Blocked radiator grille	Installed truck brassiere	
			Mud contamination or paper clogging	
Blocked radiator		—		
Blocked condenser		—		
Installed large fog lamp	—			

SERVICE DATA AND SPECIFICATIONS (SDS)

Engine Lubrication System

Oil pressure check

Engine speed rpm	Approximate discharge pressure kPa (kg/cm ² , psi)
Idle speed	More than 78 (0.8, 11)
3,000	412 - 481 (4.2 - 4.9, 60 - 70)

Oil pump

Unit: mm (in)

Rotor tip clearance	Less than 0.12 (0.0047)
Outer rotor to body clearance	0.15 - 0.21 (0.0059 - 0.0083)
Side clearance (with gasket)	0.04 - 0.08 (0.0016 - 0.0031)

Engine Cooling System

Thermostat

Valve opening temperature	°C (°F)	76.5 (170)
Valve lift	mm/°C (in/°F)	More than 8/90 (0.31/194)

Radiator

Unit: kPa (kg/cm², psi)

Cap relief pressure	Standard	78 - 98 (0.8 - 1.0, 11 - 14)
	Limit	59 - 98 (0.6 - 1.0, 9 - 14)
Leakage test pressure		157 (1.6, 23)