

HEATER & AIR CONDITIONER

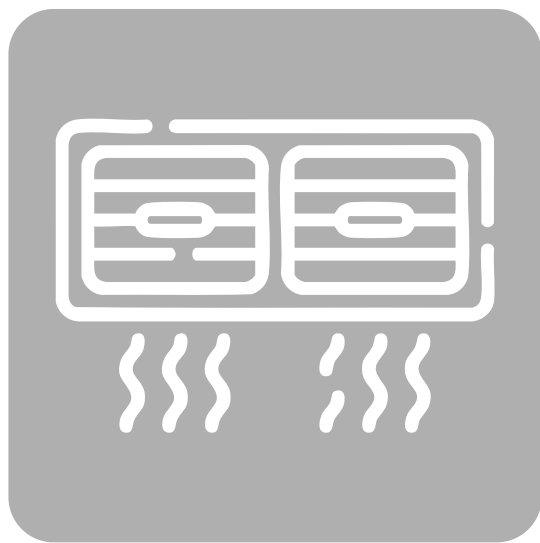

SECTION HA

CONTENTS

PRECAUTIONS AND PREPARATION2	Trouble Diagnoses for Abnormal Pressure25
Precautions for Supplemental Restraint System (SRS) "AIR BAG"2	Harness Layout.....28
Introduction3	Circuit Diagram29
Precautions for Working with R-134a.....4	Wiring Diagram –HEATER–30
General Refrigerant Precautions4	Wiring Diagram –A/C–.....31
Precautions for Refrigerant Connection5	Main Power Supply and Ground Circuit Check33
Precautions for Servicing Compressor.....6	Diagnostic Procedure 134
Special Service Tools6	Electrical Components Inspection41
R-134a Service Tools and Equipment.....7	Control Linkage Adjustment.....42
Precautions for Service Equipment.....9	SERVICE PROCEDURES44
DESCRIPTION11	Checking Refrigerant Leaks44
Refrigeration Cycle11	Refrigerant Lines47
Component Layout12	R-134a Service Procedure48
Discharge Air Flow.....13	Compressor Lubricant Quantity.....50
Control Operation14	Compressor Mounting52
TROUBLE DIAGNOSES15	Belt Tension52
How to Perform Trouble Diagnoses for Quick and Accurate Repair15	Fast Idle Control Device (FICD)52
Operational Check16	Condenser52
Symptom Chart.....18	Compressor53
Preliminary Check.....19	Compressor Clutch53
Performance Test Diagnoses22	Thermal Protector56
Performance Chart24	SERVICE DATA AND SPECIFICATIONS (SDS)57
	General Specifications.....57
	Inspection and Adjustment57

When you read wiring diagrams:

- Read GI section, "HOW TO READ WIRING DIAGRAMS".
- See EL section, "POWER SUPPLY ROUTING" for power distribution circuit.

When you perform trouble diagnoses, read GI section, "HOW TO FOLLOW FLOW CHART IN TROUBLE DIAGNOSES" and "HOW TO PERFORM EFFICIENT DIAGNOSIS FOR AN ELECTRICAL INCIDENT".

GI
MA
EM
LC
EC
FE
CL
MT
AT
TF
PD
FA
RA
BR
ST
RS
BT
HA
EL
IDX

HA

Precautions for Supplemental Restraint System (SRS) "AIR BAG"

The Supplemental Restraint System "Air Bag", used along with a seat belt, helps to reduce the risk or severity of injury to the driver in a frontal collision. The Supplemental Restraint System consists of an air bag module (located in the center of the steering wheel), a diagnosis sensor unit, warning lamp, wiring harness, a crash zone sensor (4WD models) and spiral cable. Information necessary to service the system safely is included in the **RS section** of this Service Manual.

WARNING:

- To avoid rendering the SRS inoperative, which could increase the risk of personal injury or death in the event of a collision which would result in air bag inflation, all maintenance must be performed by an authorized NISSAN dealer.
- Improper maintenance, including incorrect removal and installation of the SRS, can lead to personal injury caused by unintentional activation of the system.
- Do not use electrical test equipment on any circuit related to the SRS unless instructed to in this Service Manual. SRS wiring harnesses are covered with yellow insulation either just before the harness connectors or for the complete harness, for easy identification.

PRECAUTIONS AND PREPARATION

Introduction

To prevent the ozone layer from being destroyed, R-134a refrigerant has replaced the previously used CFC-12 (R-12).

The new and previous service tools, refrigerant, lubricant, etc. are not interchangeable due to differences in their physical properties and characteristics.

Always service the R-134a air conditioner system using the specified tools, lubricant and refrigerant, observing the following precautions:

Identification

IDENTIFICATION LABEL FOR VEHICLE

AIR CONDITIONER		NISSAN
	REFRIGERANT	COMPRESSOR LUBRICANT
TYPE [PART NO.]	R134A	NISSAN A/C SYSTEM OIL TYPE R (KLH00 - PAGR 0)
AMOUNT	0.08 ± 0.05 Kg (1.76 ± 0.11 Lbs.)	200 ml (6.8 fl. oz.)
<p>CAUTION PRECAUTION</p> <ul style="list-style-type: none"> • REFRIGERANT UNDER HIGH PRESSURE. • SYSTEM TO BE SERVICED BY QUALIFIED PERSONNEL. • IMPROPER SERVICE METHODS MAY CAUSE PERSONAL INJURY. • CONSULT SERVICE MANUAL. • THIS AIR CONDITIONER SYSTEM COMPLIES WITH SAE J-639. <p style="text-align: right;"><small>Nissan Motor Co., Ltd.</small></p>		

AHA818

PARTS IDENTIFICATION

1. Compressor label

R134a label

R134a用
USE FOR R134a

CALSONIC

TYPE DKV-14C

PART NO. _____

SERI. NO. _____

REFRIG. R-134a
OIL DH-PR
200cm³ (200cc)
(NISSAN PART No. KLH -PAGRO)

MIN. TEST PRESSURE
LOW SIDE 1.6MPa (15kgf/cm²G)
HIGH SIDE 3.0MPa (30kgf/cm²G)

MFD. ZEXEL CORPORATION
MADE IN JAPAN

2. Other component parts label

R134a label

R134a用
USE FOR R134a

Part name	Identification
1. Compressor	R134a label or Compressor label
2. Cooling unit	R134a label
3. Expansion valve	Stamp
4. Condenser	R134a label
5. Liquid tank	R134a label
6. Hose or pipe	R134a label

Base color: Light blue

3. Service valves (suction/discharge)

(Seal cap)

The service valves are specially designed for the R-134a system.
Those for the CFC-12 (R-12) system are different in size and configuration.
Refer to "SERVICE COUPLERS", "Precautions for Service Equipment", HA-10.

AHA860

PRECAUTIONS AND PREPARATION

Precautions for Working with R-134a

WARNING:

- CFC-12 (R-12) refrigerant and R-134a refrigerant are not compatible. These refrigerants must never be mixed, even in the smallest amounts. If the refrigerants are mixed, compressor malfunction is likely.
- Use only specified lubricant for the R-134a A/C system and R-134a components. If lubricant other than that specified is used, compressor malfunction is likely.
- The specified R-134a lubricant rapidly absorbs moisture from the atmosphere. The following handling precautions must be observed:
 - a: When removing refrigerant components from a vehicle, immediately cap (seal) the component to minimize the entry of moisture from the atmosphere.
 - b: When installing refrigerant components to a vehicle, do not remove the caps (unseal) until just before connecting the components. Connect all refrigerant loop components as quickly as possible to minimize the entry of moisture into the system.
 - c: Only use the specified lubricant from a sealed container. Immediately reseal containers of lubricant. Without proper sealing, lubricant will become moisture saturated and should not be used.
 - d: Avoid breathing A/C refrigerant and lubricant vapor or mist. Exposure may irritate eyes, nose and throat. Remove R-134a from the A/C system, using certified service equipment meeting requirements of SAE J2210 (R-134a recycling equipment), or J2209 (R-134a recovery equipment). If accidental system discharge occurs, ventilate work area before resuming service. Additional health and safety information may be obtained from refrigerant and lubricant manufacturers.
 - e: Do not allow lubricant to contact styrofoam parts. Damage may result.

General Refrigerant Precautions

WARNING:

- Do not release refrigerant into the air. Use approved recovery/recycling equipment to capture the refrigerant every time an air conditioner system is discharged.
- Always wear eye and hand protection (goggles and gloves) when working with any refrigerant or air conditioner system.
- Do not store or heat refrigerant containers above 52°C (125°F).
- Do not heat a refrigerant container with an open flame; if container warming is required, place the bottom of the container in a warm pail of water.
- Do not intentionally drop, puncture, or incinerate refrigerant containers.
- Keep refrigerant away from open flames: poisonous gas will be produced if refrigerant burns.
- Refrigerant will displace oxygen, therefore be certain to work in well ventilated areas to prevent suffocation.
- Do not introduce compressed air into any refrigerant container or refrigerant component.

PRECAUTIONS AND PREPARATION

Precautions for Refrigerant Connection

WARNING:

Make sure all refrigerant is discharged into the recycling equipment and the pressure in the system is less than atmospheric pressure. Then gradually loosen the discharge side hose fitting and remove it.

CAUTION:

When replacing or cleaning refrigerant cycle components, observe the following.

- Do not leave compressor on its side or upside down for more than 10 minutes. Compressor lubricant will enter low pressure chamber.
- When connecting tubes, always use a torque wrench and a back-up wrench.
- After disconnecting tubes, immediately plug all openings to prevent entry of dirt and moisture.
- When installing an air conditioner in the vehicle, connect the pipes as the final stage of the operation. Do not remove the seal caps of pipes and other components until just before required for connection.
- Allow components stored in cool areas to warm to working area temperature before removing seal caps. This prevents condensation from forming inside A/C components.
- Thoroughly remove moisture from the refrigeration system before charging the refrigerant.
- Always replace used O-rings.
- When connecting tube, apply lubricant to portions shown in illustration. Be careful not to apply lubricant to threaded portion.

Lubricant name: Nissan A/C System Oil Type R

Part number: KLH00-PAGR0

- O-ring must be closely attached to inflated portion of tube.
- After inserting tube into union until O-ring is no longer visible, tighten nut to specified torque.
- After connecting line, conduct leak test and make sure that there is no leakage. When the gas leaking point is found, disconnect that line and replace the O-ring. Then tighten connections of seal seat to the specified torque.

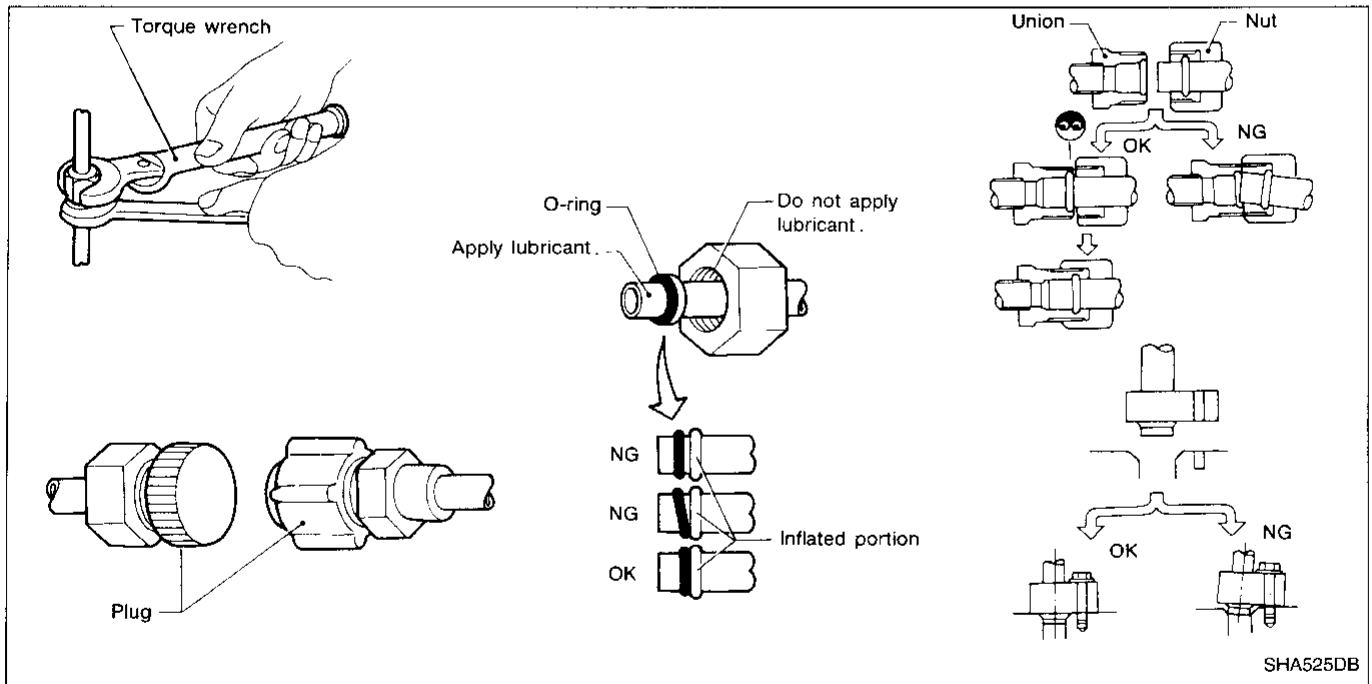

GI

MA

EM

LC

EC

FE

CL

MT

AT

TF

PD

FA

RA

BR

ST

RS

BT

HA

EL

IDX

PRECAUTIONS AND PREPARATION

Precautions for Servicing Compressor

- Plug all openings to prevent moisture and foreign matter from entering.
- Do not leave compressor on its side or upside down for more than 10 minutes. Compressor lubricant will enter low pressure chamber.
- When replacing or repairing compressor, be sure to remove lubricant from the compressor and check the lubricant quantity extracted.
- When replacing or repairing compressor, follow Lubricant — Checking and Adjusting Procedure exactly. Refer to “Compressor Lubricant Quantity”, “SERVICE PROCEDURES”, HA-50.
- Keep friction surfaces between clutch and pulley clean. If the surface is contaminated, with oil, wipe it off by using a clean waste cloth moistened with thinner.
- After compressor service operation, turn the compressor shaft by hand more than five turns in both directions. This will equally distribute lubricant inside the compressor. After the compressor is installed, let the engine idle and operate the compressor for one hour.
- After replacing the compressor magnet clutch, apply voltage to the new one and check for normal operation.

Special Service Tools

The actual shapes of Kent-Moore tools may differ from those of special service tools illustrated here.

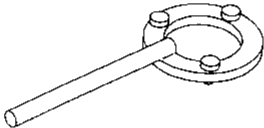
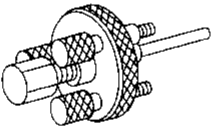
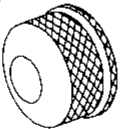
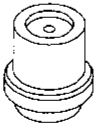
Tool number (Kent-Moore No.) Tool name	Description
KV99231260 (J-38874) Clutch disc wrench	<div style="text-align: right;">Removing shaft nut and clutch disc</div> <div style="text-align: center;">  </div> <div style="text-align: left;">NT204</div>
KV99232340 (J-38874) Clutch disc puller	<div style="text-align: right;">Removing clutch disc</div> <div style="text-align: center;">  </div> <div style="text-align: left;">NT206</div>
KV99234330 (J-39024) Pulley installer	<div style="text-align: right;">Installing pulley</div> <div style="text-align: center;">  </div> <div style="text-align: left;">NT207</div>
KV99233130 (J-39023) Center pulley puller	<div style="text-align: right;">Removing pulley</div> <div style="text-align: center;">  </div> <div style="text-align: left;">NT208</div>



PRECAUTIONS AND PREPARATION

R-134a Service Tools and Equipment

Never mix R-134a refrigerant and/or its specified lubricant with CFC-12 (R-12) refrigerant and/or its lubricant. Separate and non-interchangeable service equipment must be used for handling each type of refrigerant/lubricant.

Refrigerant container fittings, service hose fittings and service equipment fittings (equipment which handles refrigerant and/or lubricant) are different between CFC-12 (R-12) and R-134a. This is to avoid mixed use of the refrigerants/lubricant.

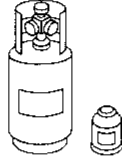

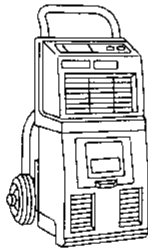
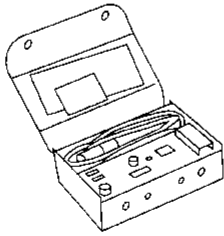
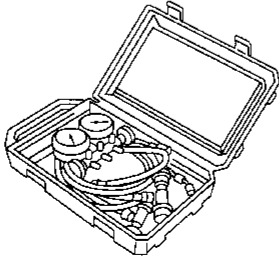
Adapters to convert from one size fitting to the other must never be used: refrigerant/lubricant contamination will occur and compressor failure will result.

Tool number (Kent-Moore No.) Tool name	Description	Note
R-134a refrigerant	 NT196	Container color: Light blue Container marking: R-134a Fitting size: Thread size ● large container 1/2"-16 ACME
KLH00-PAGR0 (—) Nissan A/C System Oil Type R	 NT197	Type: Polyalkylene glycol oil (PAG), type R Application: R-134a vane rotary compressors (Nissan only) Lubricity: 40 ml (1.4 US fl oz, 1.4 Imp fl oz)
(J-39500-NI) Recovery/Recycling equipment (ACR4)	 NT195	Function: Refrigerant Recovery and Recycling
(J-39400) Electrical leak detector	 NT198	Power supply: ● DC 12 V (Cigarette lighter)
(J-39183) Manifold gauge set (with hoses and couplers)	 NT199	Identification: ● The gauge face indicates R-134a. Fitting size: Thread size ● 1/2"-16 ACME

GI
MA
EM
LC
EC
FE
CL
MT
AT
TF
PD
FA
RA
BR
ST
RS
BT
HA
EL
IDX

PRECAUTIONS AND PREPARATION

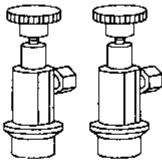
R-134a Service Tools and Equipment (Cont'd)

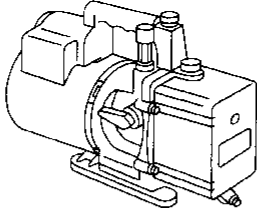
Tool number (Kent-Moore No.) Tool name	Description	Note
<p>Service hoses</p> <ul style="list-style-type: none"> ● High side hose (J-39501-72) ● Low side hose (J-39502-72) ● Utility hose (J-39476-72) 	 <p style="text-align: center;">NT201</p>	<p>Hose color:</p> <ul style="list-style-type: none"> ● Low hose: Blue with black stripe ● High hose: Red with black stripe ● Utility hose: Yellow with black stripe or green with black stripe <p>Hose fitting to gauge:</p> <ul style="list-style-type: none"> ● 1/2"-16 ACME
<p>Service couplers</p> <ul style="list-style-type: none"> ● High side coupler (J-39500-20) ● Low side coupler (J-39500-24) 	 <p style="text-align: center;">NT202</p>	<p>Hose fitting to service hose:</p> <ul style="list-style-type: none"> ● M14 x 1.5 fitting (optional) or permanently attached.
<p>(J-39650) Refrigerant weight scale</p>	 <p style="text-align: center;">NT200</p>	<p>For measuring of refrigerant</p> <p>Fitting size: Thread size</p> <ul style="list-style-type: none"> ● 1/2"-16 ACME
<p>(J-39649) Vacuum pump (Including the isolator valve)</p>	 <p style="text-align: center;">NT203</p>	<p>Capacity:</p> <ul style="list-style-type: none"> ● Air displacement: 4 CFM ● Micron rating: 20 microns ● Oil capacity: 482 g (17 oz) <p>Fitting size: Thread size</p> <ul style="list-style-type: none"> ● 1/2"-16 ACME

PRECAUTIONS AND PREPARATION

Precautions for Service Equipment

RECOVERY/RECYCLING EQUIPMENT

Follow the manufacturer's instructions for machine operation and machine maintenance. Never introduce any refrigerant other than that specified into the machine.

ELECTRONIC LEAK DETECTOR

Follow the manufacturer's instructions for tester operation and tester maintenance.

VACUUM PUMP

The lubricating oil contained inside the vacuum pump is not compatible with the specified lubricant for R-134a A/C systems. The vent side of the vacuum pump is exposed to atmospheric pressure. Therefore, if the pump is switched off after evacuation, the lubricating oil may migrate into the hose. To prevent this, isolate the pump from the hose after evacuation (vacuuming).

This migration is avoided by placing a manual shut-off valve near the hose-to-pump connection, as follows:

- Usually vacuum pumps have a manual isolator valve as part of the pump. Close this valve to isolate the service hose from the pump.
- For pumps without an isolator valve, use a hose equipped with a manual shut-off valve near the pump end. Close the valve to isolate the hose from the pump.
- If the hose has an automatic shut-off valve, disconnect the hose from the pump: as long as the hose is connected, the valve is open and lubricating oil may migrate.

Some one-way valves open when vacuum is applied and close under a no vacuum condition. Such valves may restrict the pump's ability to pull a deep vacuum and are not recommended.

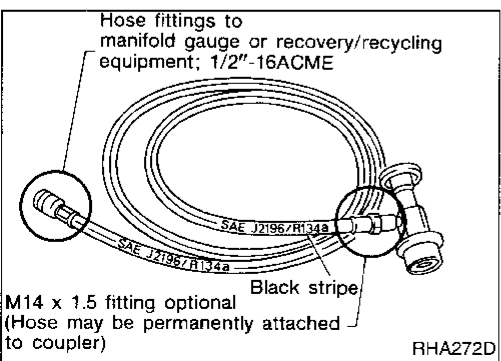
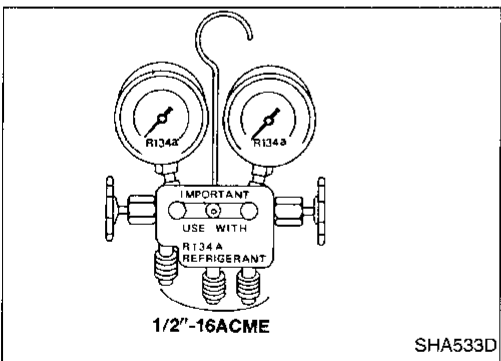
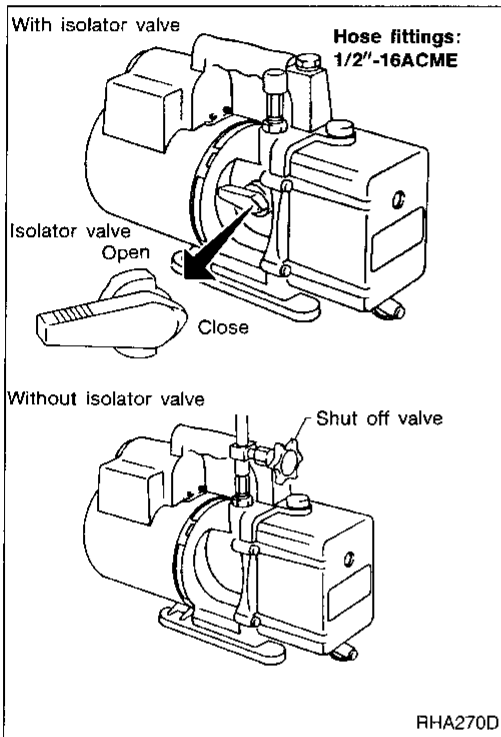

MANIFOLD GAUGE SET

Be certain the gauge set has 1/2"-16 ACME threaded connections for service hoses. Confirm the set has been used only with refrigerant R-134a along with specified lubricant.

SERVICE HOSES

Be certain that the service hoses display the markings described (colored hose with black stripe). Be certain that all hoses include a positive shut-off device (either manual or automatic) near the end of the hoses opposite the manifold gauge.

GI
MA
EM
LC
EC
FE
CL
MT
AT
TF
PD
FA
RA
BR
ST
RS
BT
HA
EL
IDX

PRECAUTIONS AND PREPARATION

Precautions for Service Equipment (Cont'd)

SERVICE COUPLERS

Never attempt to connect R-134a service couplers to an CFC-12 (R-12) A/C system. The R-134a couplers will not properly connect to the CFC-12 (R-12) system. However, if an improper connection is attempted, discharging and contamination may occur

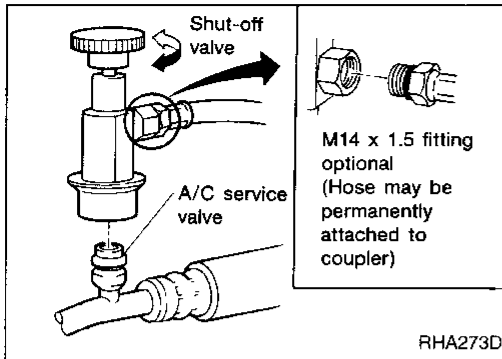

Shut-off valve rotation	A/C service valve
Clockwise	Open
Counterclockwise	Close

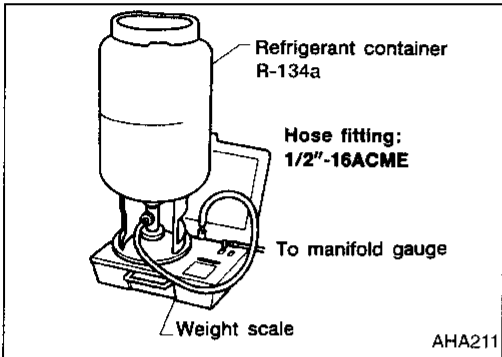

REFRIGERANT WEIGHT SCALE

When using a scale which controls refrigerant flow electronically, assure the following:

- Hose fitting size is 1/2"-16 ACME
- No refrigerant other than R-134a (along with specified lubricant) has been used with the scale.

CHARGING CYLINDER

Using a charging cylinder is not recommended. Refrigerant may be vented into the air through the cylinder's top valve when filling the cylinder.

DESCRIPTION

Refrigeration Cycle

REFRIGERANT FLOW

The refrigerant flows in the standard pattern. It flows from compressor through condenser, liquid tank, evaporator and back to compressor.

The refrigerant evaporation through the evaporator coil is controlled by an externally equalized expansion valve, located inside the evaporator case.

FREEZE PROTECTION

The compressor cycles on and off to maintain the evaporator temperature within a specified range. When the evaporator coil temperature falls below a specified point, the thermo control amplifier interrupts the compressor operation. When the evaporator coil temperature rises above the specification, the thermo control amplifier allows compressor operation.

REFRIGERANT SYSTEM PROTECTION

Dual-pressure switch

The refrigerant system is protected against excessively high or low pressure. The protection is effected by the dual-pressure switch located on the liquid tank. If the pressure rises or falls out of specifications, the switch opens to interrupt the compressor operation.

Pressure relief valve

The refrigerant system is also protected by a pressure relief valve. The valve is located on the end of high flexible hose near compressor. When refrigerant pressure in the system increases abnormally [over 3,727 kPa (38 kg/cm², 540 psi)], the relief valve's release port opens automatically. The valve then releases refrigerant into the atmosphere.

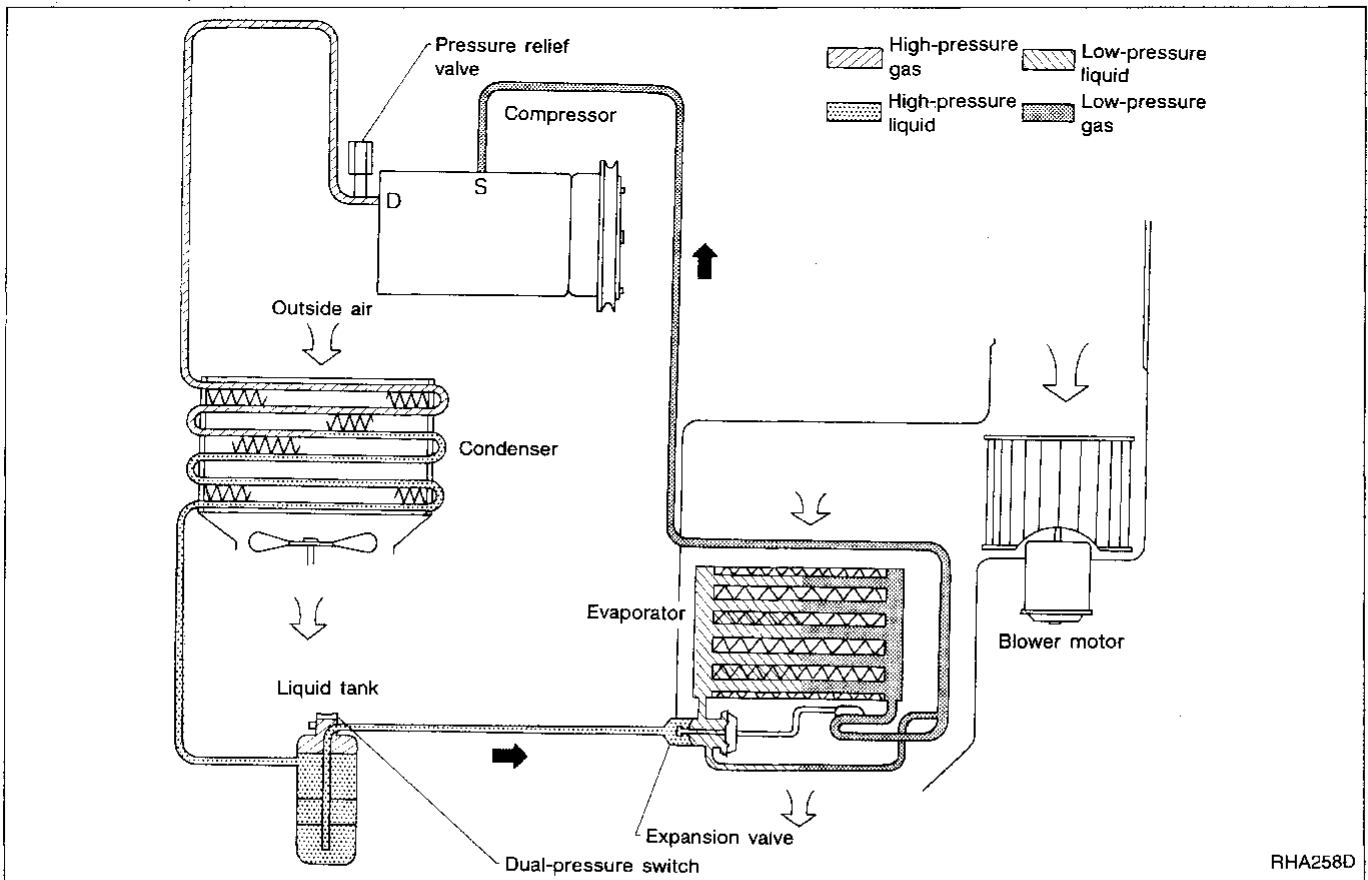

DESCRIPTION

Component Layout

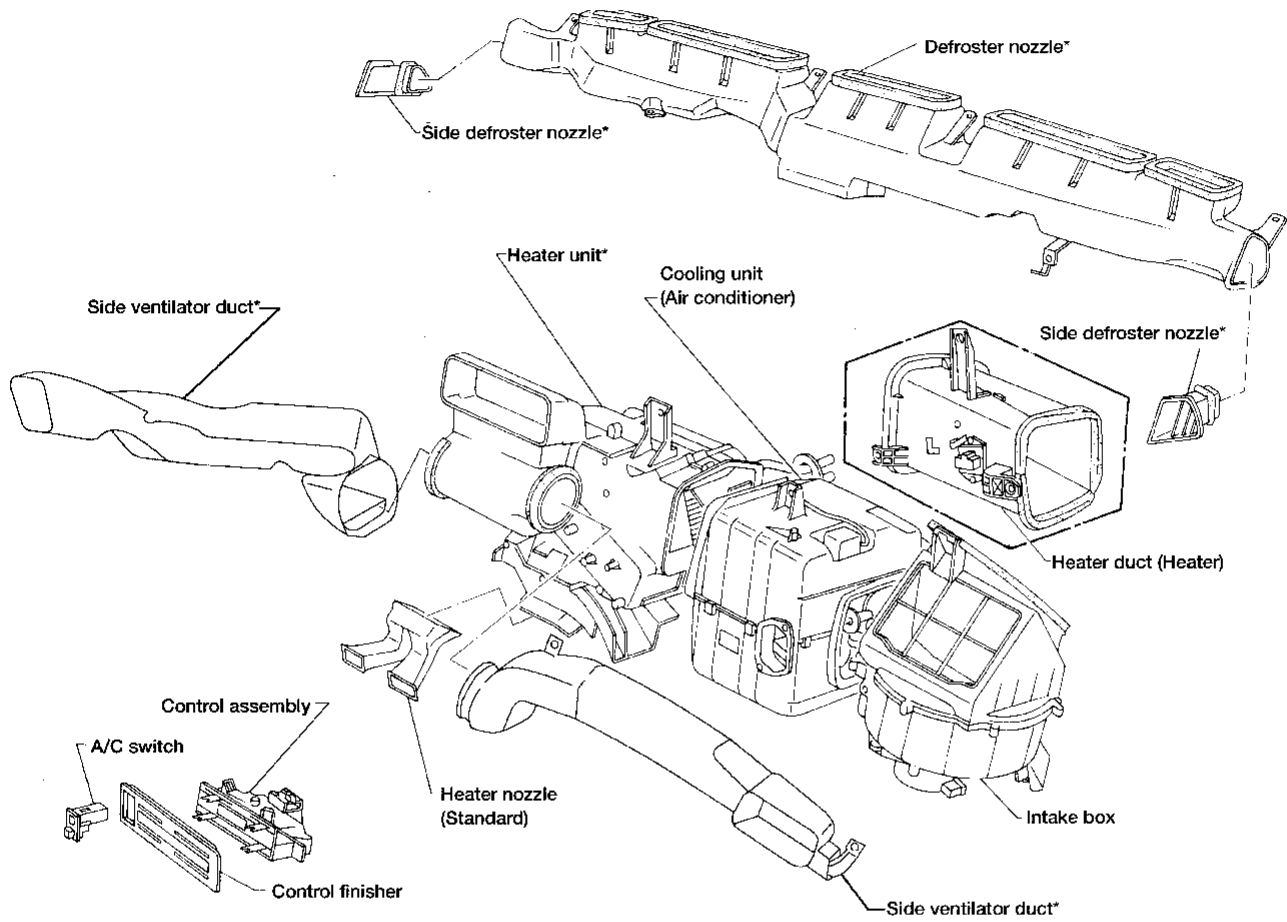

* : For removal, it is necessary to remove instrument assembly.

DESCRIPTION

Discharge Air Flow

Air outlets

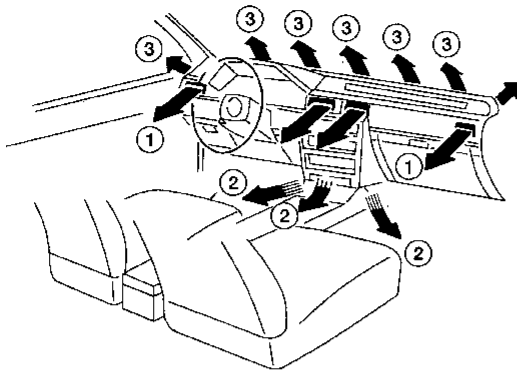

Foot

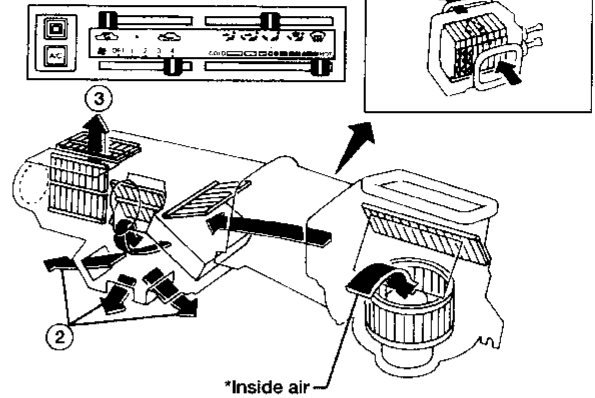

Face

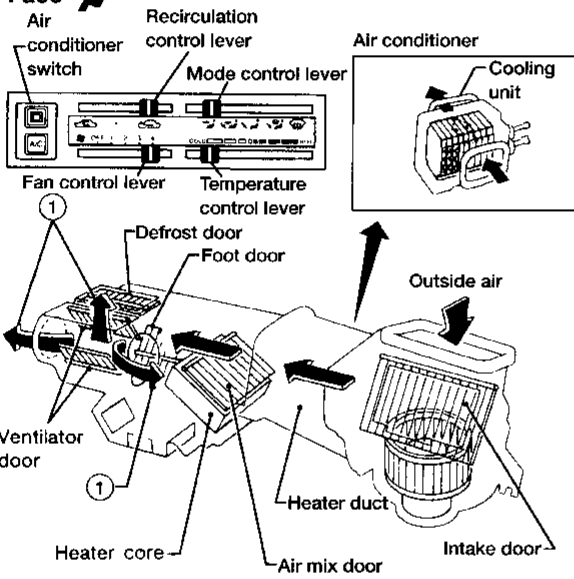

Foot and defrost

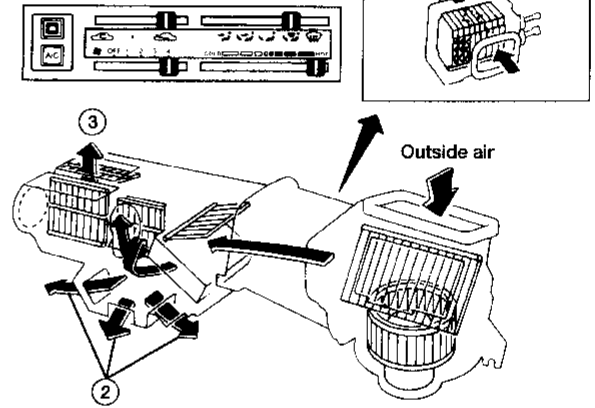

Bi-level

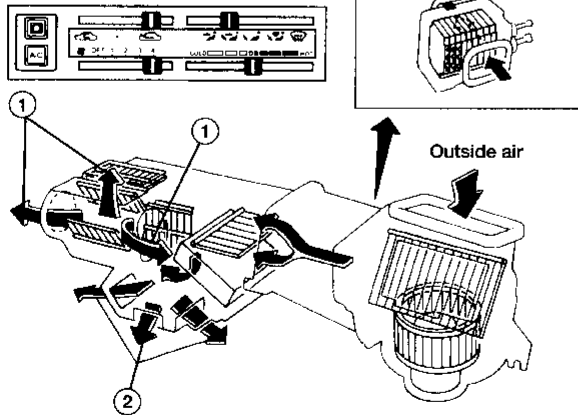

Defrost

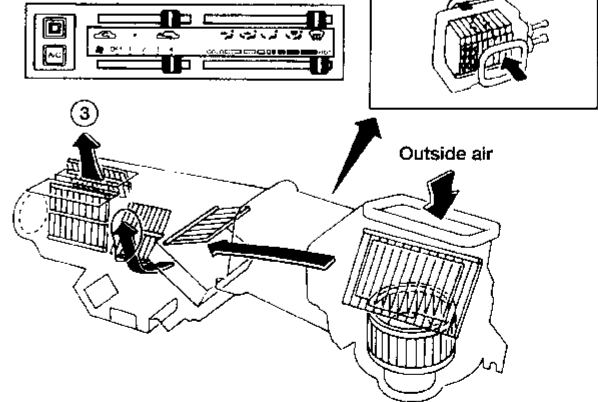

- ① : To face
- ② : To foot
- ③ : To defrost
- * : When in REC position

GI
MA
EM
LC
EC
FE
CL
MT
AT
TF
PD
FA
RA
BR
ST
RS
BT
HA
EL
IDX

DESCRIPTION

Control Operation

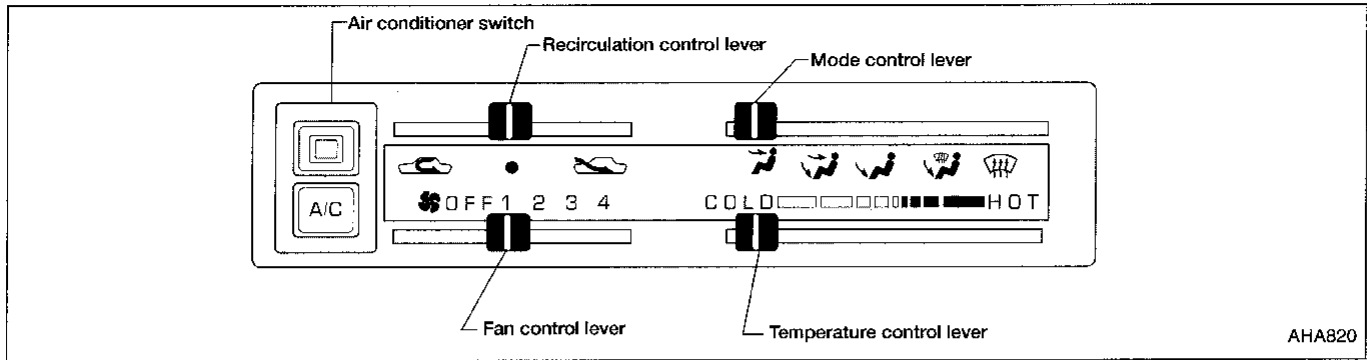

FAN CONTROL LEVER

This lever controls fan speed and turns the fan ON and OFF.

MODE CONTROL LEVER

This lever controls the outlet air flow.

TEMPERATURE CONTROL LEVER

This lever allows adjustment of the temperature of the outlet air.

RECIRCULATION CONTROL LEVER

FRESH  position:

Outside air is drawn into the passenger compartment.

Recirculation REC  position:

Interior air is recirculated inside the vehicle.

AIR CONDITIONER SWITCH

The air conditioner switch controls the A/C system. When the switch is depressed with the fan ON, the compressor will turn ON. The indicator lamp will also light.

The air conditioner cooling function operates only when the engine is running.

TROUBLE DIAGNOSES

How to Perform Trouble Diagnoses for Quick and Accurate Repair

WORK FLOW

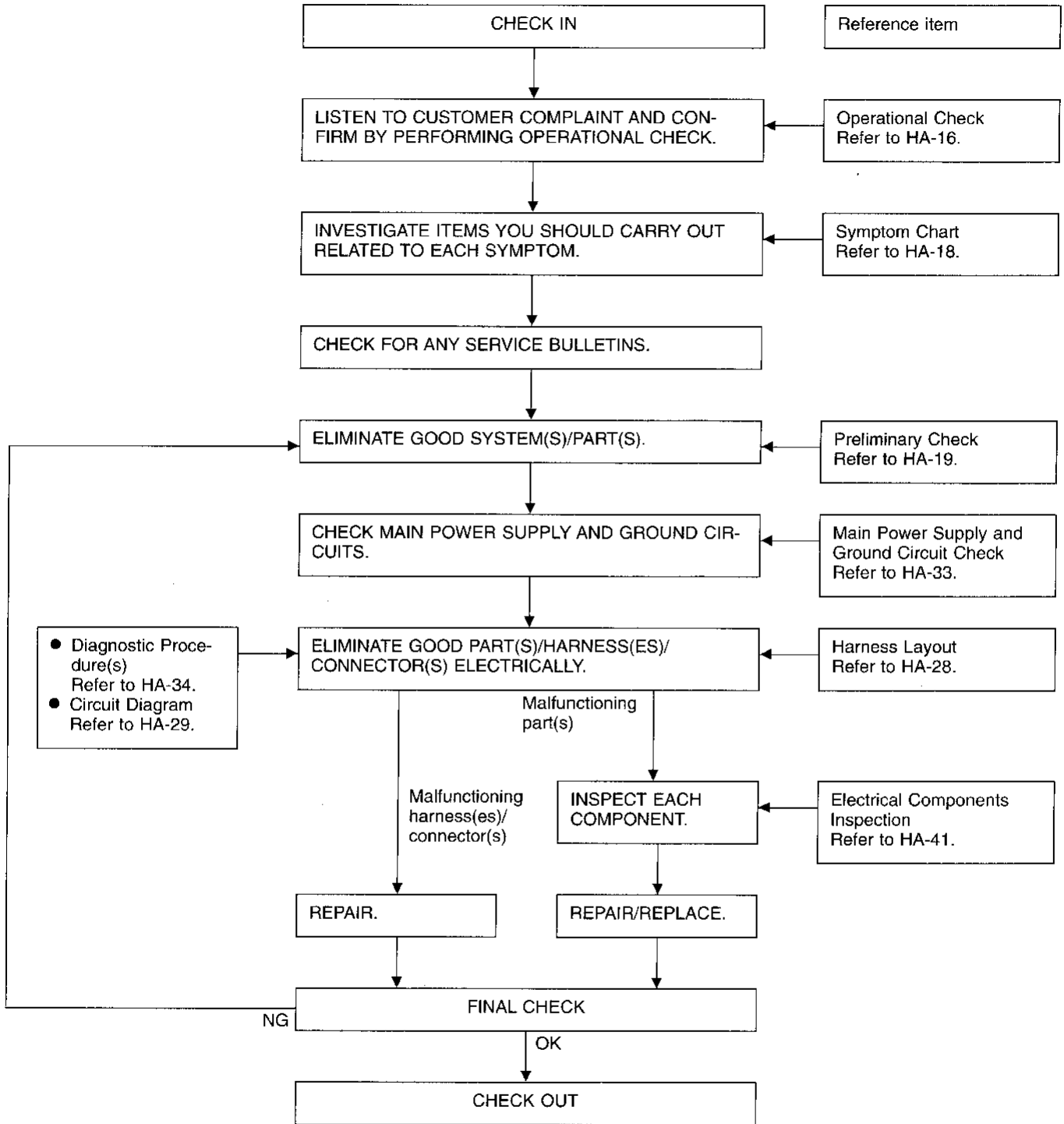

GI
MA
EM
LC
EC
FE
CL
MT
AT
TF
FD
EA
RA
BR
ST
RS
BT
HA
EL
DX

TROUBLE DIAGNOSES

Operational Check

The purpose of the operational check is to confirm that the system operates properly.

CONDITIONS:

- Engine running at normal operating temperature.

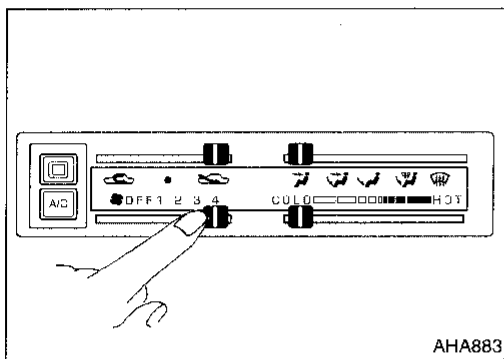



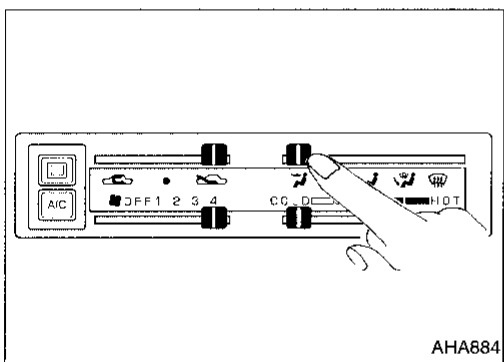

PROCEDURE:

1. Check blower

- Slide fan control lever to 1-speed. Blower should operate on 1-speed.
- Slide fan control lever to 2-speed and continue checking blower speed until all speeds are checked.
- Leave blower on 4-speed.



2. Check discharge air

- Slide mode control lever to  position.
- Confirm that all discharge air comes out of face vents.
- Slide mode control lever to  position.
- Confirm that discharge air comes out of face vents and foot vents.
- Slide mode control lever to  position.
- Confirm that discharge air comes out of foot vents, with some air from defrost vents.
- Slide mode control lever to  position.
- Confirm that discharge air comes out of foot vents with some air from defrost vents.
- Slide mode control lever to  position.
- Confirm that all discharge air comes out of defrost vents.

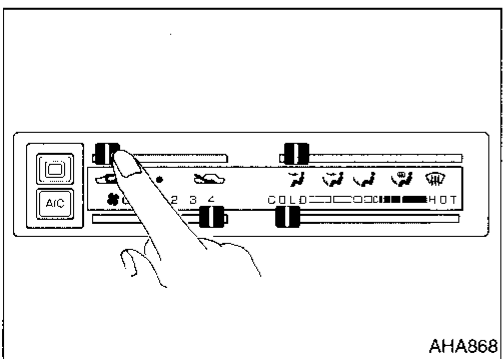

3. Check recirculation

- Slide recirculation control lever to the REC  position.
- Listen for intake door position change (you should hear blower sound change slightly).

TROUBLE DIAGNOSES

Operational Check (Cont'd)

4. Check temperature decrease

- Slide temperature control lever to full cold.
- Check for cold air at discharge air outlets.

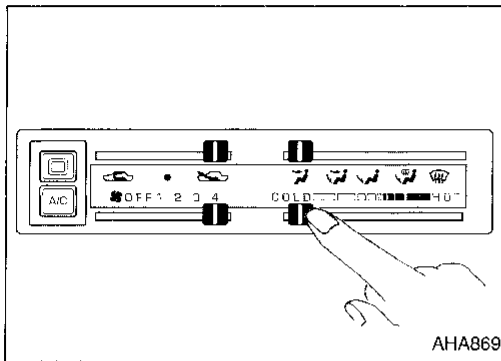

5. Check temperature increase

- Slide temperature control lever to full hot.
- Check for hot air at discharge air outlets.

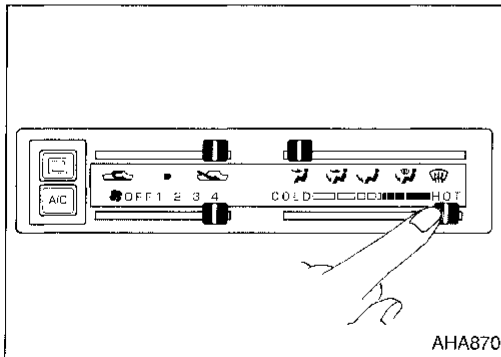

6. Check A/C switch

Move fan control lever to the desired position (1 to 4) and press air conditioner switch to turn air conditioner ON. Indicator light will come on when air conditioner is ON.

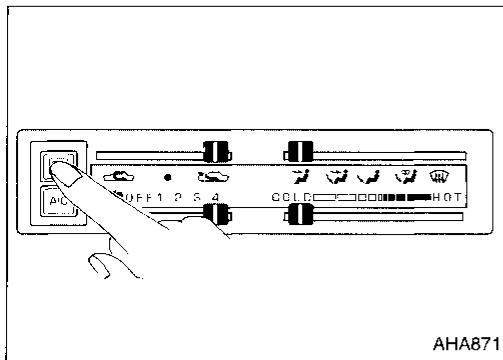

GI

MA

EM

LC

EC

FE

CL

MT

AT

TF

PD

FA

RA

BR

ST

RS

BT

HA

EL

IDX

TROUBLE DIAGNOSES

Symptom Chart

DIAGNOSTIC TABLE

PROCEDURE	Preliminary Check			Diagnostic Procedure		Main Power Supply and Ground Circuit Check			Electrical Components Inspection									
	HA-19	HA-20	HA-21	HA-34	HA-37	HA-33			HA-41	HA-41	HA-41	HA-41	HA-42	HA-42	HA-41	HA-53	HA-42	—
REFERENCE PAGE	HA-19	HA-20	HA-21	HA-34	HA-37	HA-33			HA-41	HA-41	HA-41	HA-41	HA-42	HA-42	HA-41	HA-53	HA-42	—
SYMPTOM	Preliminary check 1	Preliminary check 2	Preliminary check 3	Diagnostic procedure 1	Diagnostic procedure 2	15A Fuses (Nos. 4 and 5)	10A Fuse (No. 6)	15A Fuse (No. 3)	Blower motor	Resistor	A/C switch	Fan switch	Blower motor relay	A/C relay	Dual-pressure switch	Magnet clutch	Thermal protector	Harness
A/C does not blow cold air.	①			○		○	○	○	○	○	○	○	○	○	○	○	○	○
Blower motor does not rotate.	①			②		○			○	○		○	○					○
Magnet clutch does not engage when A/C switch and fan switch are ON.	①				②		○	○			○	○	○	○		○	○	○
Noise.		①																
Insufficient heating.			①	○														○

①, ② : The number means checking order.
 ○ : Checking order depends on malfunction in flow chart.

TROUBLE DIAGNOSES

Preliminary Check

PRELIMINARY CHECK 1

A/C does not blow cold air.

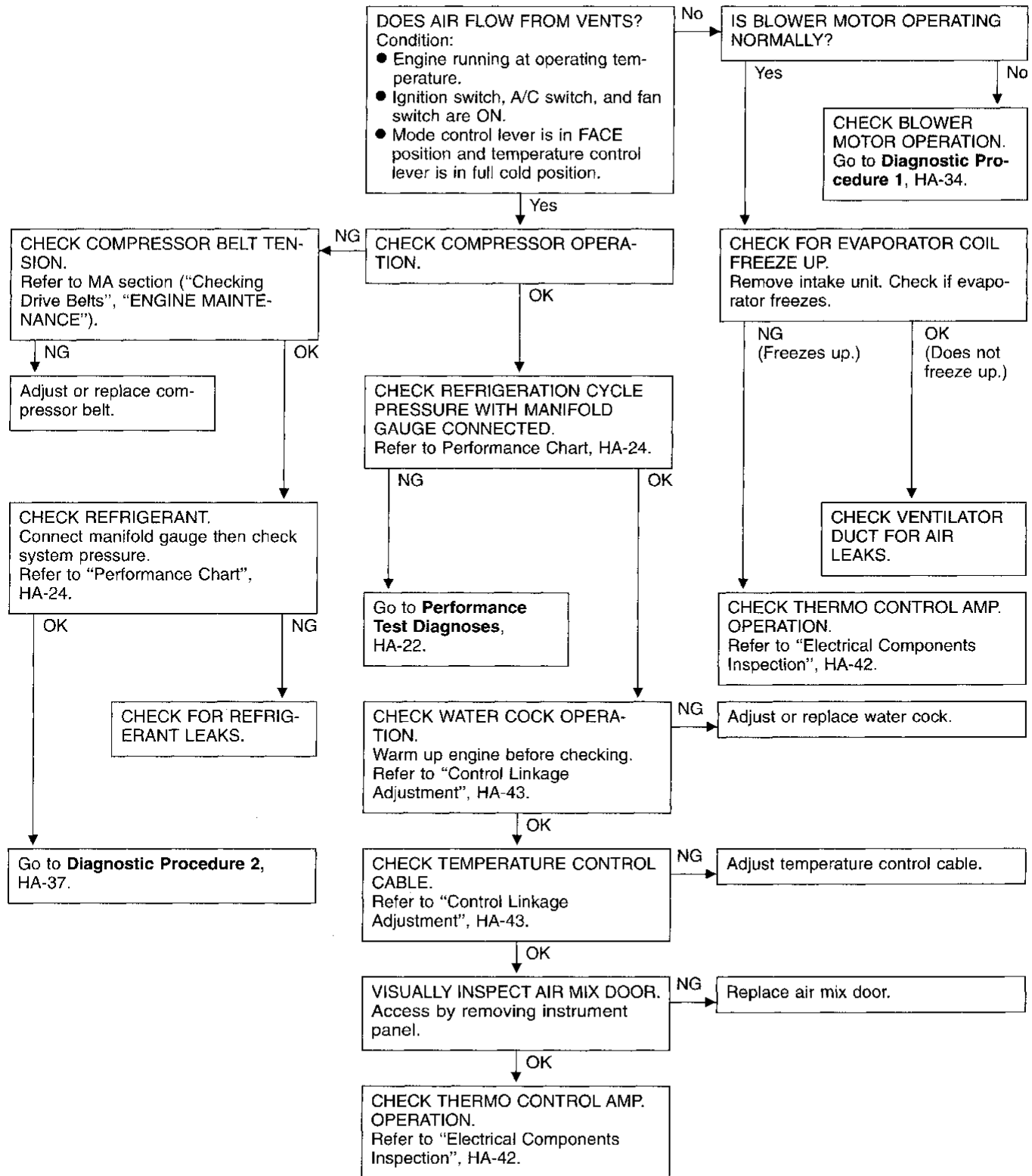

GI
MA
EM
LC
EC
FE
CL
MT
AT
TF
PD
FA
RA
BR
ST
RS
BT
HA
EL
IDX

TROUBLE DIAGNOSES

Preliminary Check (Cont'd)

PRELIMINARY CHECK 2

Noise.

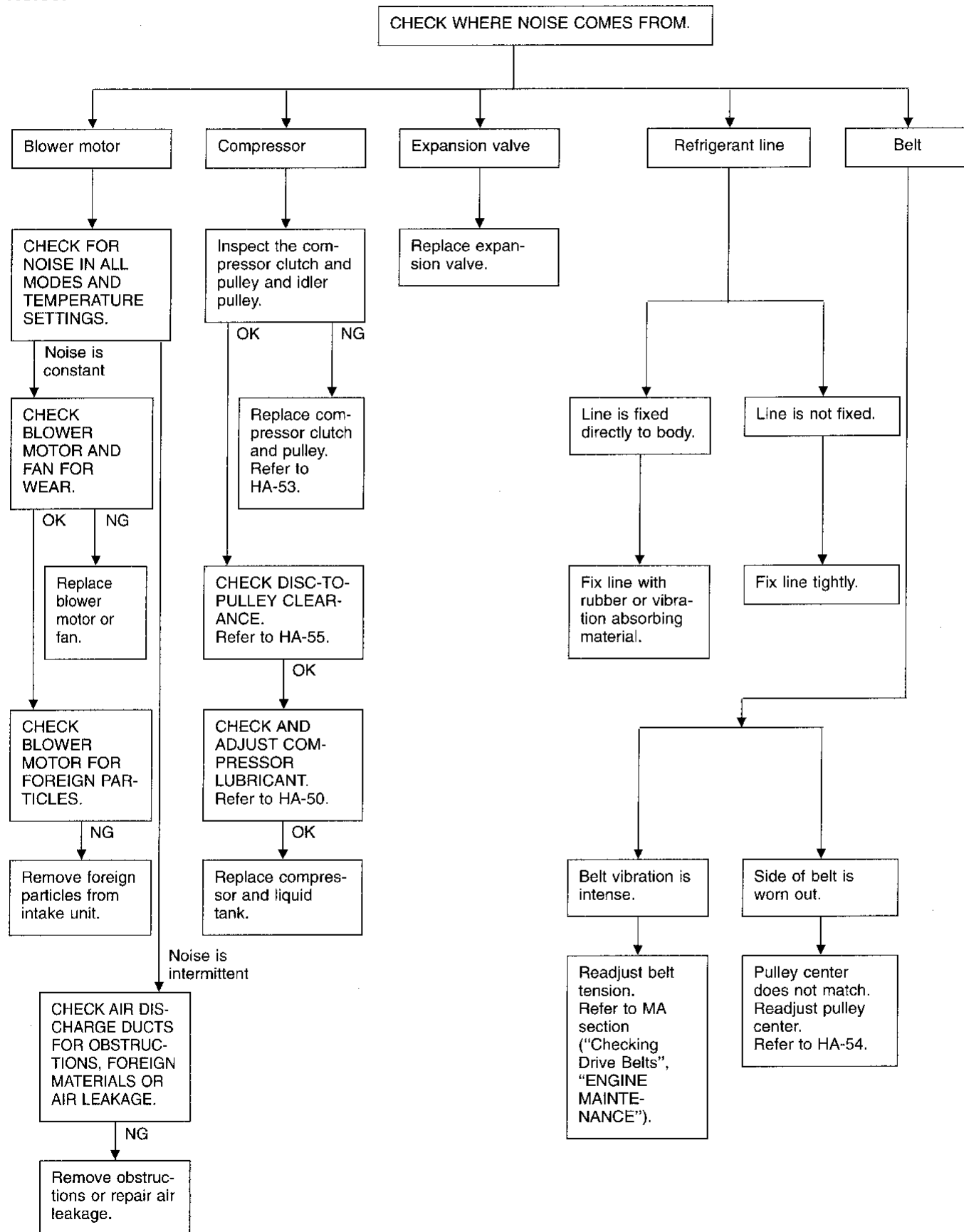

TROUBLE DIAGNOSES

Preliminary Check (Cont'd)

PRELIMINARY CHECK 3

Insufficient heating.

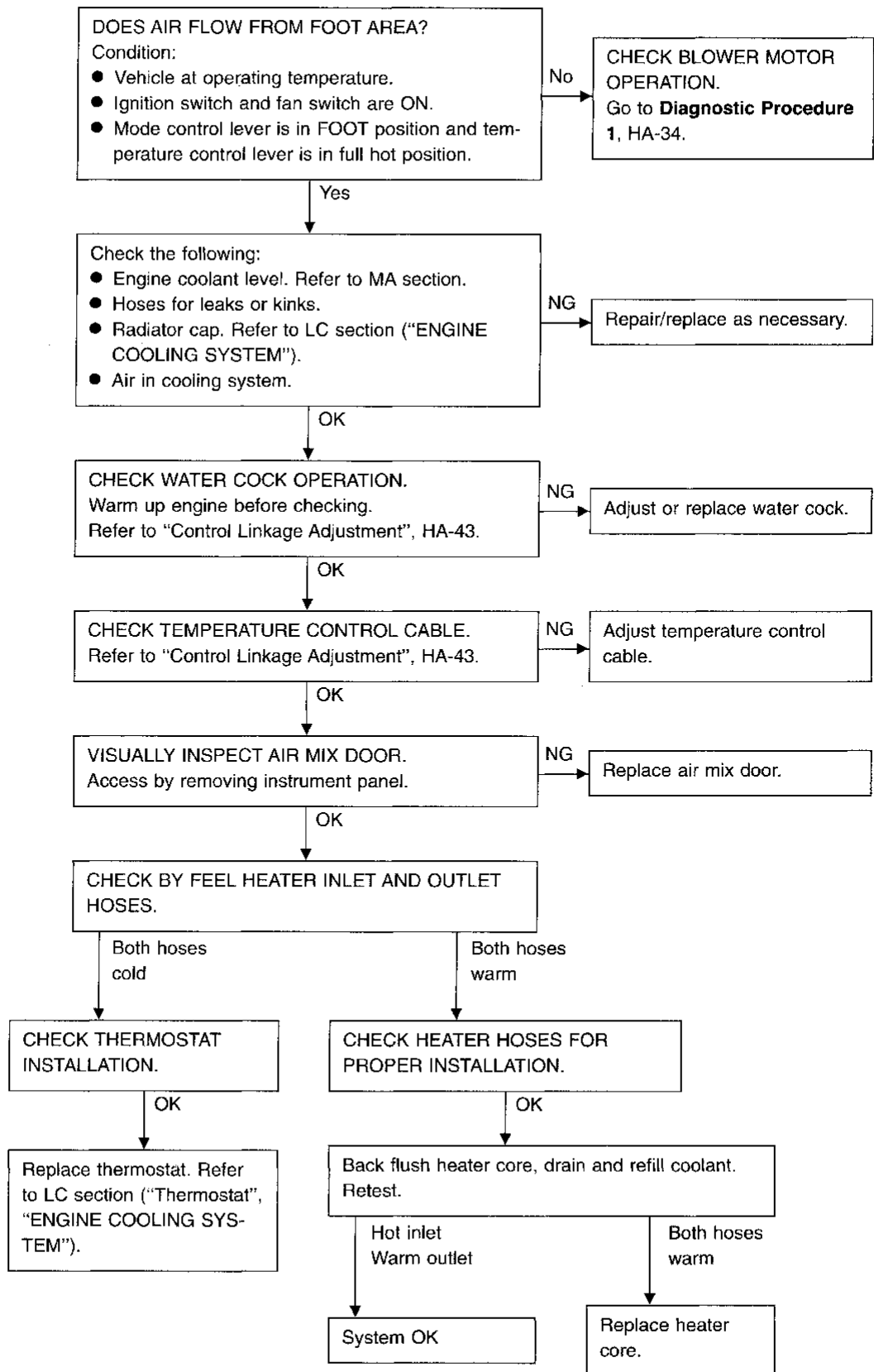

GI

MA

EM

LC

EC

FE

CL

WT

AT

TF

PD

FA

RA

BR

ST

RS

BT

HA

EL

IDX

TROUBLE DIAGNOSES

Performance Test Diagnoses

INSUFFICIENT COOLING

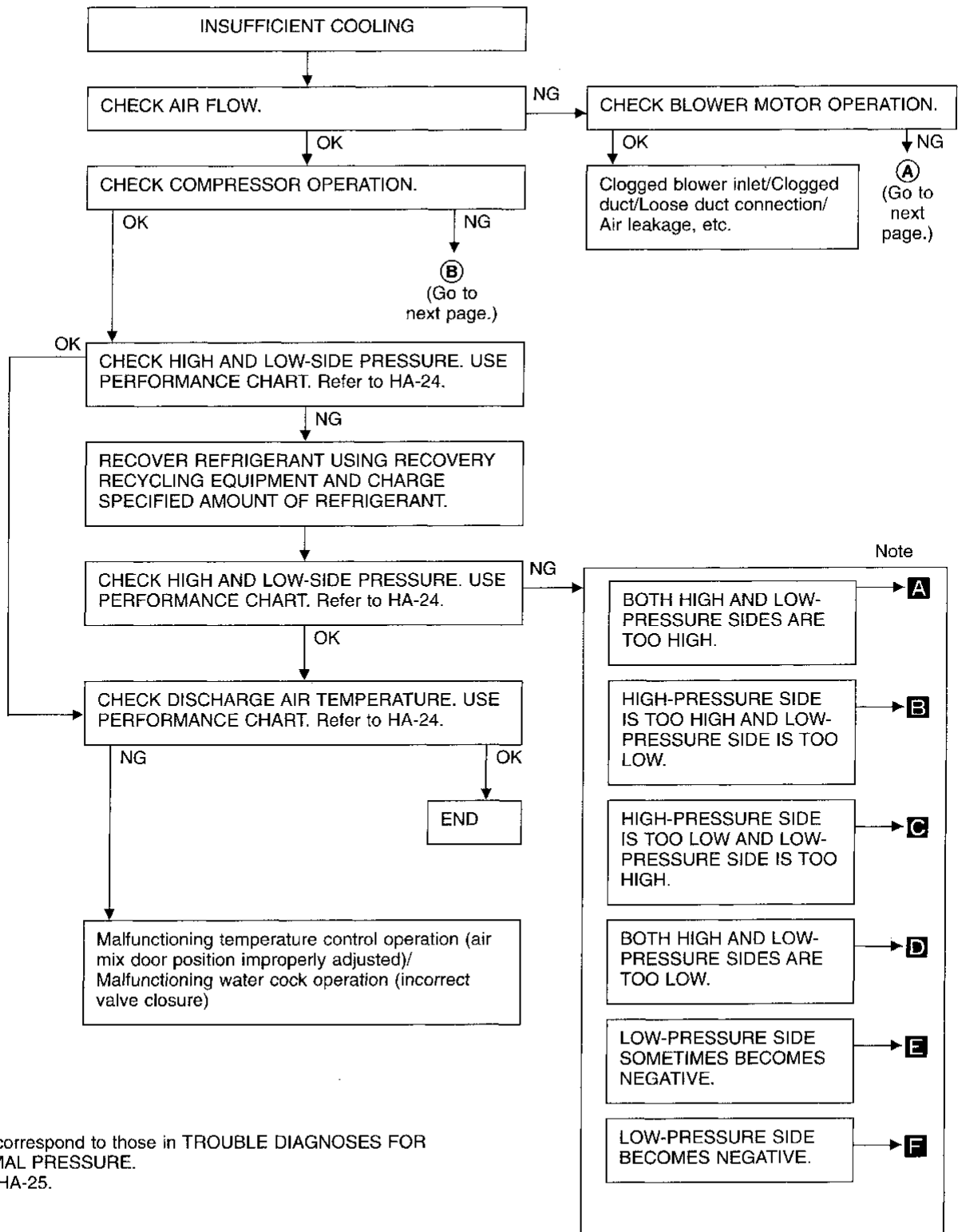

Note: **A-F** correspond to those in TROUBLE DIAGNOSES FOR ABNORMAL PRESSURE. Refer to HA-25.

TROUBLE DIAGNOSES

Performance Test Diagnoses (Cont'd)

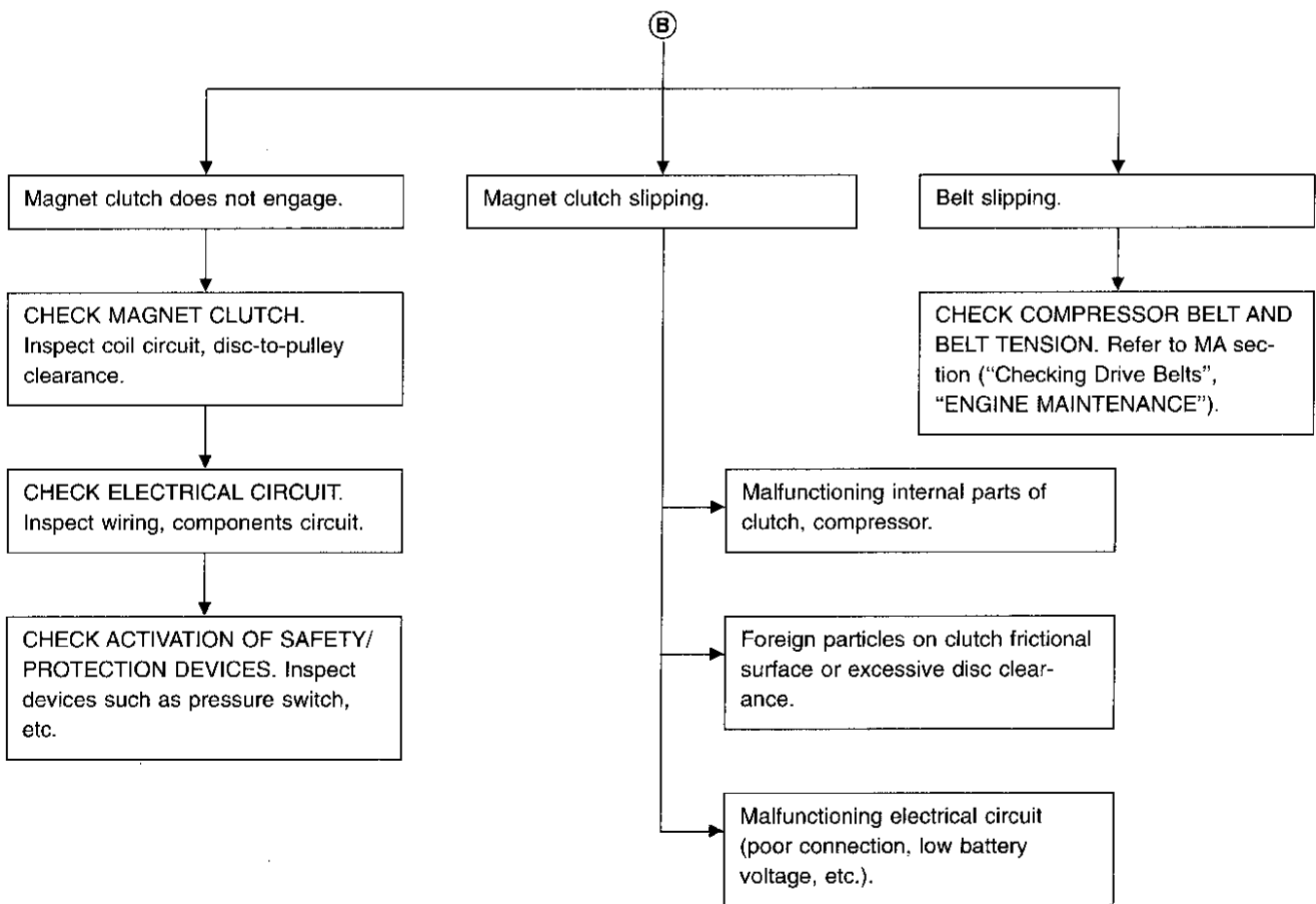
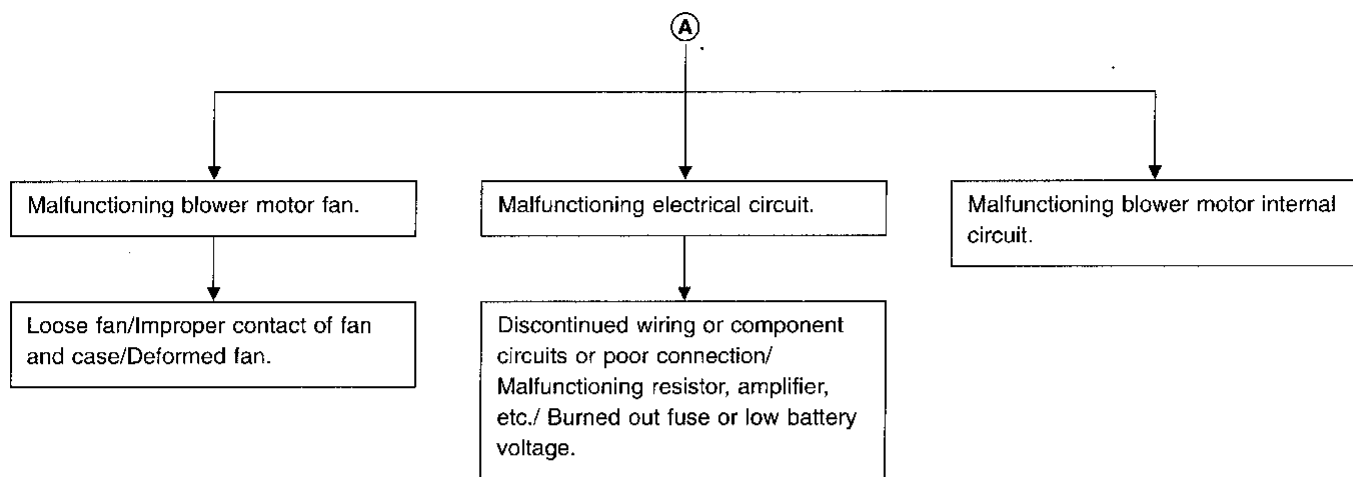

GI
MA
EM
LC
EC
FE
CL
MT
AT
TF
PD
FA
PA
BR
ST
RS
BT
HA
EL
IDX

TROUBLE DIAGNOSES

Performance Chart

TEST CONDITION

Testing must be performed as follows:

Vehicle location: Indoors or in the shade (in a well-ventilated place)

Doors: Closed

Door window: Open

Hood: Open

TEMP. setting: Max. COLD

Discharge air: FACE VENT

INTAKE lever position:  (Recirculation)

FAN speed: 4-speed

Engine speed: 1,500 rpm

Operate the air conditioner system for 10 minutes before taking measurements.

TEST READING

Recirculating-to-discharge air temperature table

Inside air (Recirculating air) at blower assembly inlet		Discharge air temperature at center ventilator °C (°F)
Relative humidity %	Air temperature °C (°F)	
50 - 60	20 (68)	6.6 - 8.3 (44 - 47)
	25 (77)	10.4 - 12.4 (51 - 54)
	30 (86)	14.2 - 16.7 (58 - 62)
	35 (95)	18.2 - 21.0 (65 - 70)
	40 (104)	22.0 - 25.2 (72 - 77)
60 - 70	20 (68)	8.3 - 9.8 (47 - 50)
	25 (77)	12.4 - 14.4 (54 - 58)
	30 (86)	16.7 - 18.9 (62 - 66)
	35 (95)	21.0 - 23.6 (70 - 74)
	40 (104)	25.2 - 28.1 (77 - 83)

Ambient air temperature-to-operating pressure table

Ambient air		High-pressure (Discharge side) kPa (kg/cm ² , psi)	Low-pressure (Suction side) kPa (kg/cm ² , psi)
Relative humidity %	Air temperature °C (°F)		
50 - 70	20 (68)	961 - 1,187 (9.8 - 12.1, 139 - 172)	108 - 157 (1.1 - 1.6, 16 - 23)
	25 (77)	1,295 - 1,599 (13.2 - 16.3, 188 - 232)	161.8 - 215.8 (1.65 - 2.2, 23.5 - 31.3)
	30 (86)	1,285 - 1,569 (13.1 - 16, 186 - 228)	167 - 216 (1.7 - 2.2, 24 - 31)
	35 (95)	1,520 - 1,863 (15.5 - 19, 220 - 270)	235 - 284 (2.4 - 2.9, 34 - 41)
	40 (104)	1,765 - 2,158 (18 - 22, 256 - 313)	289.3 - 353.1 (2.95 - 3.6, 41.9 - 51.2)

TROUBLE DIAGNOSES

Trouble Diagnoses for Abnormal Pressure

Whenever system's high or low-pressure side is abnormal, diagnose using a manifold gauge. The marker above the gauge scale in the following table indicates the standard (normal) pressure range. Since the standard (normal) pressure differs from vehicle to vehicle, refer to HA-24 ("Ambient air temperature-to-operating pressure table").

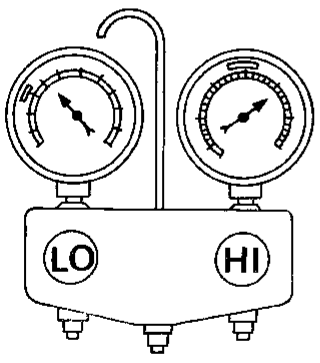
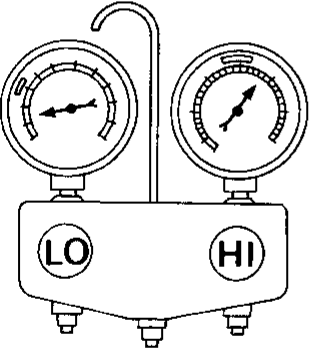
Gauge indication	Refrigerant cycle	Probable cause	Corrective action
<p>Both high and low-pressure sides are too high.</p> <p>A</p>  <p>AC359A</p>	<ul style="list-style-type: none"> Pressure is reduced soon after water is splashed on condenser. 	<p>Excessive refrigerant charge in refrigeration cycle.</p>	<p>Reduce refrigerant until specified pressure is obtained.</p>
	<p>Air suction by cooling fan is insufficient.</p>	<p>Insufficient condenser cooling performance.</p> <p>↓</p> <ol style="list-style-type: none"> Condenser fins are clogged. Improper fan rotation of cooling fan. 	<ul style="list-style-type: none"> Clean condenser. Check and repair cooling fan as necessary.
	<ul style="list-style-type: none"> Low-pressure pipe is not cold. When compressor is stopped high-pressure value quickly drops by approximately 196 kPa (2 kg/cm², 28 psi). It then decreases gradually thereafter. 	<p>Poor heat exchange in condenser.</p> <p>(After compressor operation stops, high pressure decreases too slowly.)</p> <p>↓</p> <p>Air in refrigeration cycle.</p>	<p>Evacuate repeatedly and recharge system.</p>
	<p>Engine tends to overheat.</p>	<p>Engine cooling systems malfunction.</p>	<p>Check and repair each engine cooling system.</p>
	<ul style="list-style-type: none"> An area of the low-pressure pipe is colder than areas near the evaporator outlet. Plates are sometimes covered with frost. 	<ul style="list-style-type: none"> Excessive liquid refrigerant on low-pressure side. Excessive refrigerant discharge flow. Expansion valve is open a little compared with the specification. <p>↓</p> <ol style="list-style-type: none"> Improper thermal valve installation. Improper expansion valve adjustment. 	<p>Replace expansion valve.</p>
<p>High-pressure side is too high and low-pressure side is too low.</p> <p>B</p>  <p>AC360A</p>	<p>Upper side of condenser and high-pressure side are hot, however, liquid tank is not so hot.</p>	<p>High-pressure tube or parts located between compressor and condenser are clogged or crushed.</p>	<ul style="list-style-type: none"> Check and repair or replace malfunctioning parts. Check lubricant for contamination.

TROUBLE DIAGNOSES

Trouble Diagnoses for Abnormal Pressure (Cont'd)

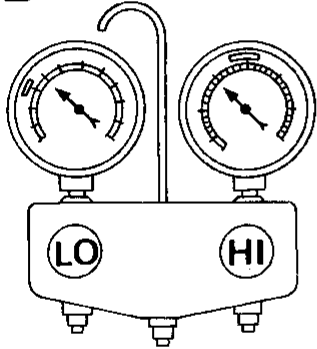
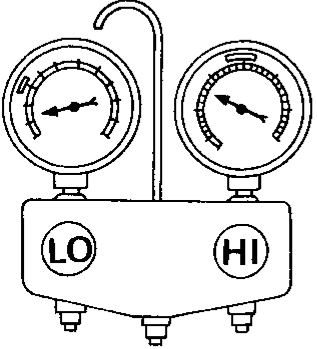
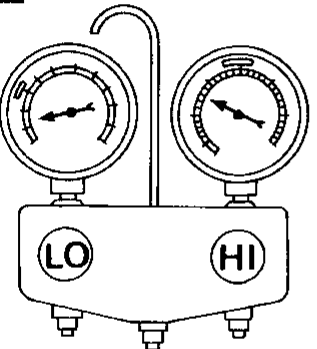
Gauge indication	Refrigerant cycle	Probable cause	Corrective action
High-pressure side is too low and low-pressure side is too high. C  AC356A	High and low-pressure sides become equal soon after compressor operation stops.	Compressor pressure operation is improper. ↓ Damaged inside compressor packings.	Replace compressor.
	No temperature difference between high and low-pressure sides.	Compressor pressure operation is improper. ↓ Damaged inside compressor packings.	Replace compressor.
Both high and low-pressure sides are too low. D  AC353A	<ul style="list-style-type: none"> ● There is a big temperature difference between receiver drier outlet and inlet. Outlet temperature is extremely low. ● Liquid tank inlet and expansion valve are frosted. 	Liquid tank inside is clogged a little.	<ul style="list-style-type: none"> ● Replace liquid tank. ● Check lubricant for contamination.
	<ul style="list-style-type: none"> ● Temperature of expansion valve inlet is extremely low as compared with areas near liquid tank. ● Expansion valve inlet may be frosted. ● Temperature difference occurs somewhere in high-pressure side. 	High-pressure pipe located between liquid tank and expansion valve is clogged.	<ul style="list-style-type: none"> ● Check and repair malfunctioning parts. ● Check lubricant for contamination.
Both high and low-pressure sides are too low. D  AC353A	<ul style="list-style-type: none"> ● Expansion valve and liquid tank are warm or only cool when touched. 	Low refrigerant charge. ↓ Leaking fittings or components.	Check refrigerant for leaks. Refer to "Checking Refrigerant Leaks", HA-44.
	There is a big temperature difference between expansion valve inlet and outlet while the valve itself is frosted.	Expansion valve closes a little compared with the specification. ↓ ① Improper expansion valve adjustment. ② Malfunctioning thermal valve. ③ Outlet and inlet may be clogged.	<ul style="list-style-type: none"> ● Remove foreign particles by using compressed air. ● Check lubricant for contamination.
	An area of the low-pressure pipe is colder than areas near the evaporator outlet.	Low-pressure pipe is clogged or crushed.	<ul style="list-style-type: none"> ● Check and repair malfunctioning parts. ● Check lubricant for contamination.
	Air flow volume is not enough or is too low.	Compressor pressure operation is improper.	Replace compressor.

TROUBLE DIAGNOSES

Trouble Diagnoses for Abnormal Pressure (Cont'd)

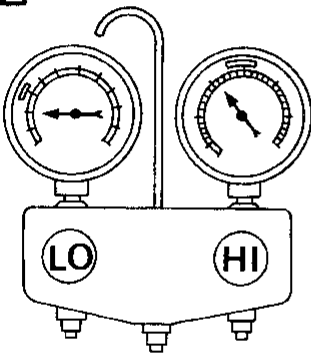
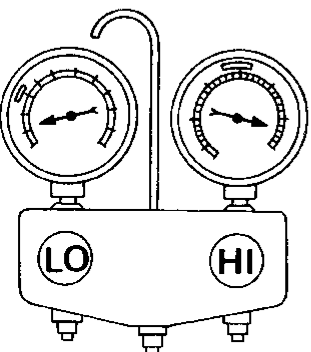
Gauge indication	Refrigerant cycle	Probable cause	Corrective action
<p>Low-pressure side sometimes becomes negative.</p> <p>E</p>  <p style="text-align: right;">AC354A</p>	<ul style="list-style-type: none"> ● Air conditioner system does not function and does not cyclically cool the compartment air. ● The system constantly functions for a certain period of time after compressor is stopped and restarted. 	<p>Refrigerant does not discharge cyclically.</p> <p style="text-align: center;">↓</p> <p>Moisture is frozen at expansion valve outlet and inlet.</p> <p style="text-align: center;">↓</p> <p>Water is mixed with refrigerant.</p>	<ul style="list-style-type: none"> ● Drain water from refrigerant or replace refrigerant. ● Replace liquid tank.
<p>Low-pressure side becomes negative.</p> <p>F</p>  <p style="text-align: right;">AC362A</p>	<p>Liquid tank or front/rear side of expansion valve's pipe is frosted or dewed.</p>	<p>High-pressure side is closed and refrigerant does not flow.</p> <p style="text-align: center;">↓</p> <p>Expansion valve or liquid tank is frosted.</p>	<p>Leave the system at rest. Start it again to check whether or not the problem is caused by water or foreign particles.</p> <ul style="list-style-type: none"> ● If water is the cause, initially cooling is okay. Then the water freezes, causing a blockage. Drain water from refrigerant or replace refrigerant. ● If due to foreign particles, remove expansion valve and remove the particles with dry and compressed air. ● If either of the above methods cannot correct the problem, replace expansion valve. ● Replace liquid tank. ● Check lubricant for contamination.

GI

MA

EM

LC

EC

FE

CL

MT

AT

TF

PD

FA

RA

BR

ST

RS

BT

HA

EL

IDX

TROUBLE DIAGNOSES

Harness Layout

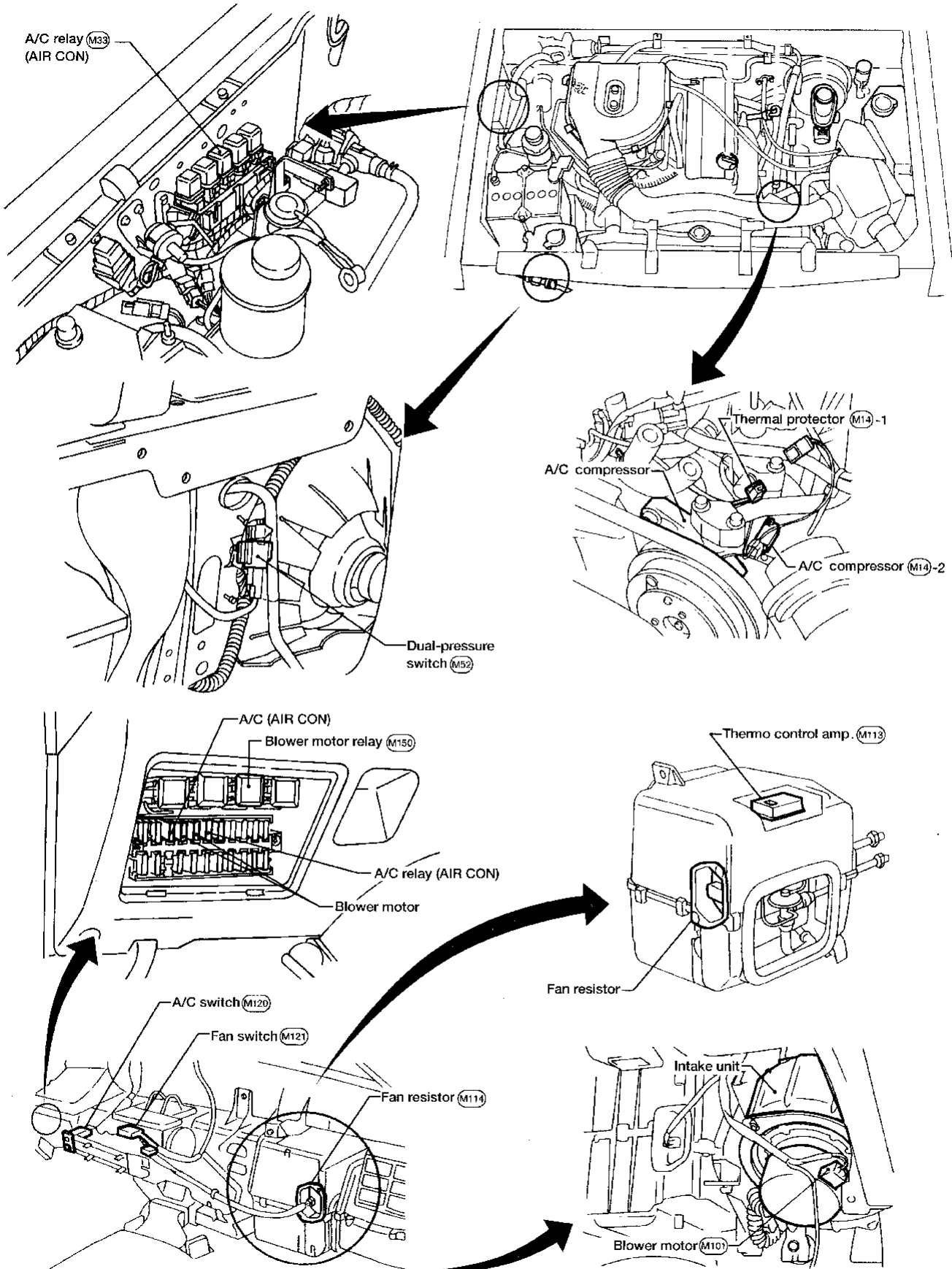

TROUBLE DIAGNOSES

Wiring Diagram -HEATER-

HA-HEATER-01

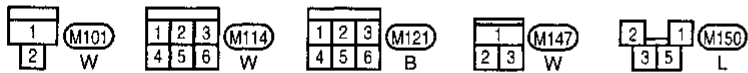
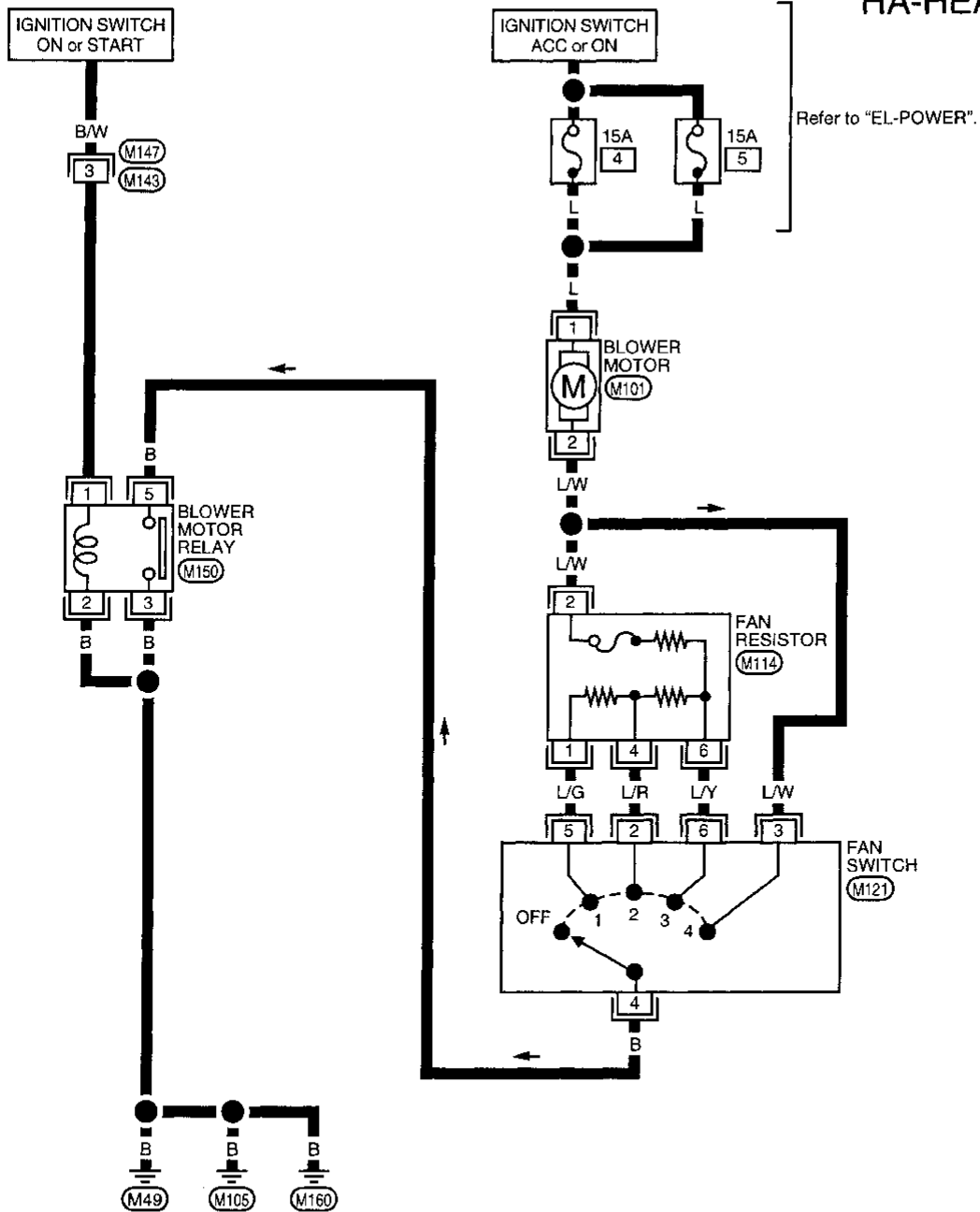

TROUBLE DIAGNOSES

Wiring Diagram -A/C- (Cont'd)

HA-A/C-02

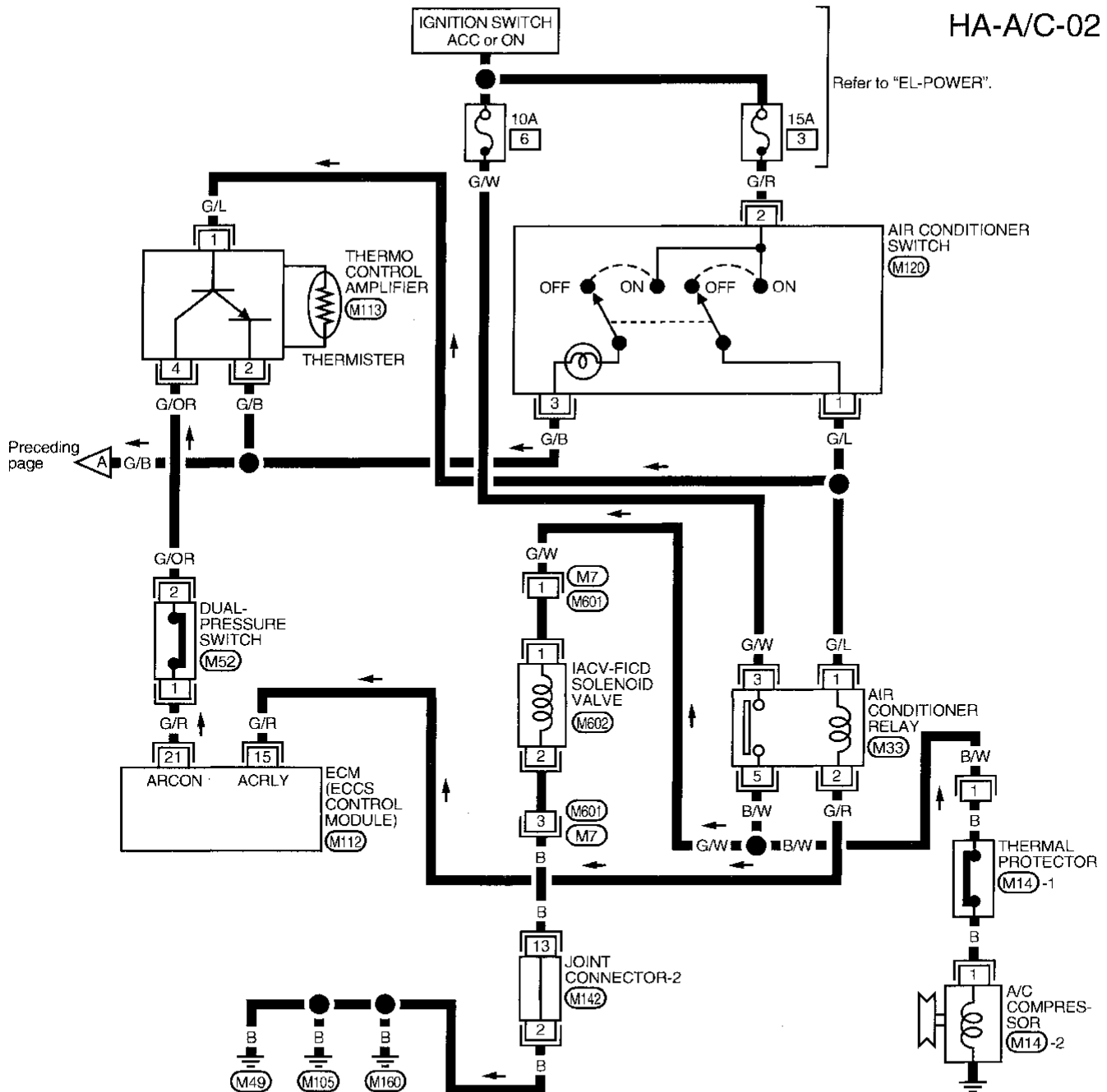

Refer to last page (Foldout page).

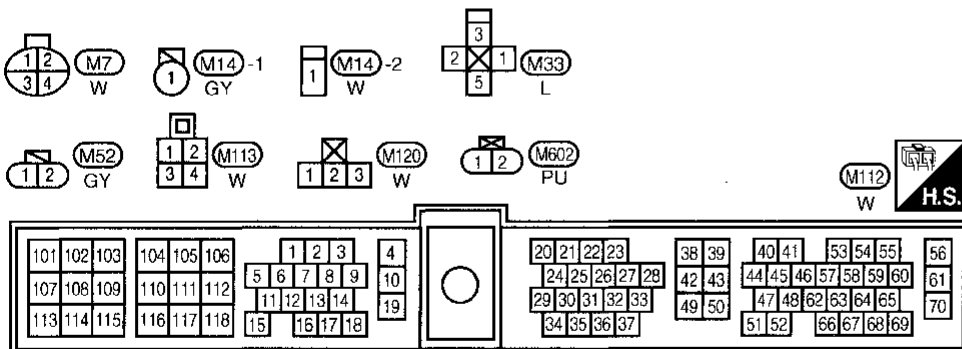

Main Power Supply and Ground Circuit Check

POWER SUPPLY CIRCUIT CHECK FOR A/C SYSTEM

Check power supply circuit for air conditioner system.

Refer to "POWER SUPPLY ROUTING" in EL section and "Wiring Diagram".

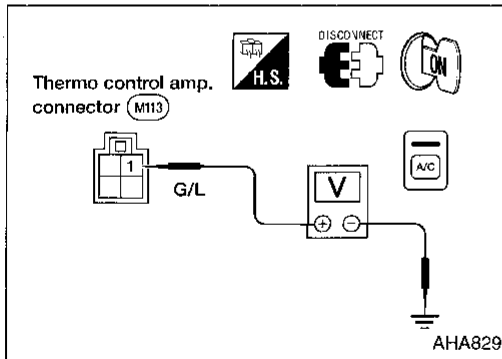

THERMO CONTROL AMP. CHECK

Check power supply circuit for thermo control amp. with ignition switch ON and air conditioner switch ON.

1. Disconnect thermo control amp. harness connector.
2. Connect voltmeter from harness side.
3. Measure voltage across terminal No. ① and body ground.

Voltmeter terminal		Voltage
⊕	⊖	
①	Body ground	Approx. 12V

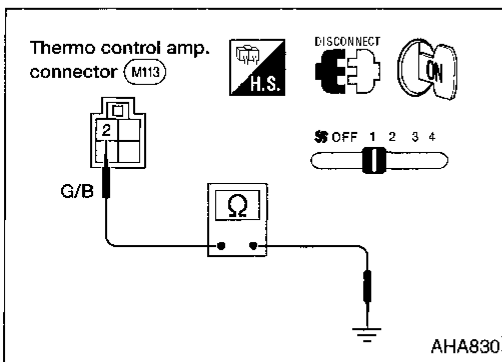

Check body ground circuit for thermo control amp. with ignition switch ON and fan switch ON.

1. Disconnect thermo control amp. harness connector.
2. Connect ohmmeter from harness side.
3. Check for continuity between terminal No. ② and body ground.

Ohmmeter terminal		Continuity
⊕	⊖	
②	Body ground	Yes

GI
 MA
 EM
 LC
 EC
 FE
 CL
 MT
 AT
 TF
 PD
 FA
 RA
 BR
 ST
 RS
 BT
 HA
 EL
 IDX

TROUBLE DIAGNOSES

	INCIDENT	Flow chart No.
1	Fan fails to rotate.	①
2	Fan does not rotate at 1-speed.	②
3	Fan does not rotate at 2-speed.	③
4	Fan does not rotate at 3-speed.	④
5	Fan does not rotate at 4-speed.	⑤

Diagnostic Procedure 1

SYMPTOM: Blower motor does not rotate.

- Perform **PRELIMINARY CHECK 1** before referring to the following flow chart.

Check if blower motor rotates properly at each fan speed.
Conduct check as per flow chart at left.

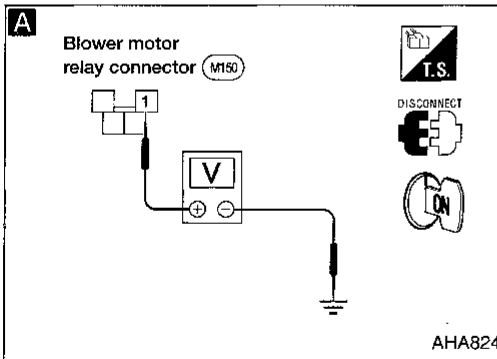
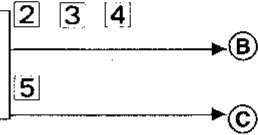

A (Go to HA-36.)

CHECK POWER SUPPLY FOR BLOWER MOTOR RELAY.
Do approx. 12 volts exist between blower motor relay harness terminal No. ① and body ground?

No → Check circuit between ignition switch and blower motor relay.
(Refer to "POWER SUPPLY ROUTING" in EL section and Wiring Diagram.)

Yes → **B**
Note: Check circuit continuity between blower motor relay harness terminals No. ②, ③ and body ground.

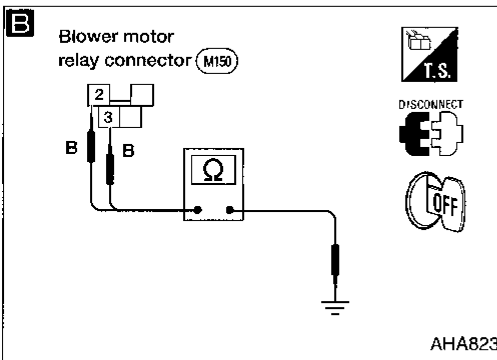

OK → **CHECK BLOWER MOTOR RELAY AFTER DISCONNECTING IT.**
Refer to HA-42.

NG → Replace blower motor relay.

OK → Reconnect blower motor relay.

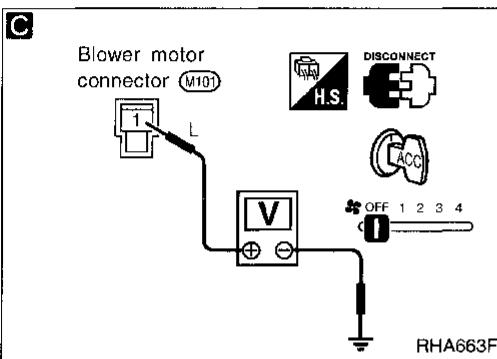

CHECK POWER SUPPLY FOR BLOWER MOTOR.
Disconnect blower motor harness connector.
Do approx. 12 volts exist between blower motor harness terminal No. ① and body ground?

No → Check power supply circuit and 15A fuses (No. ④ and ⑤, located in the fuse block).

Yes → **A**
(Go to next page.)

Note:
If the result is NG after checking circuit continuity, repair harness or connector.

TROUBLE DIAGNOSES

Diagnostic Procedure 1 (Cont'd)

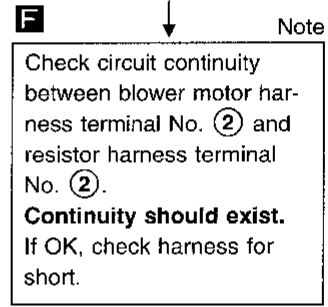
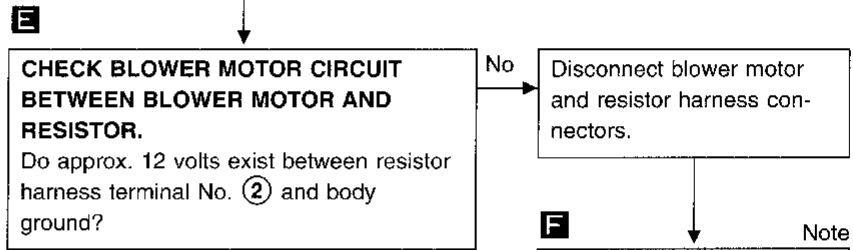
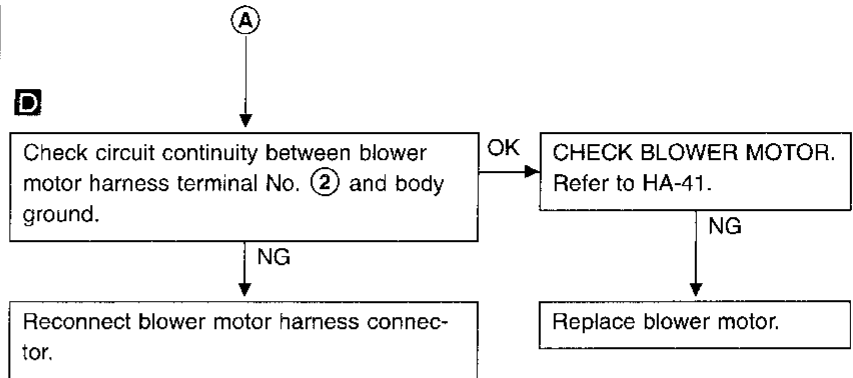
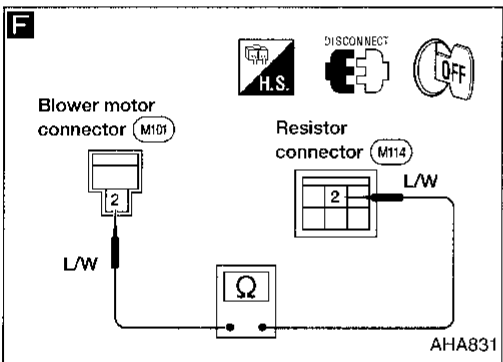
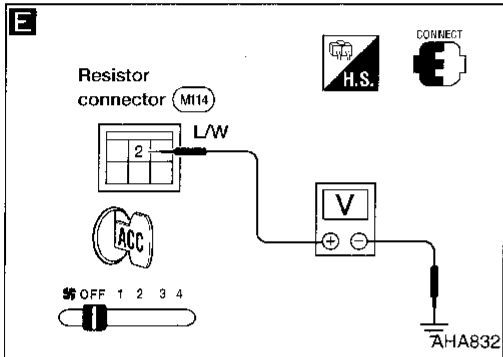
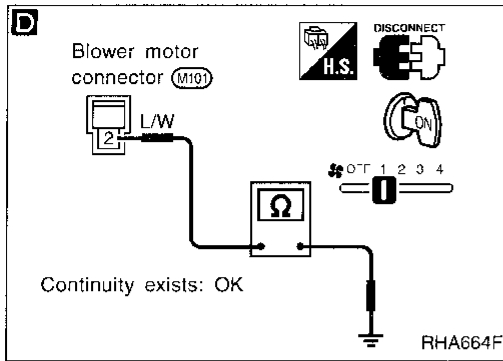

Note:
If the result is NG after checking circuit continuity, repair harness or connector.

CI
MA
EM
LC
EC
FE
CL
MT
AT
TF
PD
FA
RA
BR
ST
RS
BT
HA
EL
DX

TROUBLE DIAGNOSES

Diagnostic Procedure 1 (Cont'd)

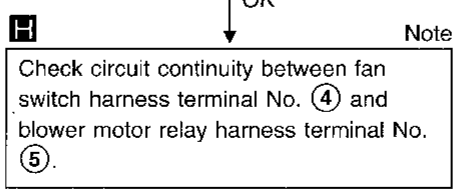
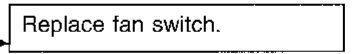
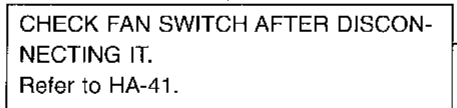
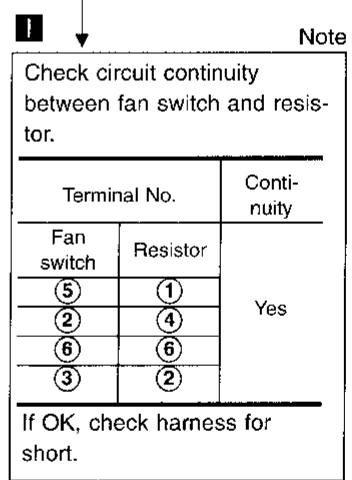
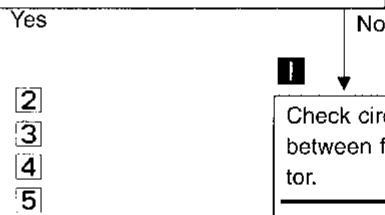
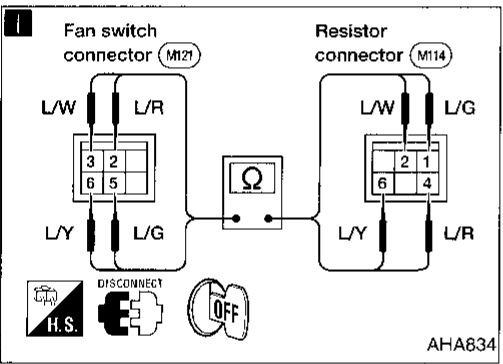
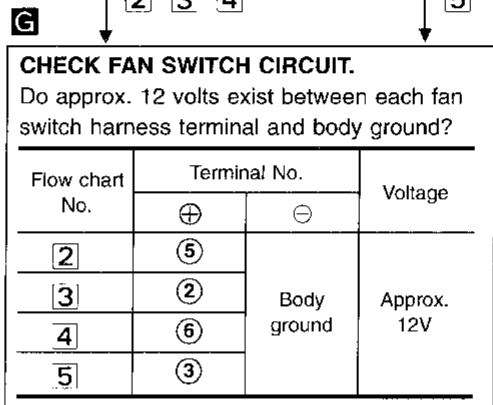
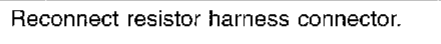
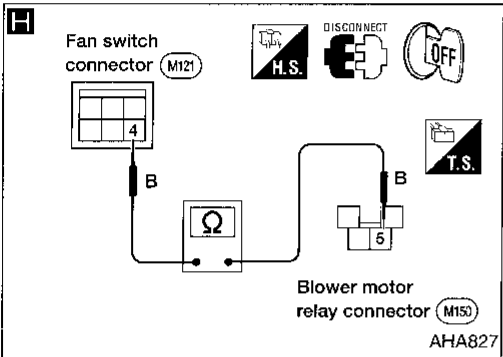
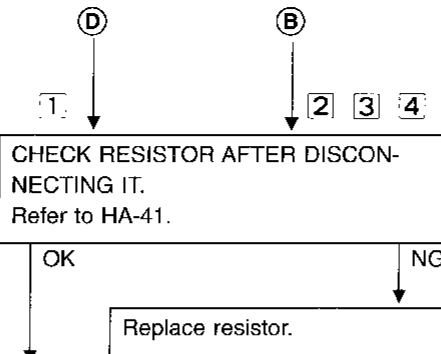
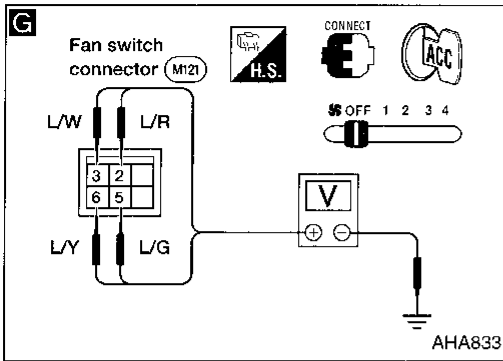

Note:
If the result is NG after checking circuit continuity, repair harness or connector.

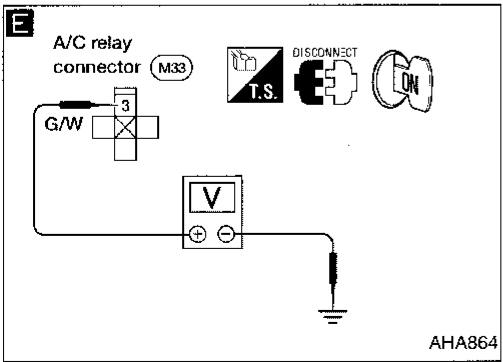
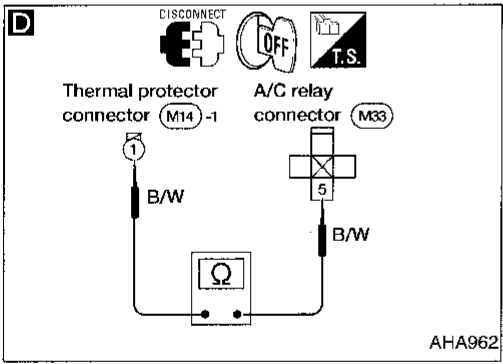
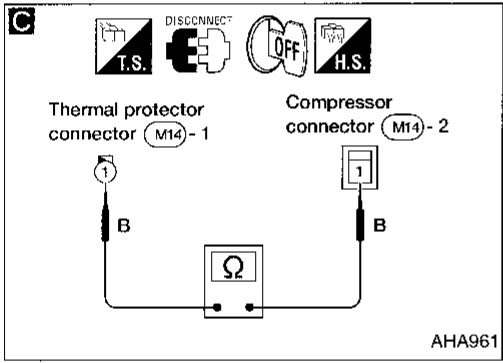
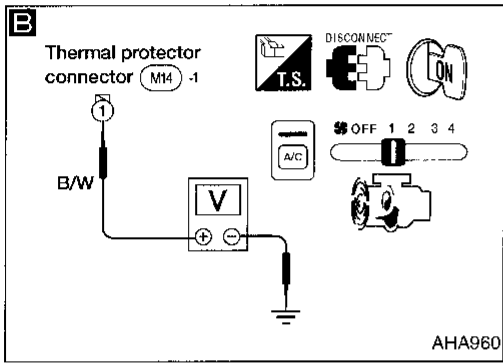
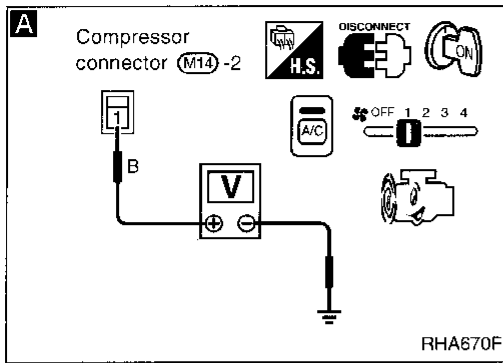

Diagnostic Procedure 2

SYMPTOM: Magnet clutch does not engage when A/C switch and fan switch are ON.

- Perform PRELIMINARY CHECK 1 before referring to the following flow chart.

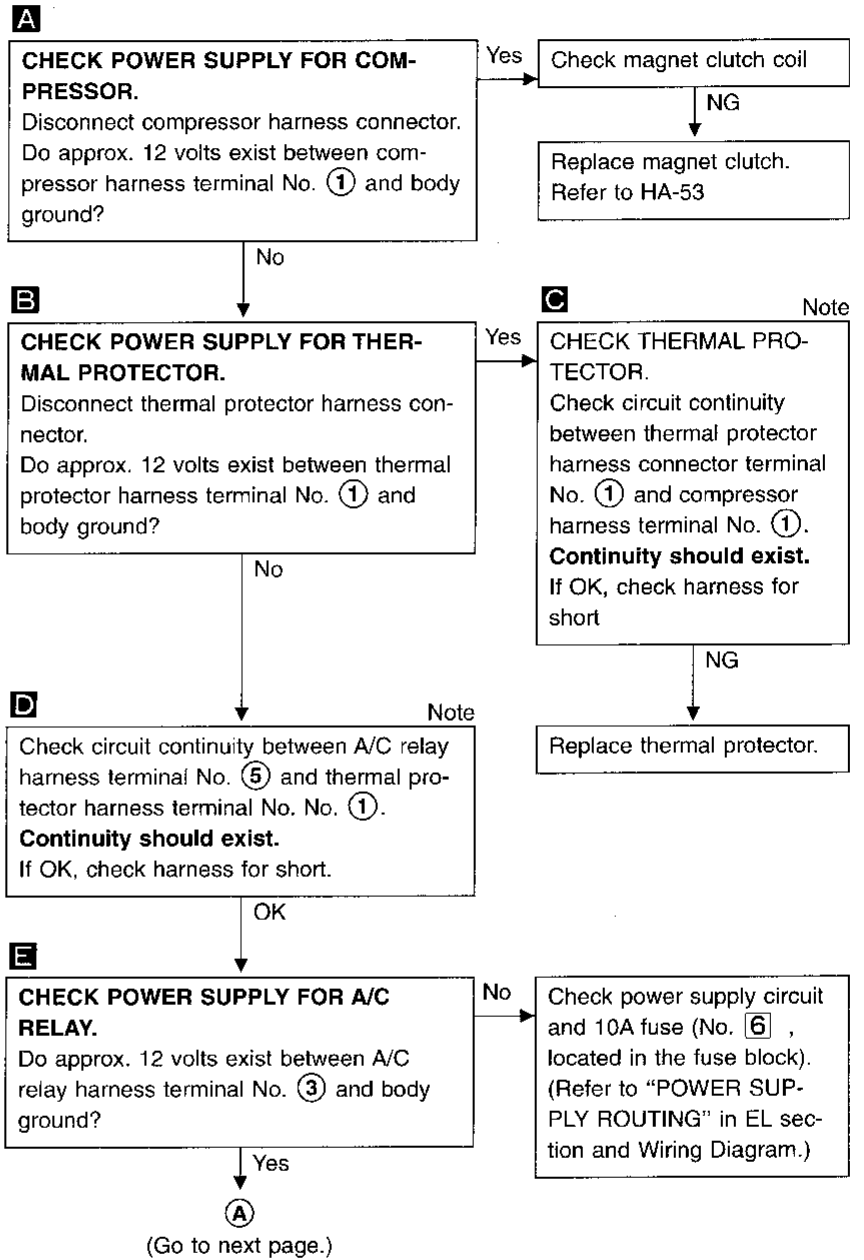

Note:
If the result is NG after checking circuit continuity, repair harness or connector.

GI
MA
EM
LC
EC
FE
CL
MT
AT
TF
PD
FA
RA
BR
ST
RS
BT
HA
EL
IOX

TROUBLE DIAGNOSES

Diagnostic Procedure 2 (Cont'd)

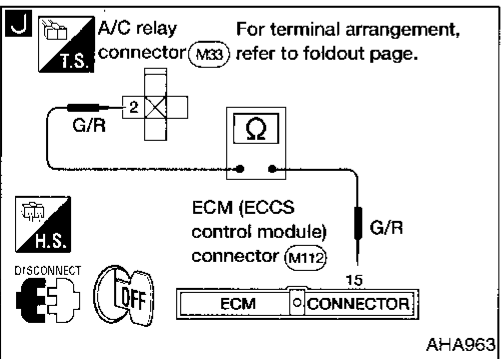
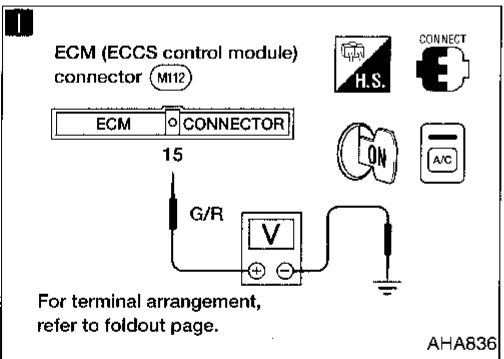
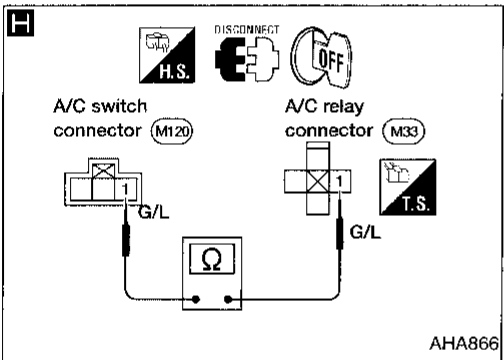
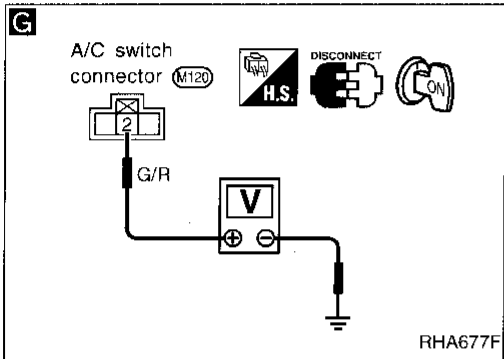
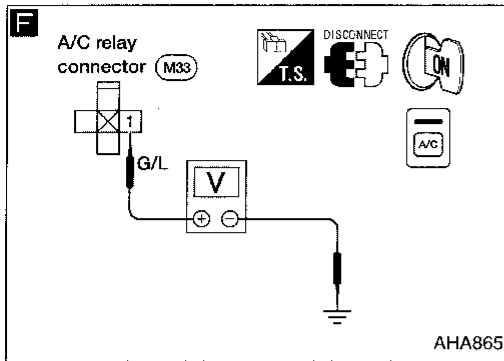

F

CHECK POWER SUPPLY FOR A/C RELAY.
Do approx. 12 volts exist between A/C relay harness terminal No. ① and body ground?

Yes → (Go to **B**) below.)

No

G

CHECK POWER SUPPLY FOR A/C SWITCH.
Disconnect A/C switch harness connector. Do approx. 12 volts exist between A/C switch harness terminal No. ② and body ground?

No → Check power supply circuit and 15A fuse (No. ③), located in the fuse block. (Refer to "POWER SUPPLY ROUTING" in EL section and Wiring Diagram.)

Yes

CHECK A/C SWITCH.
Refer to HA-41.

NG → Replace A/C switch.

OK

H Note

Check circuit continuity between A/C switch harness terminal No. ① and A/C relay harness terminal No. ①.
Continuity should exist.
If OK, check harness for short.

B

CHECK A/C RELAY AFTER DISCONNECTING IT.
Refer to HA-42.

NG → Replace A/C relay.

OK

Reconnect A/C relay.

I

CHECK COIL SIDE CIRCUIT OF A/C RELAY.
Disconnect ECM (ECCS control module) harness connector. Do approx. 12 volts exist between ECM (ECCS control module) harness terminal No. ⑮ and body ground?

No

J Note

Check circuit continuity between A/C relay harness terminal No. ② and ECM (ECCS control module) harness terminal No. ⑮.
Continuity should exist.
If OK, check harness for short.

Yes

Reconnect ECM (ECCS control module) harness connector.

C
(Go to next page.)

Note:
If the result is NG after checking circuit continuity, repair harness or connector.

TROUBLE DIAGNOSES

Diagnostic Procedure 2 (Cont'd)

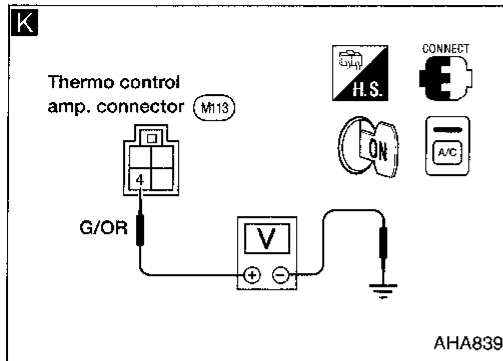

C

K

CHECK VOLTAGE FOR THERMO CONTROL AMP.

Do approx. 5 volts exist between thermo control amp. harness terminal No. ④ and body ground?

Yes → (Go to **D**) below.)

No

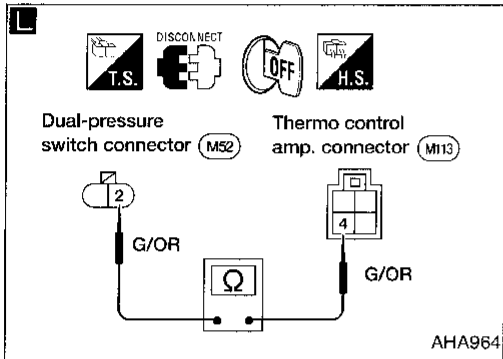

L

Check circuit continuity between thermo control amp. harness terminal No. ④ and dual-pressure switch terminal No. ②.

Continuity should exist.

If OK, check harness for short

OK

L

CHECK DUAL-PRESSURE SWITCH.

Refer to HA-41.

NG → Replace dual-pressure switch.

OK

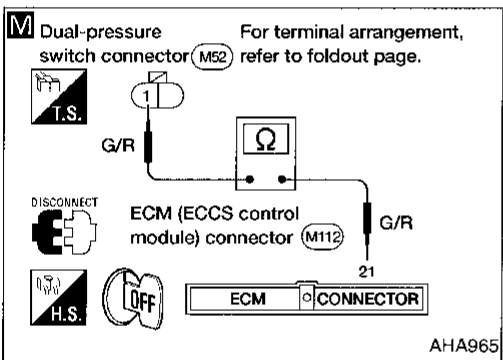

M

Check circuit continuity between ECM (ECCS control module) harness terminal No. ②① and dual-pressure switch harness terminal No. ①.

Continuity should exist.

If OK, check harness for short.

OK

M

CHECK ECM (ECCS CONTROL MODULE).

Refer to EC section.

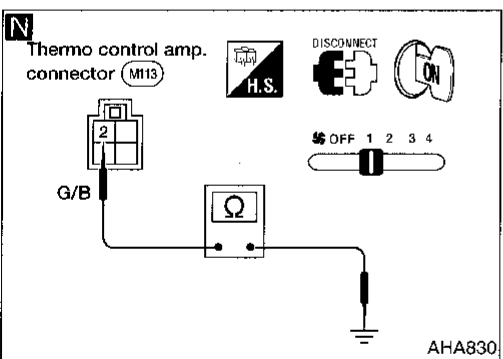

D

CHECK POWER SUPPLY FOR THERMO CONTROL AMP.

Refer to HA-33.

N

CHECK BODY GROUND CIRCUIT FOR THERMO CONTROL AMP.

Disconnect thermo control amp. harness connector.

Does continuity exist between thermo control amp. harness terminal No. ② and body ground?

Yes → Replace thermo control amp.

No

E

(Go to next page.)

Note:
If the result is NG after checking circuit continuity, repair harness or connector.

GI
MA
EM
LG
EC
FE
CL
MT
AT
TF
PD
FA
RA
BR
ST
RS
BT
HA
EL
IDX

TROUBLE DIAGNOSES

Diagnostic Procedure 2 (Cont'd)

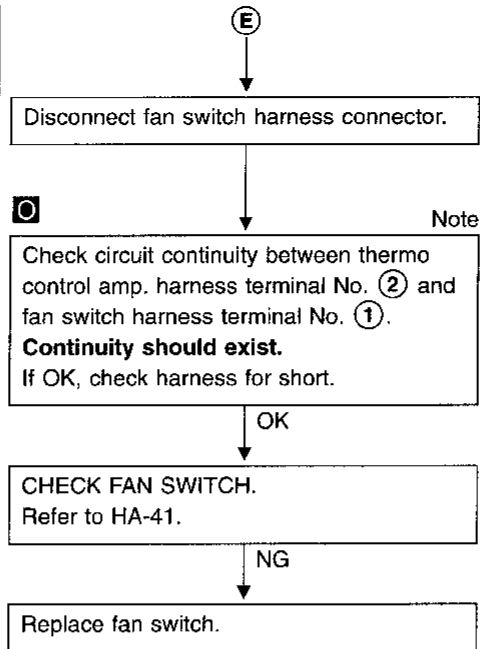
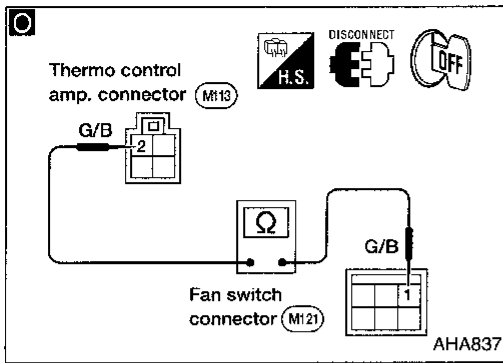

TROUBLE DIAGNOSES

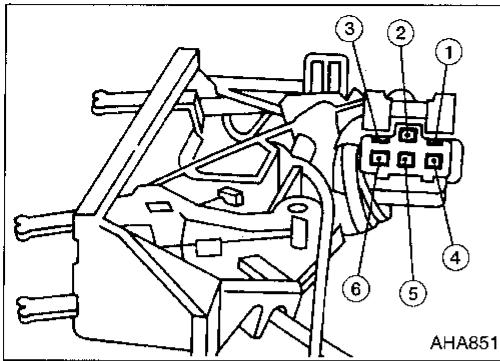

Electrical Components Inspection

FAN SWITCH

Check continuity between terminals at each lever position.

TERMINAL	LEVER POSITION	OFF	1	2	3	4
3						○
5			○			
2				○		
6			○	○	○	
4			○	○	○	○
1			○	○	○	○

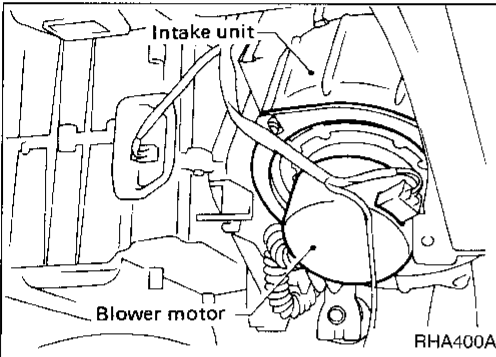

BLOWER MOTOR

Confirm smooth rotation of the blower motor.

- Check that there are no foreign particles inside the intake unit.

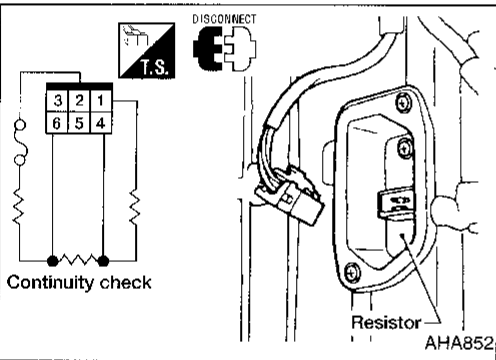

BLOWER RESISTOR

Check continuity between terminals.

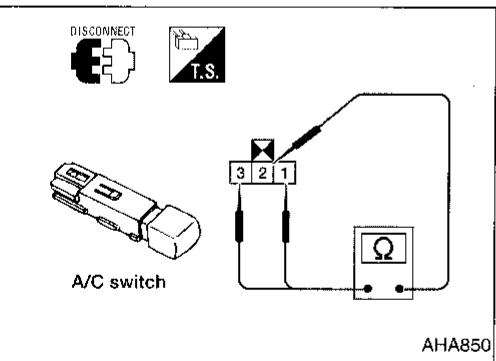

A/C SWITCH

Check continuity between terminals at each switch position.

	ON	OFF	
2	○	○	A/C indicator lamp
1	○	○	
3	○	○	

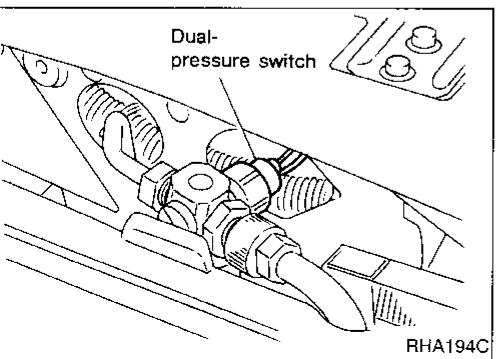

DUAL-PRESSURE SWITCH

High-pressure side line pressure kPa (kg/cm ² , psi)	Operation	Continuity
Decreasing to 157 - 216 (1.6 - 2.2, 23 - 31)	Turn OFF	Does not exist
Increasing to 2,648 - 2,844 (27 - 29, 384 - 412)		
Increasing to 157 - 235 (1.6 - 2.4, 23 - 34)	Turn ON	Exists
Decreasing to 392 - 785 (4 - 8, 57 - 114)		

GI
MA
EM
LC
EC
FE
CL
MT
AT
TF
PD
FA
RA
BR
ST
RS
BT
HA
EL
IDX

TROUBLE DIAGNOSES

Electrical Components Inspection (Cont'd)

THERMO CONTROL AMP.

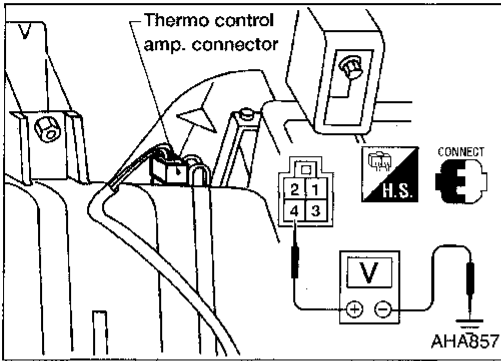

Evaporator outlet air temperature °C (°F)	Thermo amp. operation	Tester
Decreasing to 0.1 - 0.9 (32 - 34)	Turn OFF	Approx. 12V
Increasing to 2.5 - 3.5 (37 - 38)	Turn ON	Approx. 0V

THERMAL PROTECTOR

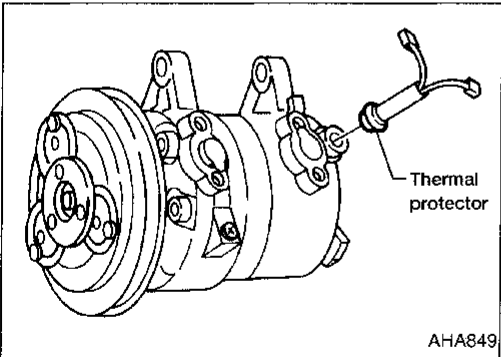

Temperature of compressor °C (°F)	Operation
Increasing to approx. 145 - 155 (293 - 311)	Turn OFF
Decreasing to approx. 130 - 140 (266 - 284)	Turn ON

A/C RELAY AND BLOWER MOTOR RELAY

Check circuit continuity between terminals by supplying 12 volts to coil side terminals of relay.

- Blower motor relay

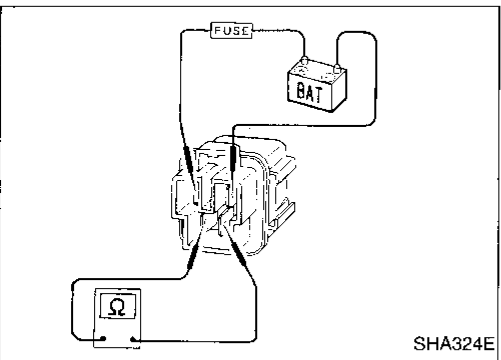

- A/C relay

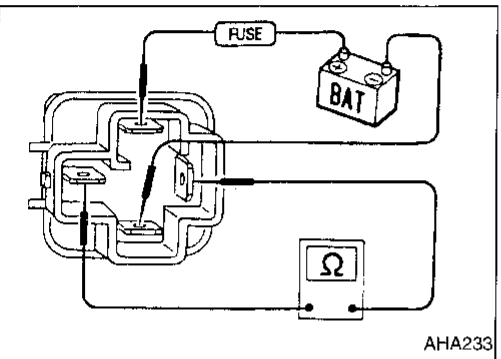

Control Linkage Adjustment

VENTILATOR DOOR CONTROL ROD

1. Move side link in direction of arrow.
2. With upper and lower ventilator door levers held in the direction of the arrow, connect rods ① and ② to their corresponding ventilator door levers in that order.

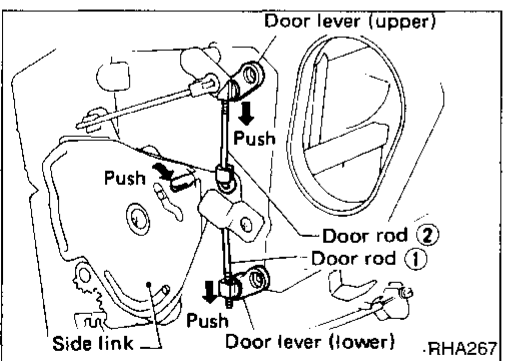

TROUBLE DIAGNOSES

Control Linkage Adjustment (Cont'd)

DEFROST DOOR CONTROL ROD

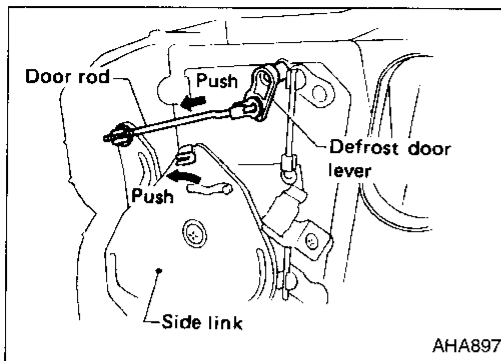

1. Move side link in direction of arrow.
2. Connect rod to side link while pushing defrost door lever in direction of arrow.

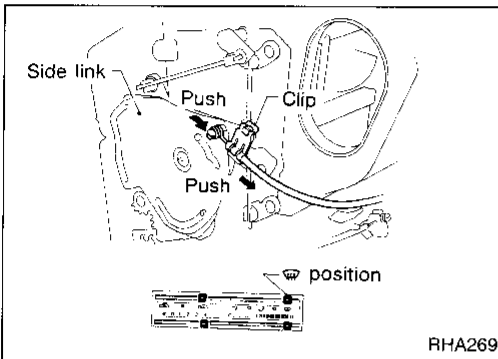

MODE CONTROL CABLE

- Move mode control lever to  position. Set side link in DEF mode. Pull on outer cable in direction of arrow and then clamp it.
- **After positioning mode control cable, check that it operates properly.**

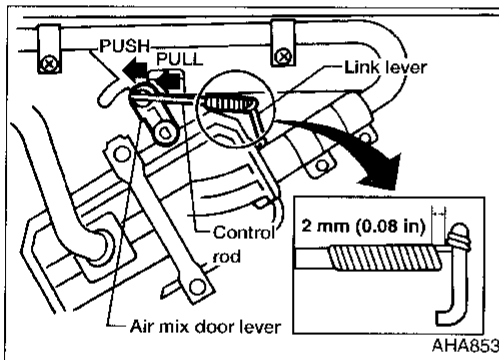

WATER COCK CONTROL ROD

- **When adjusting water cock control rod, first disconnect temperature control cable from air mix door lever and then adjust control rod. Reconnect temperature control cable and readjust it. (Refer to next item.)**
- 1. Push air mix door lever in direction of arrow.
- 2. Pull control rod of water cock in direction of arrow so as to make clearance of about 2 mm (0.08 in) between ends of rod and link lever and connect the rod to door lever.
- **After connecting water cock control rod, check that it operates properly.**

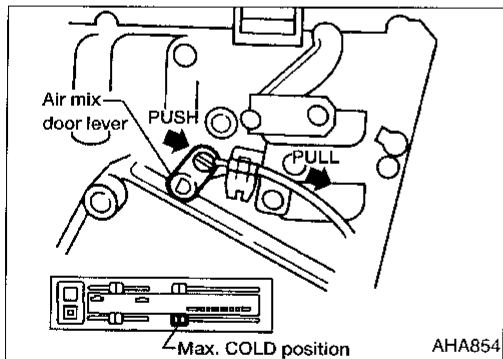

TEMPERATURE CONTROL CABLE

- **When adjusting ventilator door rod and defrost door rod, first disconnect mode control cable from side link. Reconnect and readjust mode control cable.**
- Move temperature control lever to max. COLD position. Set air mix door lever in full hot mode. Pull on outer cable in direction of arrow and then clamp it.
- **After positioning temperature control cable, check that it operates properly.**

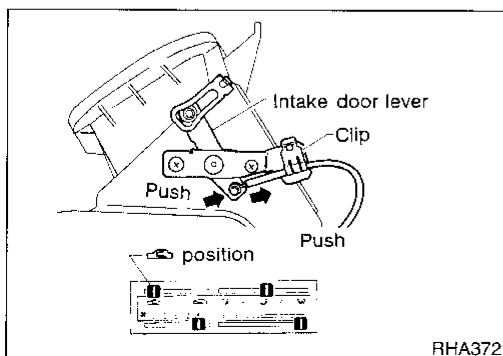

RECIRCULATION CONTROL CABLE

- Move recirculation lever to  position. Set recirculation lever in REC mode. Pull on outer cable in direction of arrow and then clamp it.
- **After positioning recirculation control cable, check that it operates properly.**

GI
MA
EM
LC
EC
FE
CL
MT
AT
TF
PD
FA
RA
BR
ST
RS
BT
HA
EL
IDX

Checking Refrigerant Leaks

PRELIMINARY CHECK

Perform a visual inspection of all refrigeration parts, fittings, hoses, and components for signs of A/C lubricant leakage, damage and corrosion.

PRECAUTIONS FOR HANDLING LEAK DETECTOR

When performing a refrigerant leak check, use a J39400 A/C leak detector or equivalent. Ensure that the instrument is calibrated and set properly per the operating instructions.

The leak detector is a delicate device. In order to use the leak detector properly, read the operating instructions and perform any specified maintenance.

Other gases in the work area or substances on the A/C components, for example, anti-freeze, windshield washer fluid, solvents and cleaners, may falsely trigger the leak detector. Make sure the surfaces to be checked are clean. Do not allow the sensor tip of the detector to come into contact with any substance. This can also cause false readings and may damage the detector.

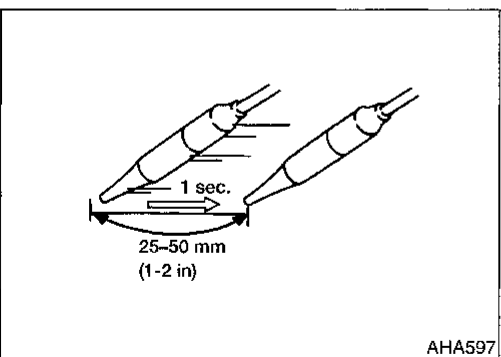
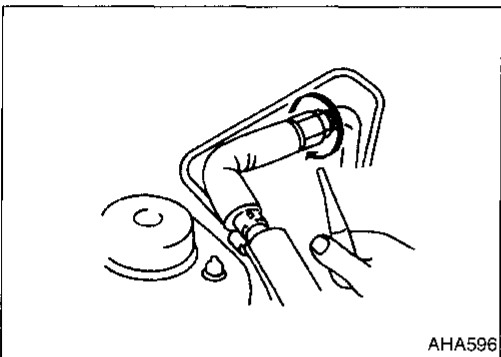
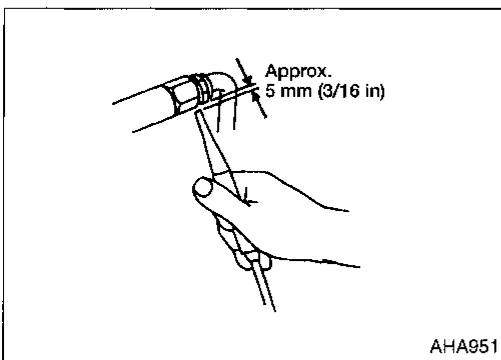
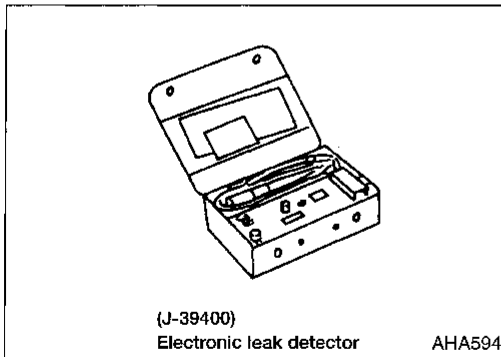

1. Position probe approximately 5 mm (3/16 in) away from point to be checked.

2. When testing, circle each fitting completely with probe.

3. Move probe along component approximately 25 - 50 mm (1-2 in)/sec.

SERVICE PROCEDURES

Checking Refrigerant Leaks (Cont'd)

CHECKING PROCEDURE

To prevent inaccurate or false readings, make sure there is no refrigerant vapor or tobacco smoke in the vicinity of the vehicle. Perform the leak test in calm area (low air/wind movement) so that the leaking refrigerant is not dispersed.

1. Turn engine off.
2. Connect a suitable A/C manifold gauge set to the A/C service ports.
3. Check if the A/C refrigerant pressure is at least 345 kPa (50 psi) above 16°C (60°F). If less than specification, evacuate and recharge the system with the specified amount of refrigerant.
NOTE: At temperatures below 16°C (60°F), leaks may not be detected since the system may not reach 345 kPa (50 psi).
4. Conduct the leak test from the high side to the low side at points ① through ①. Refer to HA-47.
Perform a leak check for the following areas carefully. Clean the component to be checked and move the leak detector probe completely around the connection/component.
 - **Compressor**
Check the fittings of high and low pressure hoses, relief valve, and shaft seal.
 - **Liquid tank**
Check the pressure switch, tube fitting, weld seams and the fusible plug mounts.
 - **Service valves**
Check all around the service valves. Ensure service valve caps are secured on the service valves (to prevent leaks).
NOTE: After removing A/C manifold gauge set from service valves, wipe any residue from valves to prevent any false readings by leak detector.
 - **Cooling unit (Evaporator)**
Turn blower fan on "High" for at least 15 seconds to dissipate any refrigerant trace in the cooling unit. Insert the leak detector probe into the drain hose immediately after stopping engine. (Keep the probe inserted for at least ten seconds.)
5. If a leak detector detects a leak, verify at least once by blowing compressed air into area of suspected leak, then repeat check.
6. Do not stop when one leak is found. Continue to check for additional leaks at all system components.

GI

MA

EM

LC

EC

FE

CL

MT

AT

TF

PD

FA

RA

BR

ST

RS

BT

HA

EL

IDX

SERVICE PROCEDURES

Checking Refrigerant Leaks (Cont'd)

7. Start engine.
8. Set the heater A/C control as follows:
 - a. A/C switch ON
 - b. Face mode
 - c. Recirculation switch ON
 - d. Max cold temperature
 - e. Fan speed high
9. Run engine at 1500 rpm for at least 2 minutes.
10. Turn engine off and perform leak check again following steps 4 through 6 on the previous page.

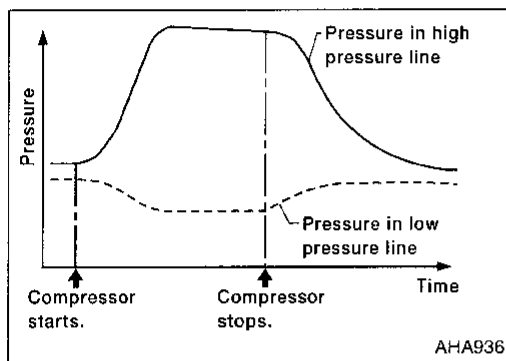

Refrigerant leaks should be checked immediately after stopping the engine. Begin with the leak detector on the high pressure line. The pressure in the high pressure line will gradually drop after refrigerant circulation stops and pressure in the low pressure line will gradually rise, as shown in the graph. Leaks are more easily detected when pressure is high.

11. Discharge A/C system using approved refrigerant recovery equipment. Repair the leaking fitting or component as necessary.
12. Evacuate and recharge A/C system and perform the leak test to confirm no refrigerant leaks.
13. Conduct A/C performance test to ensure system works properly.

Refrigerant Lines

SEC. 271•274•276

- Refer to page HA-5 regarding "Precautions for Refrigerant Connection".

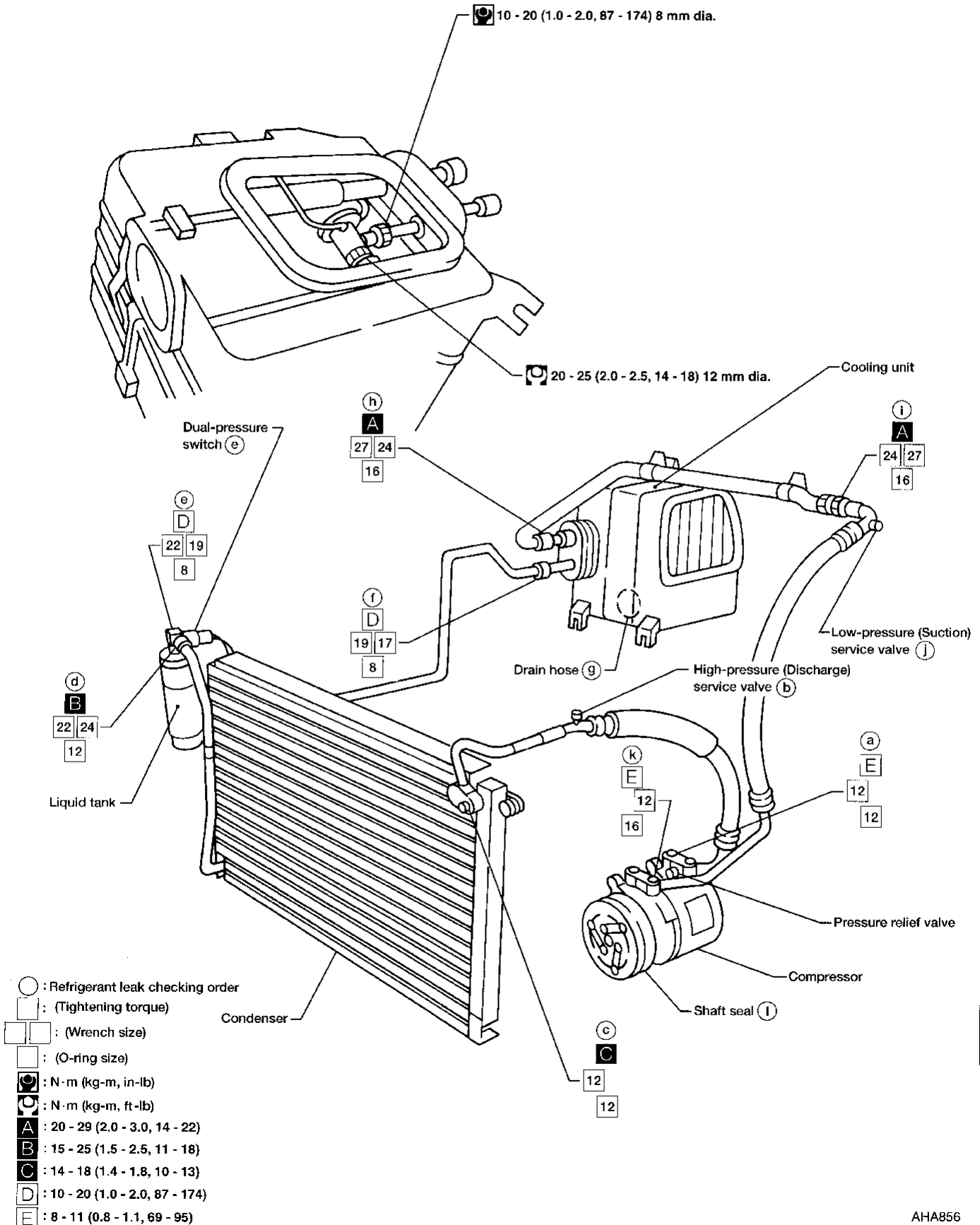

GI
MA
EM
LC
EC
FE
CL
MT
AT
TF
PD
FA
RA
BR
ST
RS
BT
HA
EL
DX

SERVICE PROCEDURES

R-134a Service Procedure

DISCHARGING REFRIGERANT

WARNING:

Avoid breathing A/C refrigerant and lubricant vapor or mist. Exposure may irritate eyes, nose and throat. Remove R-134a from A/C system, using certified service equipment meeting requirements of SAE J2210 (R-134a recycling equipment), or J2209 (R-134a recovery equipment). If accidental system discharge occurs, ventilate work area before resuming service. Additional health and safety information may be obtained from refrigerant and lubricant manufacturers.

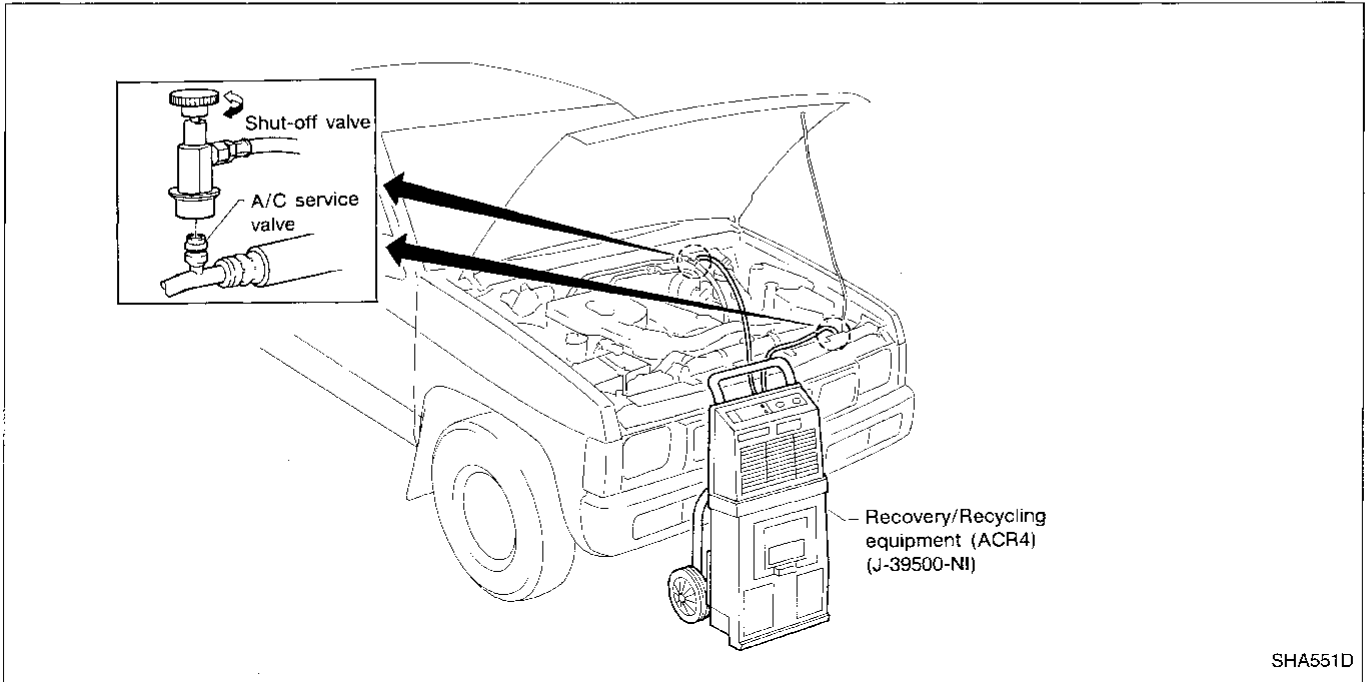

EVACUATING SYSTEM AND CHARGING REFRIGERANT

Preferred (Best) method

Alternate method

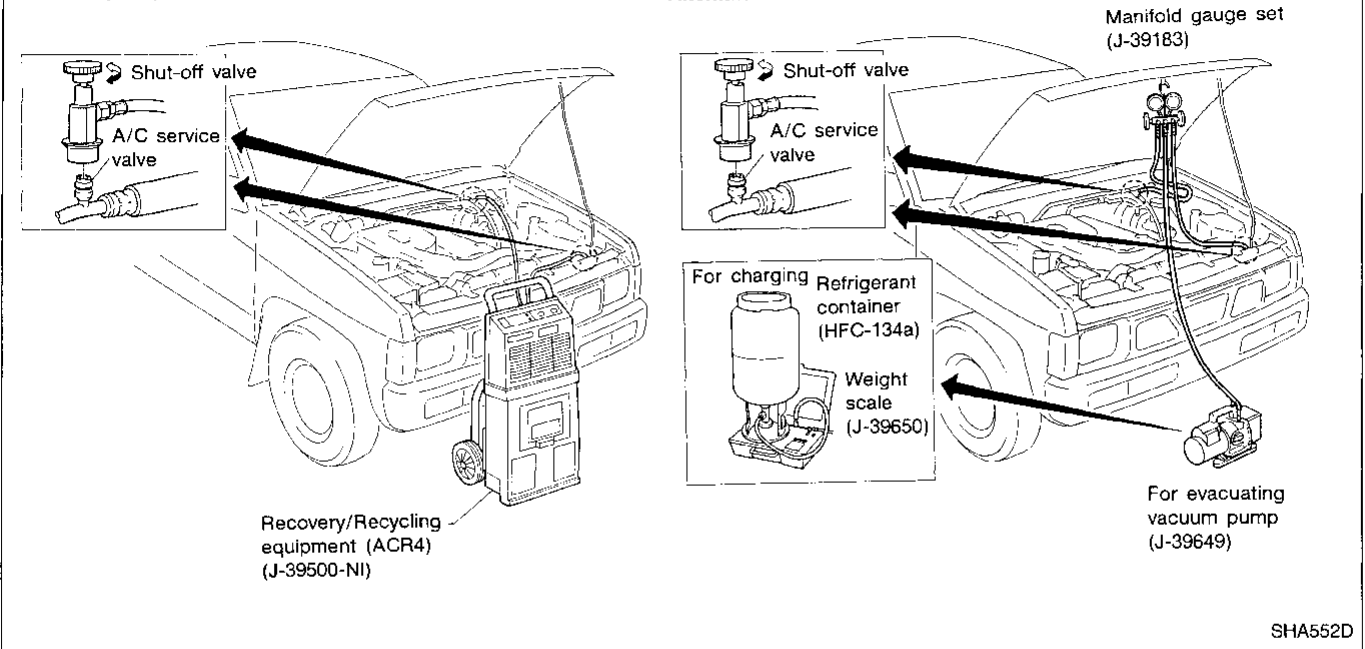

SERVICE PROCEDURES

R-134a Service Procedure (Cont'd)

Recovered lubricant. Refer to "CHECKING AND ADJUSTING", HA-50.

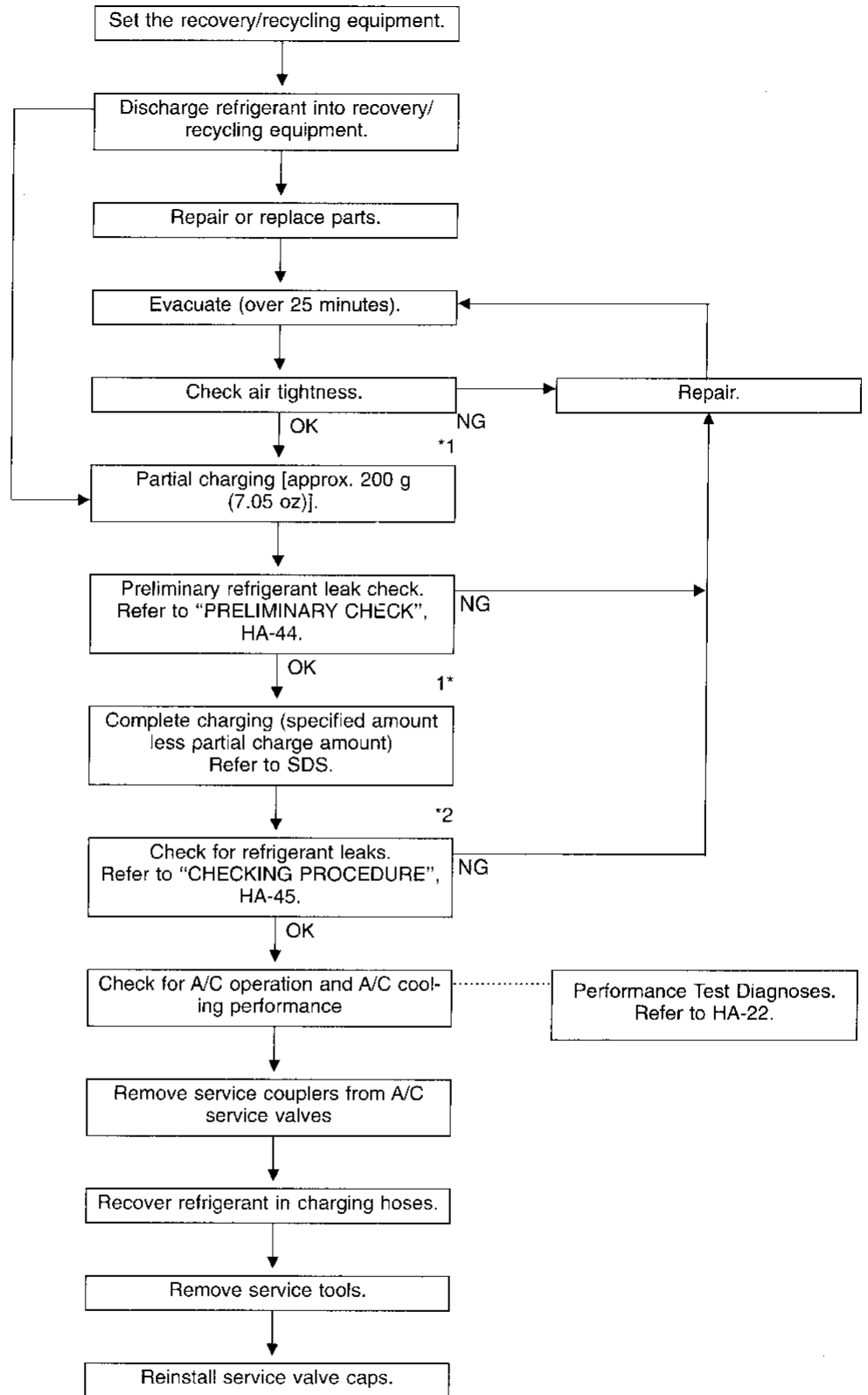

Note: *1 Before charging refrigerant, ensure engine is OFF.

*2 Before checking for leaks, start engine to activate air conditioner system then turn engine OFF. Service valve caps must be installed to prevent leakage.

Compressor Lubricant Quantity

The lubricant used to lubricate the compressor circulates through the system with the refrigerant. Whenever any A/C component is replaced or gas leakage occurs, lubricant must be added.

If lubricant quantity is not maintained properly, the following malfunctions may result:

- Lack of lubricant: May lead to a seized compressor
- Excessive lubricant: Inadequate cooling (thermal exchange interference)

LUBRICANT

Name: Nissan A/C System Lubricant Type R

Part No.: KLH00-PAGR0

CHECKING AND ADJUSTING

Adjust the lubricant quantity according to the flowchart shown below.

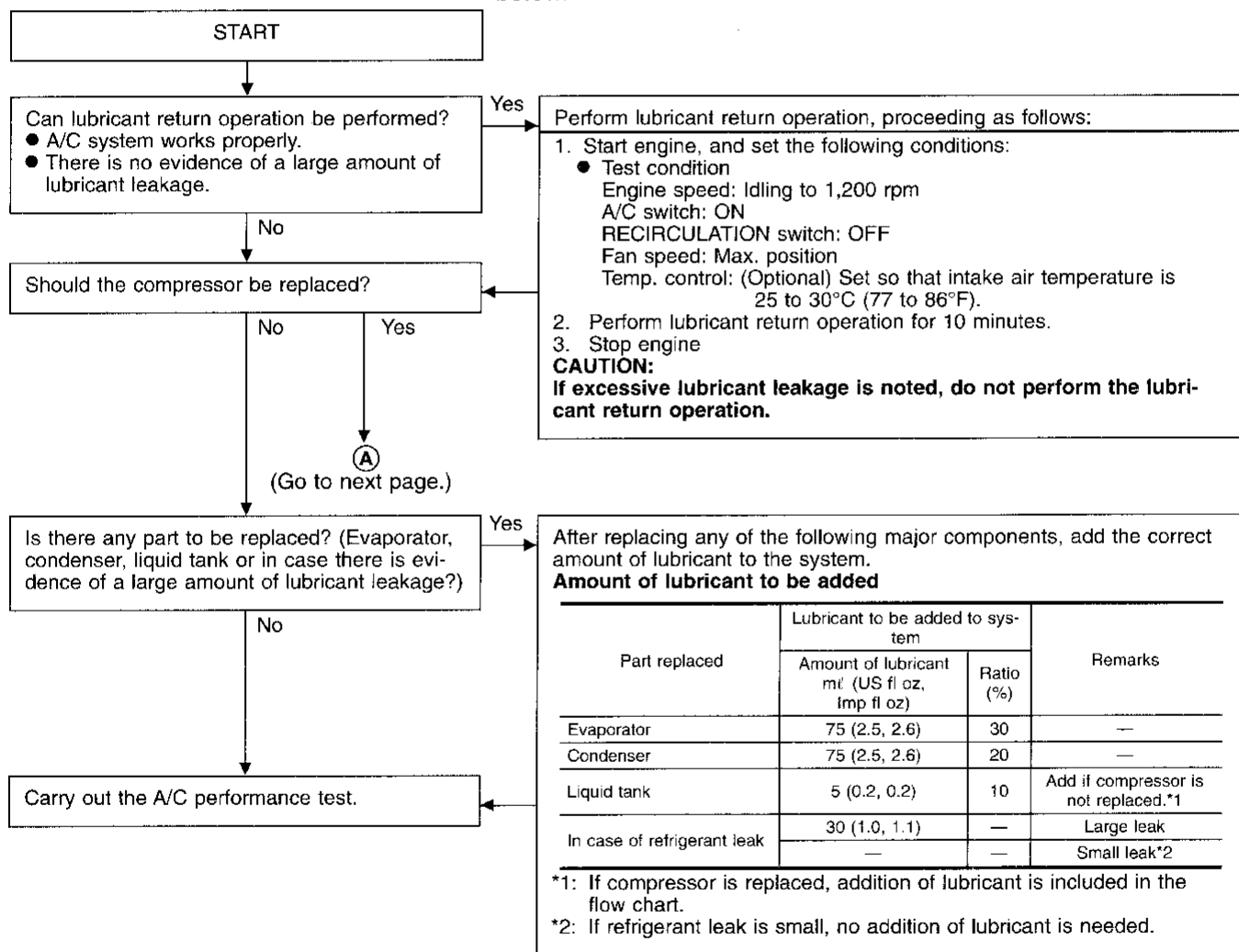

SERVICE PROCEDURES

Compressor Lubricant Quantity (Cont'd)

(A)

1. Discharge refrigerant into refrigerant recovery/recycling equipment. Measure lubricant discharged into the recovery/recycling equipment.
2. Drain the lubricant from the old (removed) compressor into a graduated container and record the amount of lubricant drained.
3. Drain the lubricant from the new compressor into a separate, clean container.
4. Measure an amount of new lubricant equal to amount drained from old compressor. Add this lubricant to new compressor through the suction port opening.
5. Measure an amount of new lubricant equal to the amount recovered during discharging. Add this lubricant to new compressor through the suction port opening.
6. If the liquid tank also needs to be replaced, add an additional 5 mℓ (0.2 US fl oz, 0.2 Imp fl oz) of lubricant at this time.
Do not add this 5 mℓ (0.2 US fl oz, 0.2 Imp fl oz) of lubricant if only replacing the compressor.

Lubricant adjusting procedure for compressor replacement

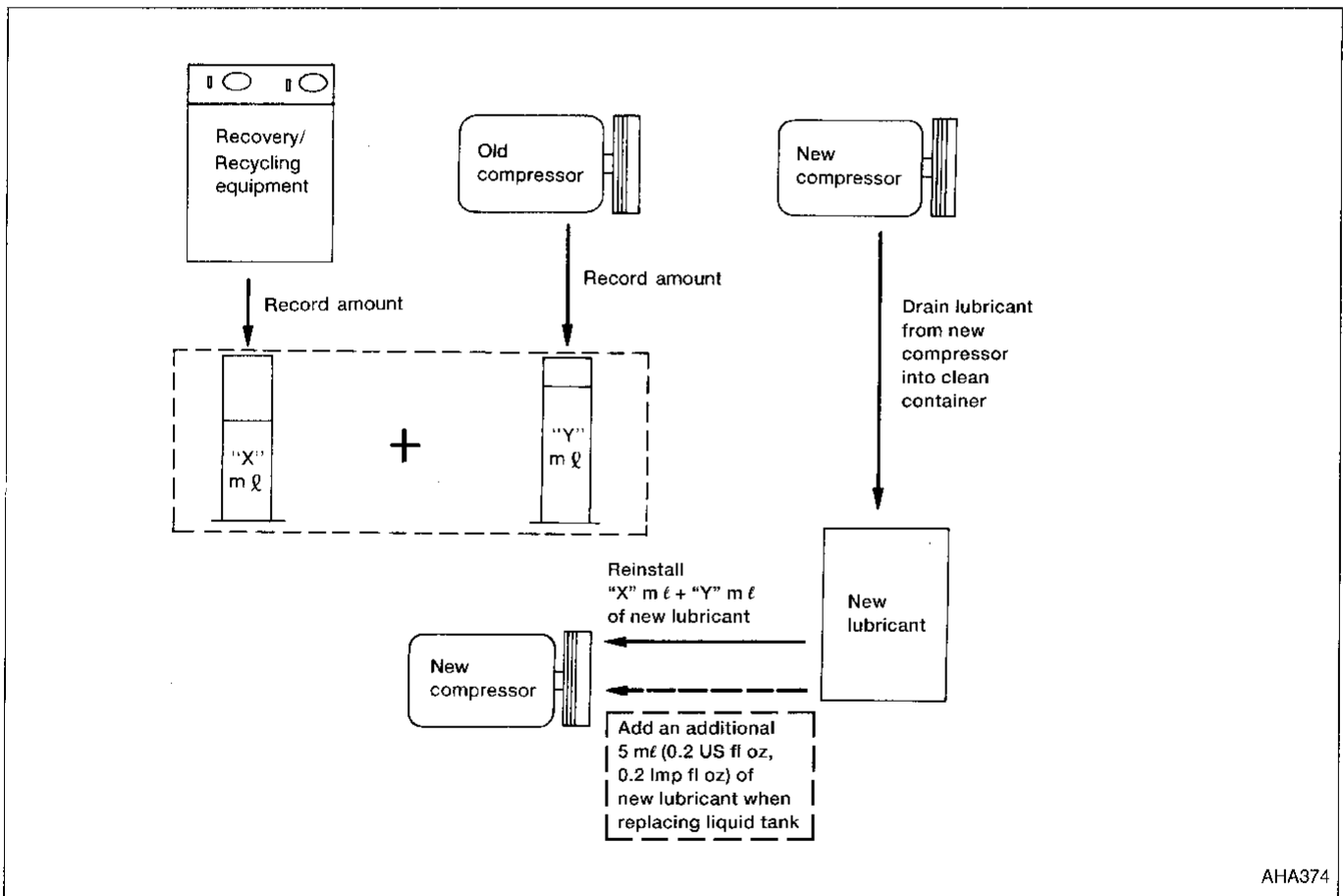

Compressor Mounting

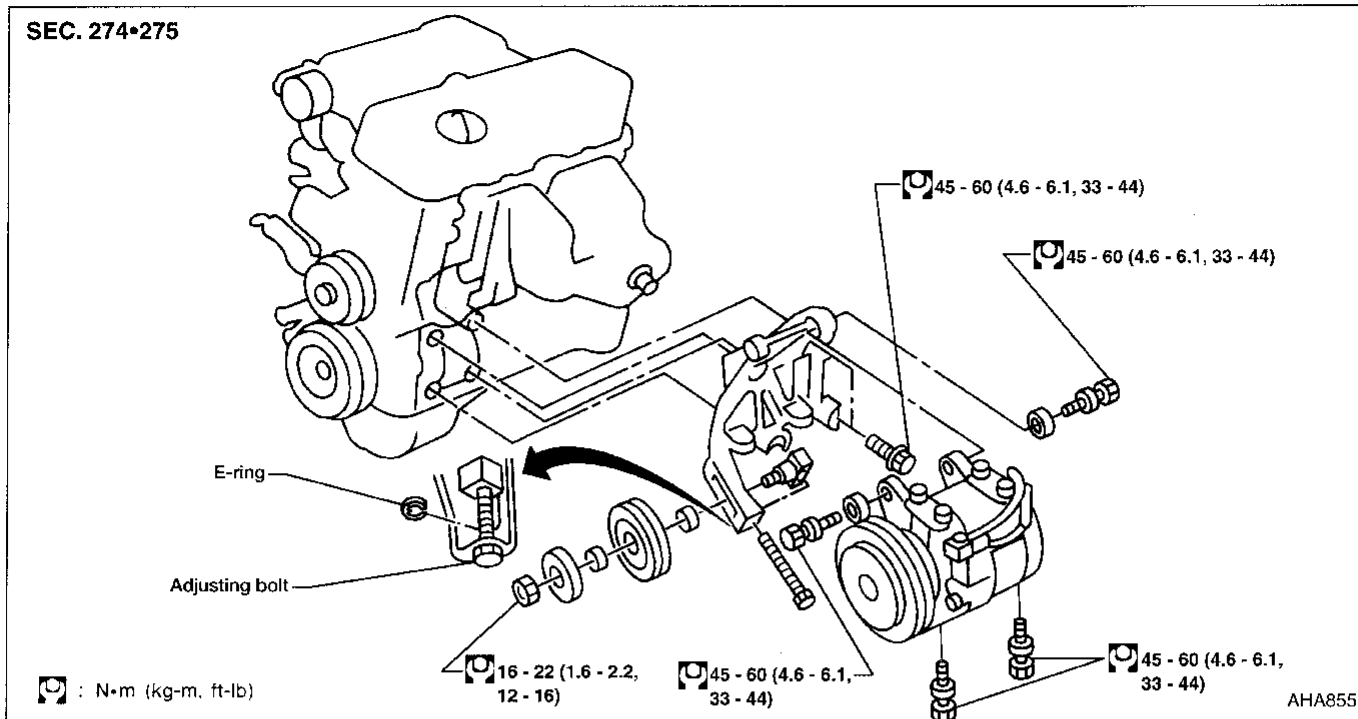

Belt Tension

- Refer to MA section ("Checking Drive Belts", "ENGINE MAINTENANCE").

Fast Idle Control Device (FICD)

- Refer to EC section ("IACV-FICD Solenoid Valve", "TROUBLE DIAGNOSIS FOR NON-DETECTABLE ITEMS").

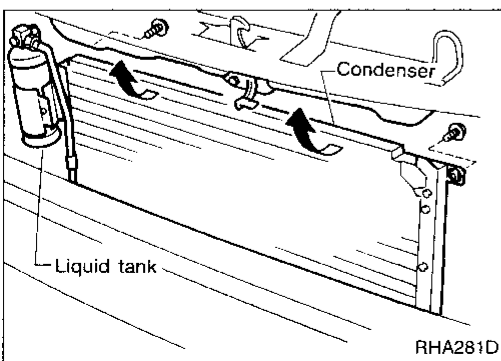
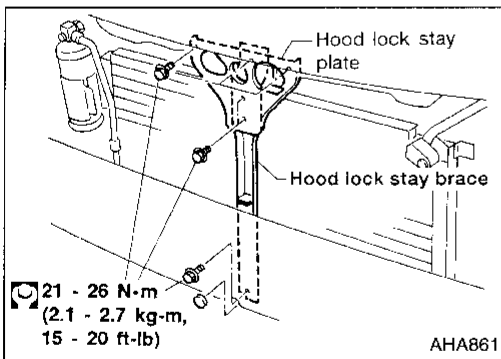

Condenser

REMOVAL

1. Discharge refrigerant using the recovery/recycling equipment (ACR4).
2. Remove coolant reservoir tank (3 screws).
3. Remove side marker lamps.
4. Remove front grille (5 fasteners).
5. Remove harness clip from hood lock stay, if equipped (gently press out).
6. Remove hood lock stay plate (4 bolts) and hood lock stay brace (2 bolts).
7. Remove hose (high-pressure) clamp bracket from radiator core support.
8. Disconnect high-pressure hose at condenser.
9. Disconnect dual-pressure switch harness connector.
10. Disconnect high-pressure tube (liquid tank to cooling unit) at liquid tank.
11. Remove condenser mounting bolts (2 bolts).
12. Remove condenser assembly.

CAUTION:

Carefully lift condenser without damaging radiator (fin and tube).

Compressor

GI
MA
EM
LC
EC
FE
CL
MT
AT
TF
PD
FA
RA
BR
ST
RS
BT
HA
EL
IDX

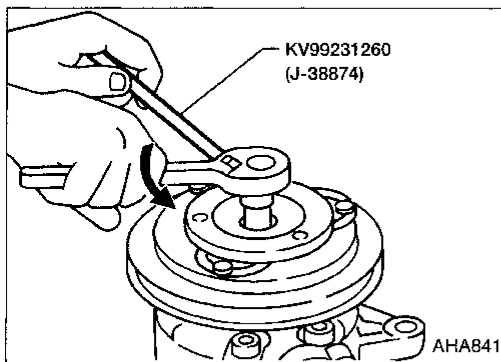
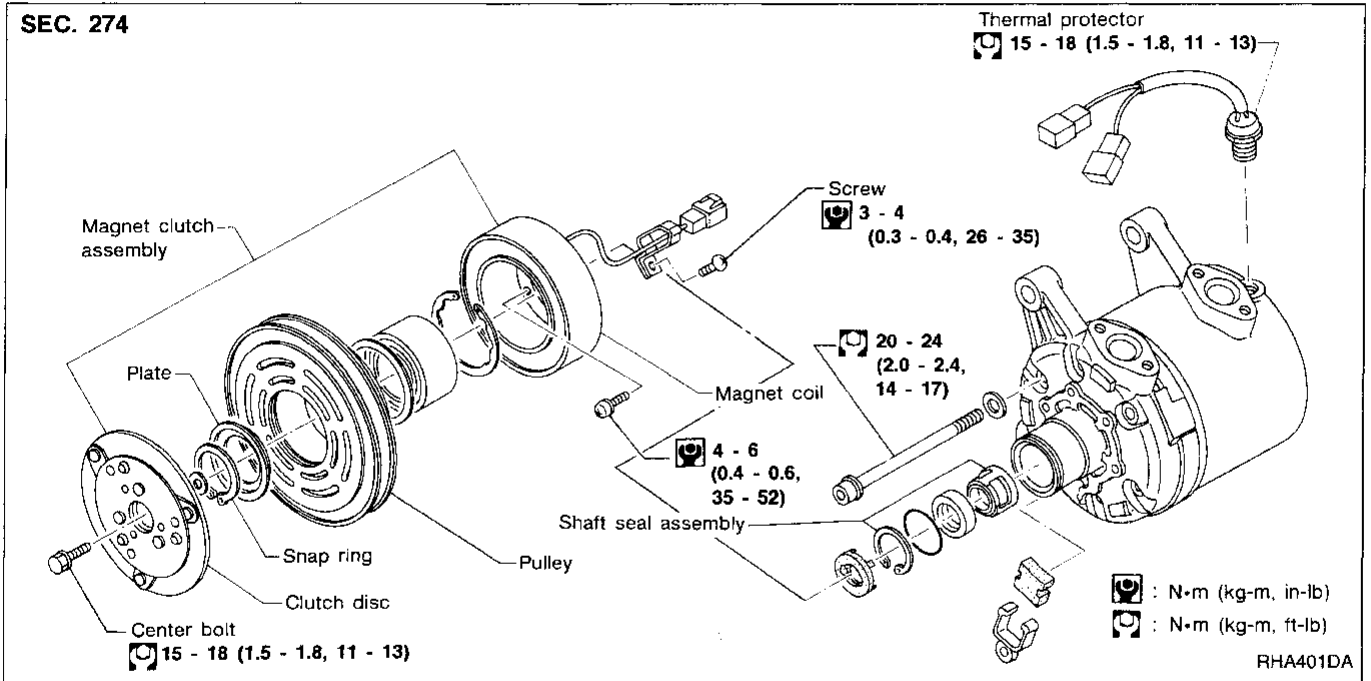

Compressor Clutch REMOVAL

- When removing center bolt, hold clutch disc with clutch disc wrench.

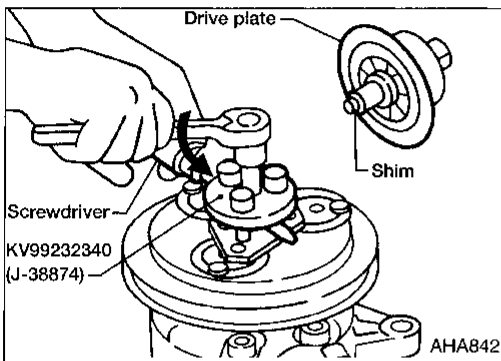

- Remove the drive plate using Tool KV99232340. Insert holder's three pins into the drive plate. Rotate the holder clockwise to hook it onto the plate. Then, tighten the center bolt to remove the drive plate. When tightening the center bolt, insert a round bar (screwdriver, etc.) between two of the pins (as shown in the left-hand figure) to prevent drive plate rotation. After removing the drive plate, remove the shims from either the drive shaft or the drive plate.

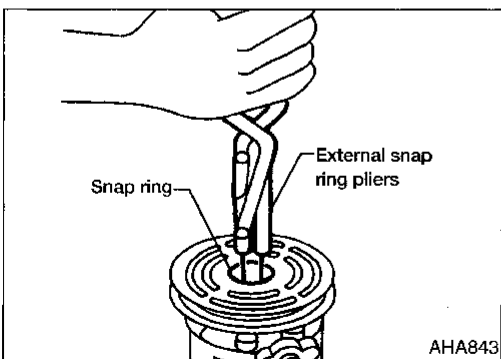

- Remove the snap ring using external snap ring pliers.

SERVICE PROCEDURES

Compressor Clutch (Cont'd)

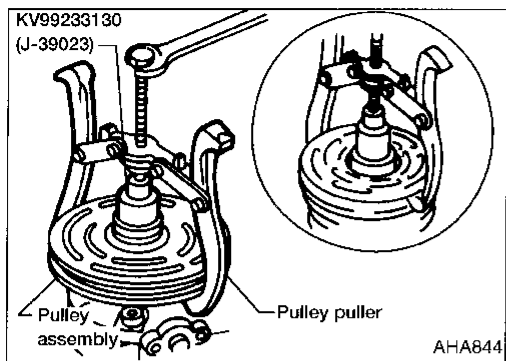

- Pulley removal
Use any commercially available pulley puller. Position the center of it on the end of the drive shaft, and remove the pulley assembly.

For pressed pulleys:

To prevent deformation of the pulley groove, the puller claws should be hooked under (not into) the pulley groove.

For machine latched pulleys:

Align the pulley puller groove with the pulley groove, and then remove the pulley assembly.

- Remove the field coil harness clip using a screwdriver.

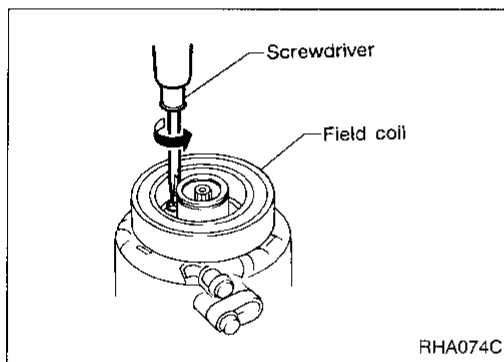

- Remove the three field coil fixing screws and remove the field coil.

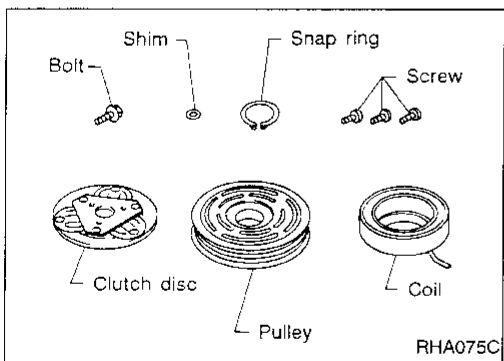

INSPECTION

Clutch disc : If the contact surface shows signs of damage due to excessive heat, replace clutch disc and pulley.

Pulley : Check the appearance of the pulley assembly. Check the contact surface of the pulley for any sign of excessive grooving due to slippage. If any sign is found, replace both the pulley and clutch disc. The contact surfaces of the pulley assembly should be cleaned with a suitable solvent before reinstallation.

Coil : Check coil for loose connection or cracked insulation.

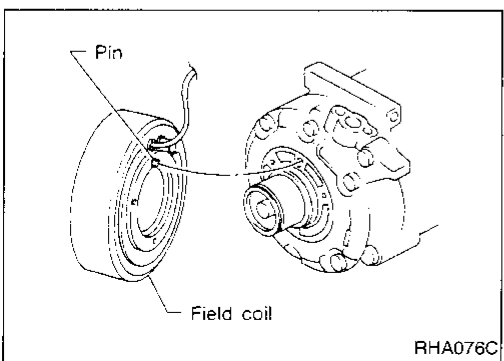

INSTALLATION

- Install the field coil.
- **Be sure to align the coil's pin with the hole in the compressor's front head.**
- Install the field coil harness clip using a screwdriver.

SERVICE PROCEDURES

Compressor Clutch (Cont'd)

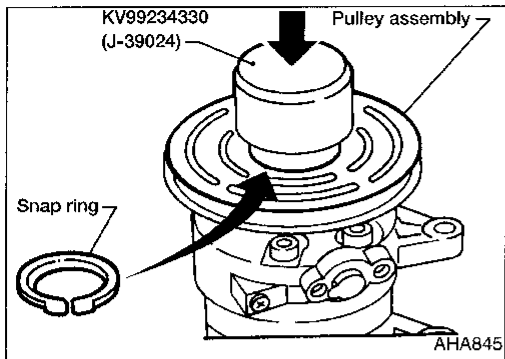

- Install the pulley assembly using the installer and a hand press, and then install the snap ring using snap ring pliers.

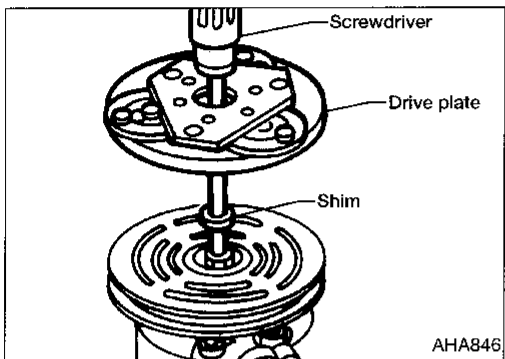

- Install the drive plate on the drive shaft, together with the original shim(s). Press the drive plate down by hand.

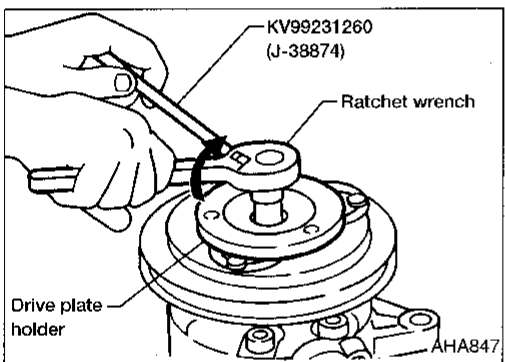

- Using the holder to prevent drive plate rotation, tighten the bolt to 12 - 15 N·m (1.2 - 1.5 kg-m, 9 - 11 ft-lb) torque.
- **After tightening the bolt, check that the pulley rotates smoothly.**

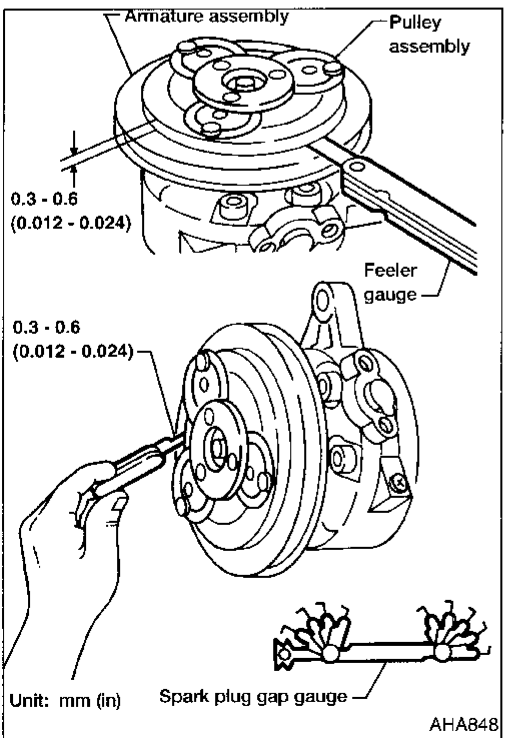

- Check clearance around the entire periphery of clutch disc.
Disc-to-pulley clearance:
0.3 - 0.6 mm (0.012 - 0.024 in)
 If the specified clearance is not obtained, replace adjusting spacer and readjust.

BREAK-IN OPERATION

When replacing compressor clutch assembly, always conduct the break-in operation. This is done by engaging and disengaging the clutch about thirty times. Break-in operation raises the level of transmitted torque.

GI
MA
EM
LC
EC
FE
CL
MT
AT
TF
PD
FA
RA
BR
ST
RS
BT
HA
EL
IDX

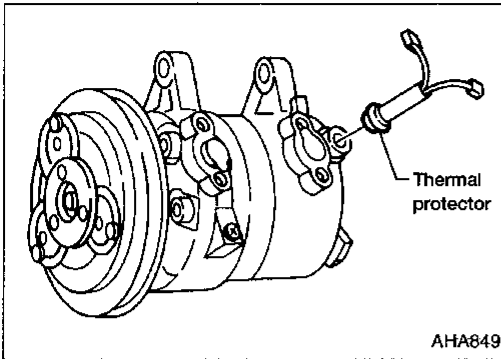

Thermal Protector

INSPECTION

- When servicing, do not allow foreign matter to get into compressor.
- Check continuity between two terminals.

SERVICE DATA AND SPECIFICATIONS (SDS)

General Specifications

COMPRESSOR

Model	DKV-14C
Type	Vane rotary
Displacement cm ³ (cu in)/Rev	140 (8.54)
Direction of rotation	Clockwise (Viewed from drive end)
Drive belt	A type

LUBRICANT

Model	ZEXEL make DKV-14C
Name	Nissan A/C System Oil Type R
Part number	KLH00-PAGR0
Capacity ml (US fl oz, Imp fl oz)	
Total in system	200 (6.8, 7.0)
Compressor (Service parts) charging amount	200 (6.8, 7.0)

REFRIGERANT

Type	R134a
Capacity kg (lb)	0.75 - 0.85 (1.65 - 1.87)

Inspection and Adjustment

ENGINE IDLING SPEED

When A/C is ON
Refer to EC section.

BELT TENSION

Refer to MA section ("Checking Drive Belts",
"ENGINE MAINTENANCE").

COMPRESSOR

Model	DKV-14C
Clutch disc-to-pulley clearance mm (in)	0.3 - 0.6 (0.012 - 0.024)

GI

MA

EM

LC

EC

FE

CL

MT

AT

TF

PD

FA

RA

BR

ST

RS

BT

HA

EL

IDX