

FRONT AXLE & FRONT SUSPENSION

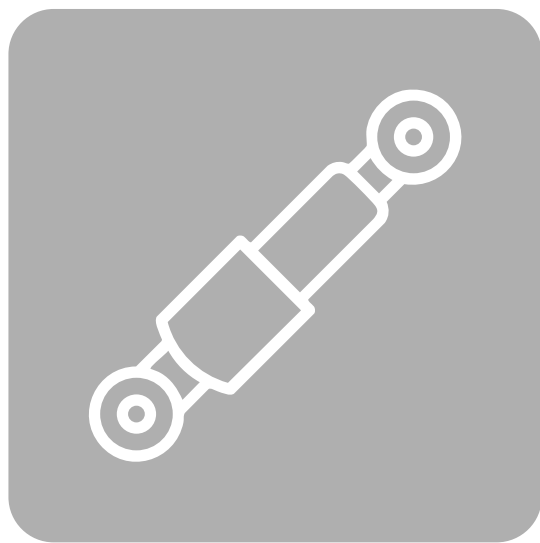

FRONT AXLE & FRONT SUSPENSION

SECTION **FA**

CONTENTS

| | | | |
|--|----|--|----|
| PRECAUTIONS AND PREPARATION | 2 | FRONT AXLE | 15 |
| Precautions | 2 | FRONT AXLE (4WD) | 17 |
| Special Service Tools | 2 | Manual-lock Free-running Hub | 17 |
| Commercial Service Tools | 2 | Auto-lock Free-running Hub | 18 |
| FRONT AXLE AND FRONT SUSPENSION | 3 | FRONT AXLE | 24 |
| ON-VEHICLE SERVICE | 5 | Wheel Hub and Rotor Disc..... | 24 |
| Front Axle and Front Suspension Parts | 5 | Knuckle Spindle..... | 25 |
| Front Wheel Bearing..... | 6 | FRONT AXLE (4WD) | 28 |
| Preload Adjustment (2WD) | 6 | Drive Shaft..... | 28 |
| Preload Adjustment (4WD) | 7 | FRONT SUSPENSION | 34 |
| Front Wheel Alignment | 8 | Shock Absorber | 36 |
| Preliminary Inspection..... | 8 | Torsion Bar Spring | 36 |
| Camber, Caster And Kingpin Inclination | 9 | Stabilizer Bar | 39 |
| Adjustment | 9 | Upper Link | 40 |
| Toe-In | 12 | Tension Rod or Compression Rod | 42 |
| Front Wheel Turning Angle | 13 | Lower Link | 43 |
| Drive Shaft..... | 14 | Upper Ball Joint and Lower Ball Joint..... | 44 |
| | | SERVICE DATA AND SPECIFICATIONS (SDS) | 45 |
| | | General Specifications..... | 45 |
| | | Inspection and Adjustment | 46 |

GI
MA
EM
LC
EC
FE
CL
MT
AT
TF
PD
FA
RA
BR
ST
RS
BT
HA
EL
IDX

FA

PRECAUTIONS AND PREPARATION

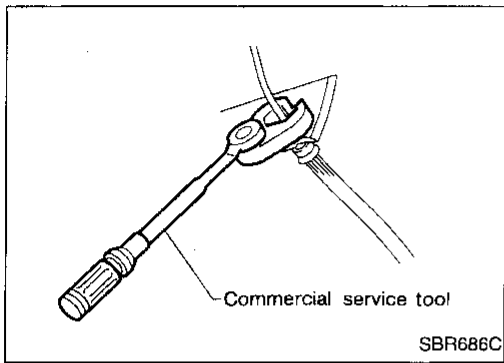

Precautions

- When installing rubber parts, final tightening must be carried out under unladen condition* with tires on ground.
- * Fuel, radiator coolant and engine oil full. Spare tire, jack, hand tools and mats in designated positions.
- Use flare nut wrench when removing or installing brake tubes.
- After installing removed suspension parts, check wheel alignment and adjust if necessary.
- Always torque brake lines when installing.

Special Service Tools

The actual shapes of Kent-Moore tools may differ from those of special service tools illustrated here.

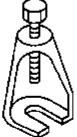
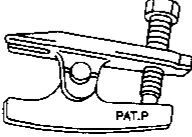
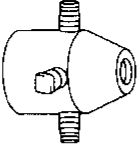
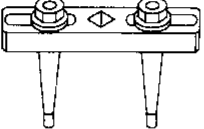
| Tool number (Kent-Moore No.) Tool name | Description | Unit application | | |
|---|--|---|-----|---|
| | | 2WD | 4WD | |
| ST29020001 (J24319-01) Gear arm puller |  NT143 | Removing ball joint for knuckle spindle | X | X |
| HT72520000 (J25730-B) Ball joint remover |  NT146 | Removing tie-rod outer end | X | X |
| KV401021S0 (—) Bearing race drift |  NT153 | Installing wheel bearing outer race | X | X |
| KV40105400 (J36001) Wheel bearing lock nut wrench |  NT154 | Removing or installing wheel bearing lock nut | — | X |

Commercial Service Tools

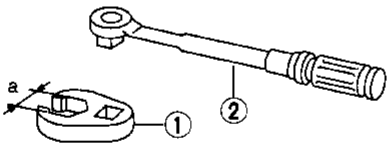
| Tool name | Description |
|---|--|
| ① Flare nut crowfoot ② Torque wrench |  NT360 a: 10 mm (0.39 in) |

FRONT AXLE AND FRONT SUSPENSION

2WD

SEC. 400-401-406

When installing rubber parts, final tightening must be carried out under unladen condition* with tires on ground.

* Fuel, radiator coolant and engine oil full.
Spare tire, jack, hand tools and mats in designated positions.

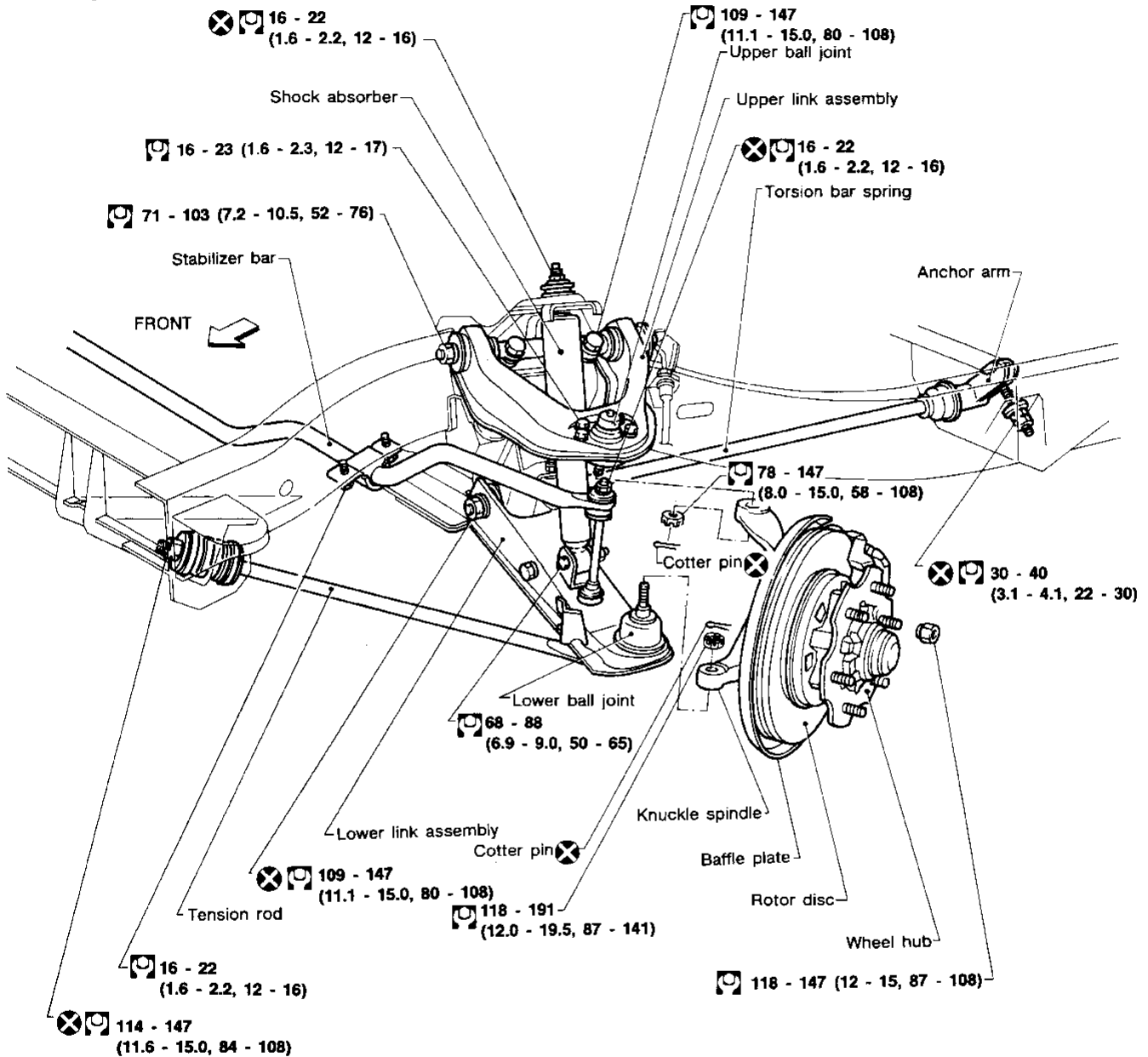

: N·m (kg·m, ft·lb)

GI
MA
EM
LC
EC
FE
CL
MT
AT
TF
PD
FA
RA
BR
ST
RS
BT
HA
EL
IDX

FRONT AXLE AND FRONT SUSPENSION

4WD

SEC. 390-400-401-406

When installing rubber parts, final tightening must be carried out under unladen condition* with tires on ground.

* Fuel, radiator coolant and engine oil full.
Spare tire, jack, hand tools and mats in designated positions.

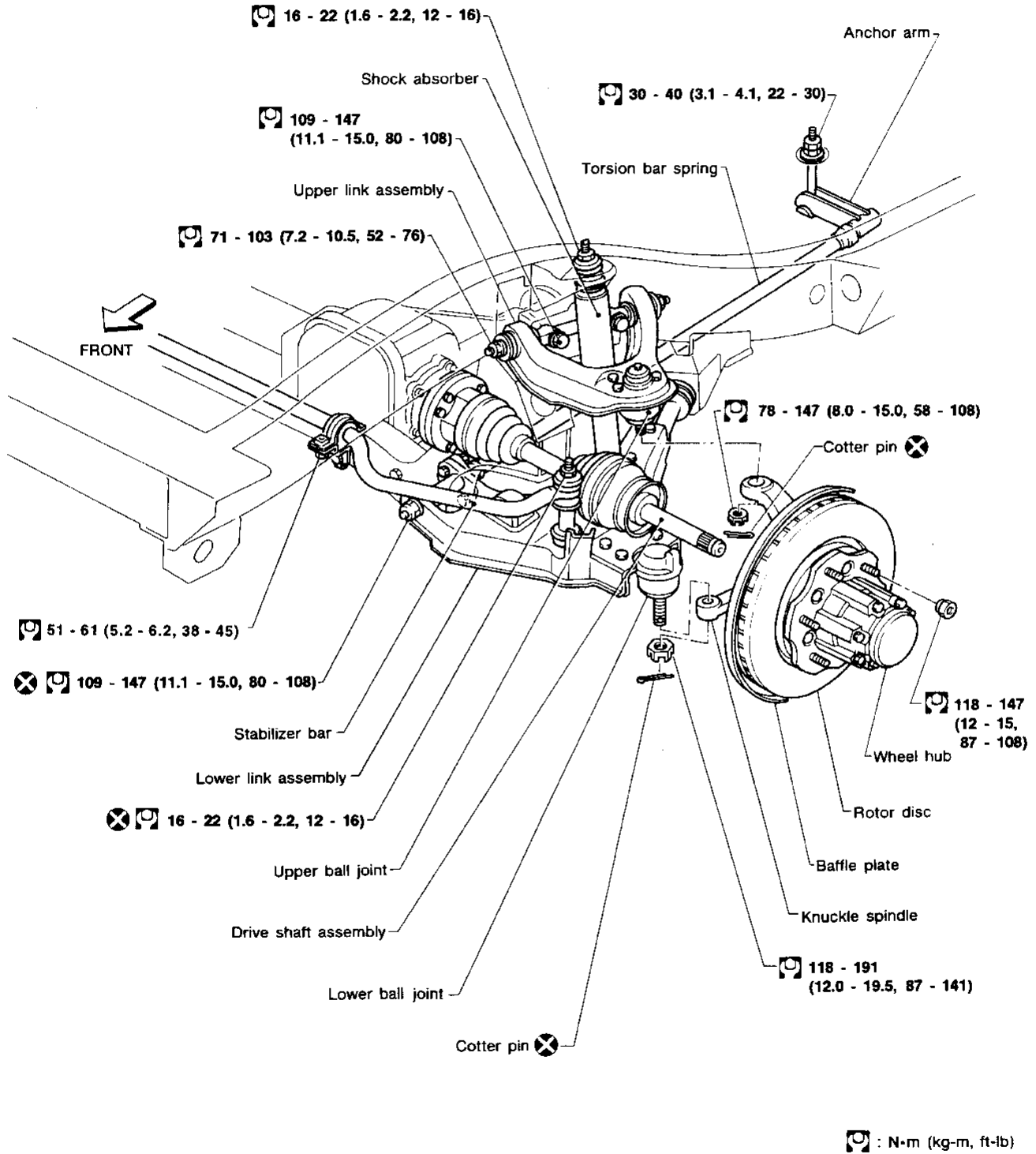

AFA097

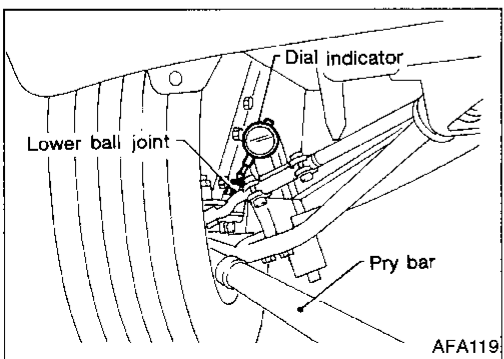
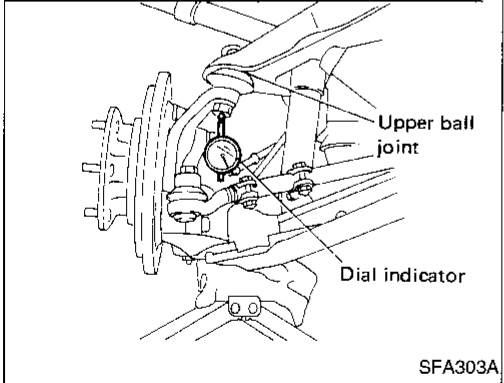
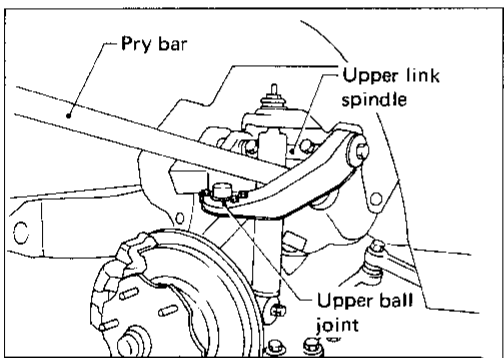
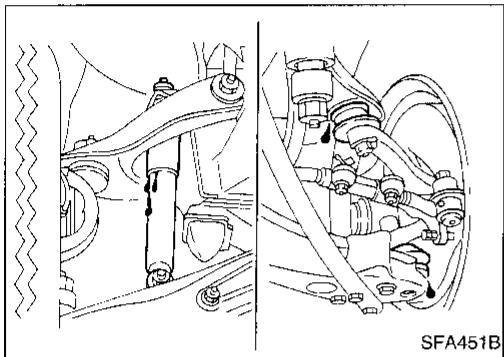
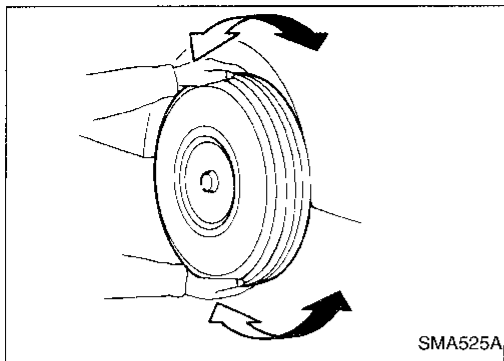

Front Axle and Front Suspension Parts

- Check front axle and front suspension parts for excessive play, cracks, wear or other damage.
 - a. Shake each front wheel to check for excessive play.
 - If looseness is noted, adjust wheel bearing end play, then check ball joint end play.
 - b. Make sure that the cotter pin is inserted.
 - c. Retighten all nuts and bolts to the specified torque.
 - ⓘ: Refer to **FRONT SUSPENSION, FA-34.**
 - d. Check front axle and front suspension parts for wear, cracks or other damage.

- Check shock absorber for oil leakage and other damage.
- Check suspension ball joint for grease leakage and ball joint dust cover for cracks and other damage.

- Check ball joint for vertical end play.

Upper ball joint:

0.1 - 1.4 mm (0.004 - 0.055 in) at side frame.

- a. Jack up front of vehicle and set the stands.
- b. Remove road wheel.
- c. Clamp dial indicator onto upper link and place indicator tip on knuckle near upper ball joint.
- d. Jack up lower link [Approx. 20 mm (0.79 in).]
- e. Place a pry bar between upper link and upper link spindle.
- f. While pushing and releasing pry bar, observe maximum dial indicator value.
- g. If upper ball joint movement is beyond specifications, remove and recheck it. Refer to "Upper Ball Joint and Lower Ball Joint", "FRONT SUSPENSION", FA-44.

Lower ball joint:

2WD

0.1 - 1.3 mm (0.004 - 0.051 in)

4WD

0.7 mm (0.028 in) or less

- a. Jack up front of vehicle and set the stands at side frame.
- b. Clamp dial indicator onto transverse link and place indicator tip on lower edge of brake caliper.
- c. Make sure front wheels are straight and brake pedal is depressed.
- d. Place a pry bar between transverse link and inner rim of road wheel.
- e. While pushing and releasing pry bar, observe maximum dial indicator value.
- f. If lower ball joint movement is beyond specifications, remove and recheck it. Refer to "Upper Ball Joint and Lower Ball Joint", "FRONT SUSPENSION", FA-44.

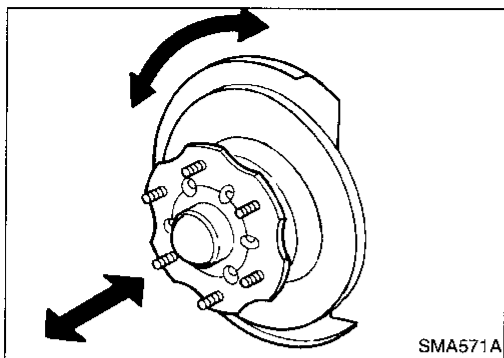

Front Wheel Bearing

- Check that wheel bearings operate smoothly.
- Check axial end play.
Axial end play: 0 mm (0 in)
- Adjust wheel bearing preload if there is any axial end play or wheel bearing does not turn smoothly.

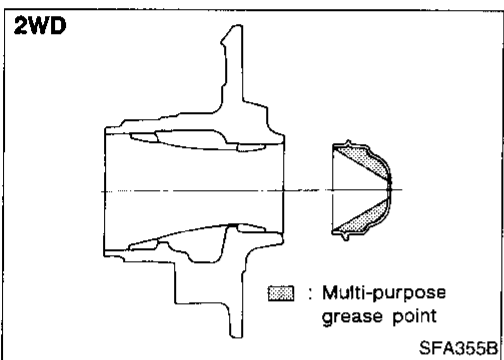

PRELOAD ADJUSTMENT (2WD)

Adjust wheel bearing preload after wheel bearing has been replaced or front axle has been reassembled.

1. Before adjustment, thoroughly clean all parts to prevent dirt entry.
2. Apply multi-purpose grease sparingly to the following parts:
 - Rubbing surface of spindle
 - Contact surface between lock washer and outer wheel bearing
 - Hub cap (as shown at left)
 - Grease seal lip

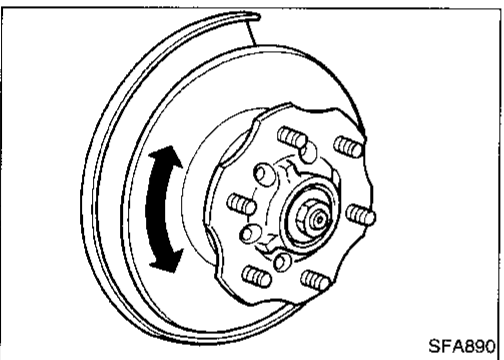

3. Tighten wheel bearing lock nut to the specified torque.
[Torque symbol]: **34 - 39 N·m (3.5 - 4.0 kg-m, 25 - 29 ft-lb)**
4. Turn wheel hub several times in both directions to seat wheel bearing correctly.
5. Again tighten wheel bearing lock nut to the specified torque.
[Torque symbol]: **34 - 39 N·m (3.5 - 4.0 kg-m, 25 - 29 ft-lb)**

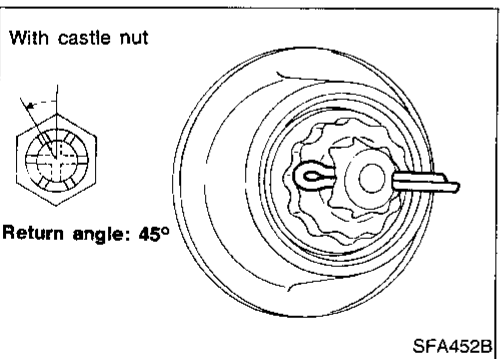

6. Turn wheel bearing lock nut back 45 degrees.
7. Fit adjusting cap and new cotter pin. Align cotter pin slot by loosening nut 15 degrees or less.

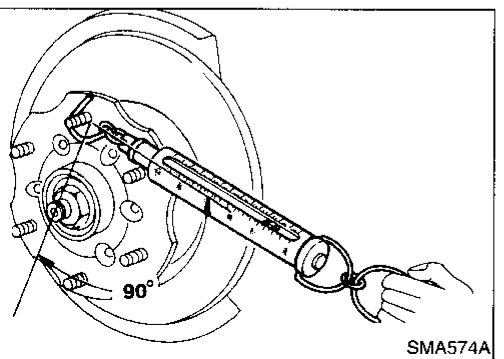

8. Measure wheel bearing preload and axial end play.
Axial end play: 0 mm (0 in)
Wheel bearing preload
(As measured at wheel hub bolt):
[New grease seal]
9.8 - 28.4 N (1.0 - 2.9 kg, 2.2 - 6.4 lb)
[Used grease seal]
9.8 - 23.5 N (1.0 - 2.4 kg, 2.2 - 5.3 lb)

Repeat above procedures until correct bearing preload is obtained.

ON-VEHICLE SERVICE

Front Wheel Bearing (Cont'd)

9. Spread cotter pin.
10. Install hub cap.

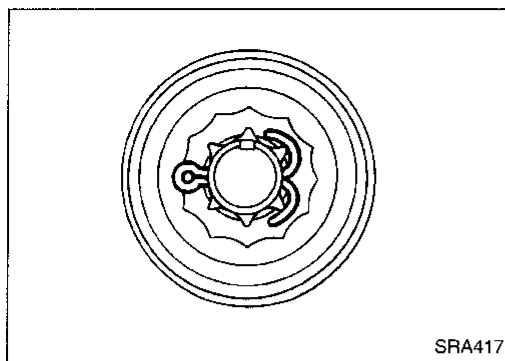

PRELOAD ADJUSTMENT (4WD)

Adjust wheel bearing preload after wheel bearing has been replaced or front axle has been reassembled.

Adjust wheel bearing preload as follows:

1. Before adjustment, thoroughly clean all parts to prevent dirt entry.

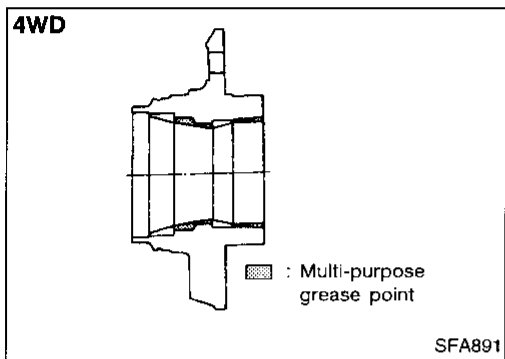

2. Apply multi-purpose grease sparingly to the following parts:
 - Threaded portion of spindle
 - Contact surface between wheel bearing washer and outer wheel bearing
 - Grease seal lip
 - Wheel hub (as shown at left)

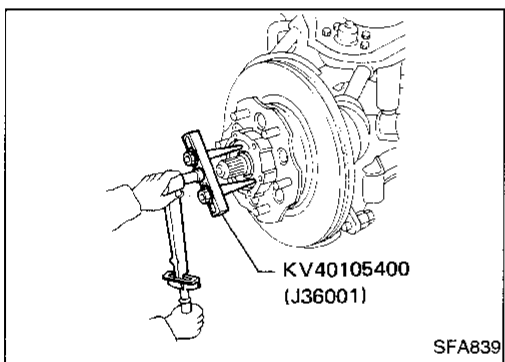

3. Tighten wheel bearing lock nut with Tool.
 ☞: **78 - 98 N·m (8 - 10 kg-m, 58 - 72 ft-lb)**
4. Turn wheel hub several times in both directions.
5. Loosen wheel bearing lock nut so that torque becomes 0 N·m (0 kg-m, 0 ft-lb).
6. Retighten wheel bearing lock nut with Tool.
 ☞: **0.5 - 1.5 N·m (0.05 - 0.15 kg-m, 4.3 - 13.0 in-lb)**

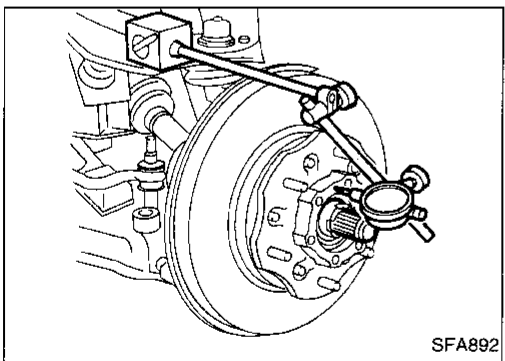

7. Turn wheel hub several times in both directions.
8. Retighten wheel bearing lock nut with Tool.
 ☞: **0.5 - 1.5 N·m (0.05 - 0.15 kg-m, 4.3 - 13.0 in-lb)**
9. Measure wheel bearing axial end play.
Axial end play: 0 mm (0 in)

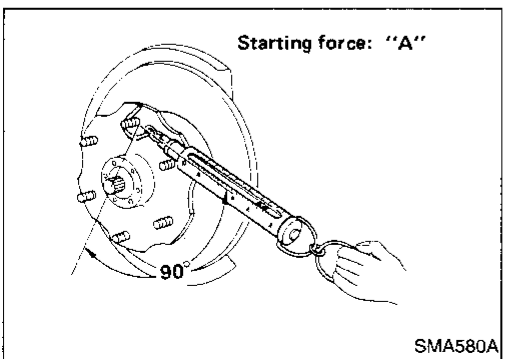

10. Measure starting force "A" at wheel hub bolt.

GI
MA
EM
LC
EC
FE
CL
MT
AT
TF
PD
FA
RA
BR
ST
RS
BT
HA
EL
IDX

ON-VEHICLE SERVICE

Front Wheel Bearing (Cont'd)

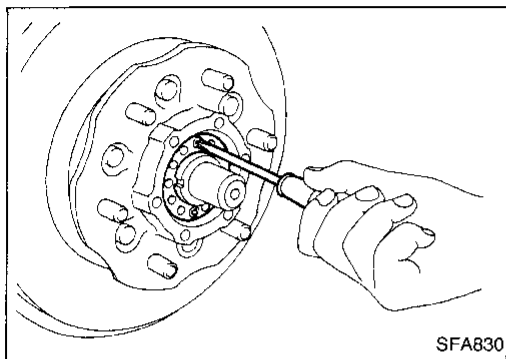

11. Install lock washer by tightening the lock nut within 15 to 30 degrees.
12. Turn wheel hub several times in both directions to seat wheel bearing correctly.
13. Measure starting force "B" at wheel hub bolt. Refer to step 10.
14. Wheel bearing preload "C" can be calculated as shown below.

$$C = B - A$$

Wheel bearing preload "C":

7.06 - 20.99 N (0.72 - 2.14 kg, 1.59 - 4.72 lb)

15. Repeat steps 3 through 14 until correct axial end play and wheel bearing preload are obtained.
16. Install free-running hub.

Front Wheel Alignment

Before checking front wheel alignment, make a preliminary inspection (Unladen*).

*: Fuel, radiator coolant and engine oil full. Spare tire, jack, hand tools and mats in designated positions.

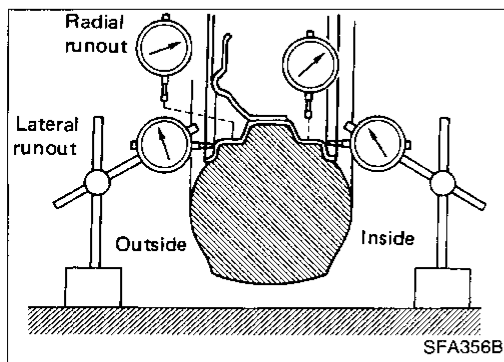

PRELIMINARY INSPECTION

1. Check tires for wear and proper inflation.
2. Check outside and inside wheel runout.

Wheel runout average

[(Outside runout value + Inside runout value) x 0.5]:

Refer to SDS, FA-48.

3. Check front wheel bearings for looseness.
4. Check front suspension for looseness.
5. Check steering linkage for looseness.
6. Check that front shock absorbers work properly by using the standard bounce test.

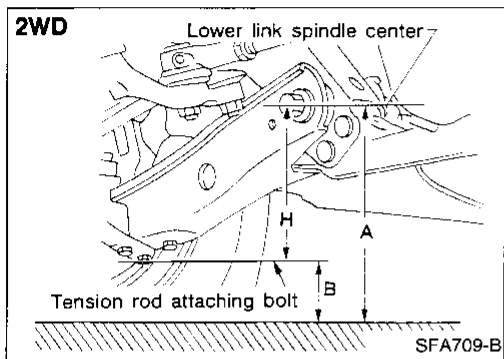

7. Measure vehicle height (Unladen): $H = A - B$ mm (in)

Refer to SDS, FA-46.

- a. Exercise the front suspension by bouncing the front of the vehicle 4 or 5 times to ensure that the vehicle is in a neutral height attitude.
- b. Measure wheel alignment.
Refer to ALLOWABLE LIMIT in SDS, FA-46.
- c. If wheel alignment is not as specified, adjust vehicle posture.
Refer to ADJUSTING RANGE in SDS, FA-46.
- d. Adjust wheel alignment.
Refer to ADJUSTING RANGE in SDS, FA-46.

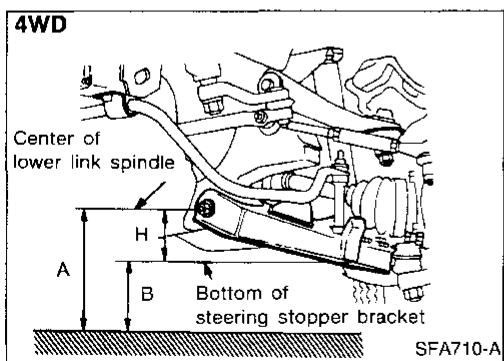

ON-VEHICLE SERVICE

Front Wheel Alignment (Cont'd)

CAMBER, CASTER AND KINGPIN INCLINATION

Before checking camber, caster or kingpin inclination, move vehicle up and down on turning radius gauge to minimize friction. Ensure that the vehicle is in correct posture.

- Measure camber, caster and kingpin inclination of both right and left wheels with a suitable alignment gauge and adjust in accordance with the following procedures.

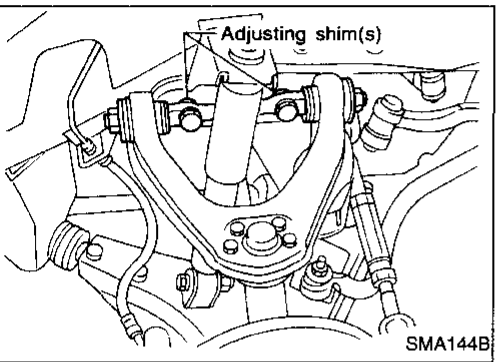
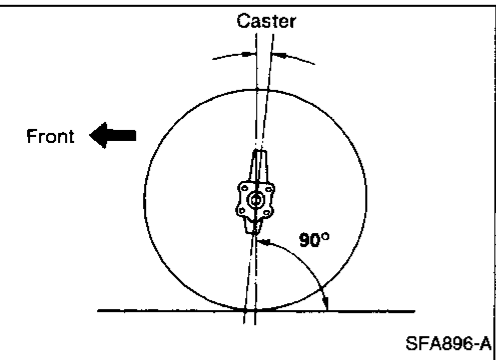
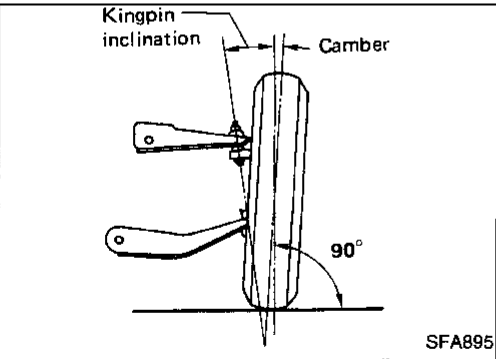
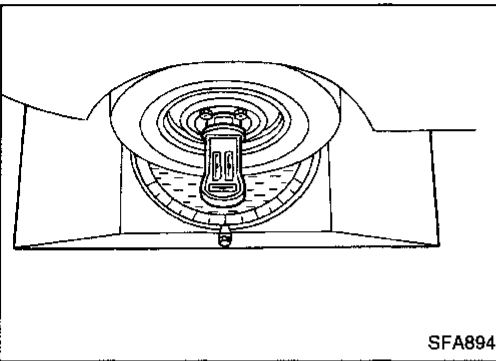

Camber (Unladen):

Refer to SDS, FA-46.

Kingpin inclination (Unladen):

Refer to SDS, FA-46.

Caster (Unladen):

Refer to SDS, FA-46.

ADJUSTMENT

Both camber and caster angles are adjusted by increasing or decreasing the number of adjusting shims inserted between upper link spindle and frame.

GI
MA
EM
LC
EC
FE
CL
MT
AT
TF
PD
FA
RA
BR
ST
RS
BT
HA
EL
IDX

ON-VEHICLE SERVICE

Front Wheel Alignment (Cont'd)

Before removing or installing adjusting shim(s), be sure to place a jack under lower link.

Adjusting shim standard thickness:

2WD

2.9 mm (0.114 in)

4WD

4.0 mm (0.157 in)

- Do not use four or more shims at one place.
- When installing shim B, always face the pawl towards spindle and insert it from bracket side. Use only one shim B in a place.
- Total thickness of shims must be within 8.0 mm (0.315 in).
- Difference of total thickness of the front and rear must be within 3.0 mm (0.118 in).
- Determine thickness and number of shims necessary for adjusting camber and caster, in accordance with the following graph.

[Example]

- When service data value minus measured value is equal to:
Caster angle: $-30'$
Camber angle: $+30'$
- Obtain the intersecting point of lines in accordance with the graph.
- Choose shims which are nearest to the intersecting point.
- For the above example:
2WD:
Add 2.0 mm (0.079 in) shim on front side.
Add 3.0 mm (0.118 in) shim on rear side.
4WD:
Add 1.0 mm (0.039 in) shim on front side.
Add 3.0 mm (0.118 in) shim on rear side.

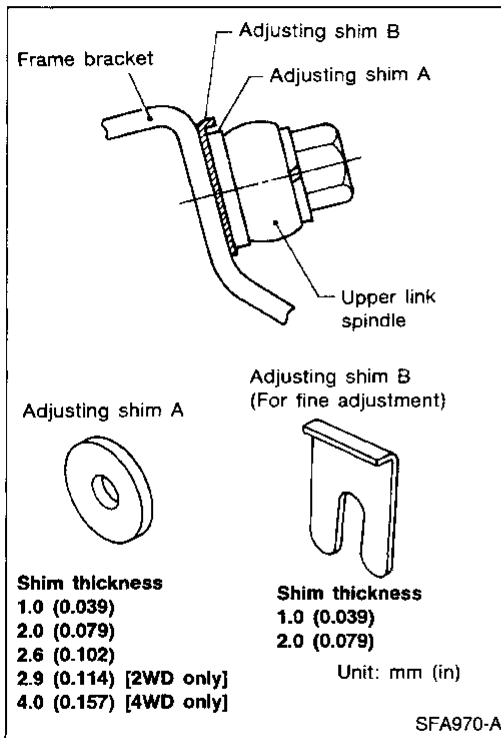

ON-VEHICLE SERVICE

Front Wheel Alignment (Cont'd)

2WD

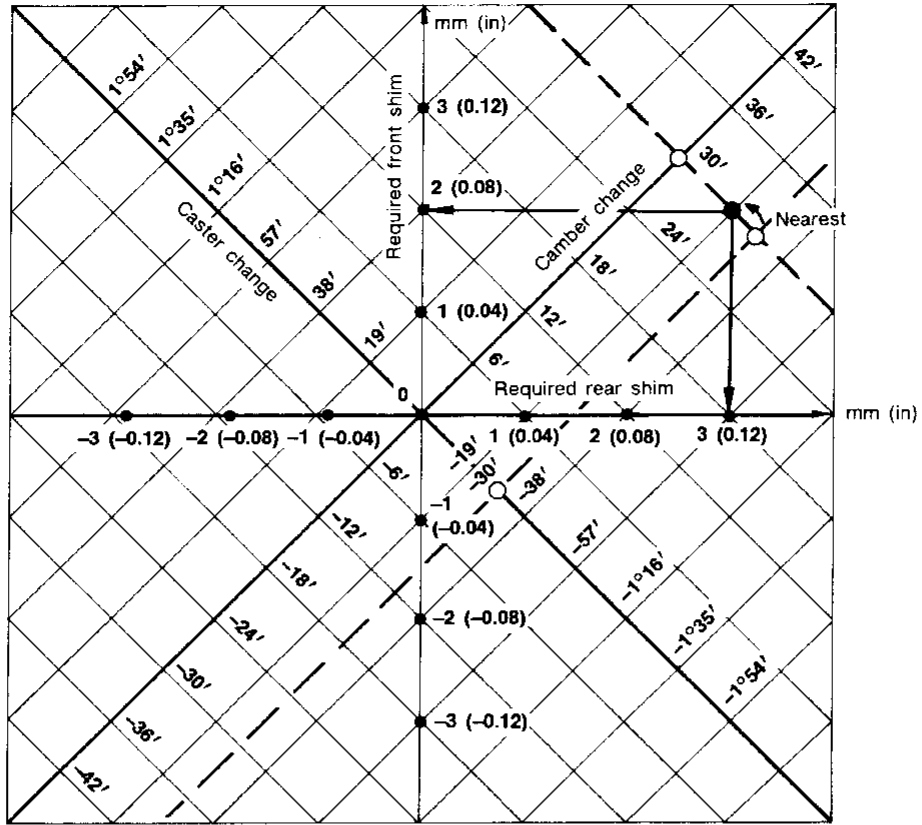

SFA477BA

4WD

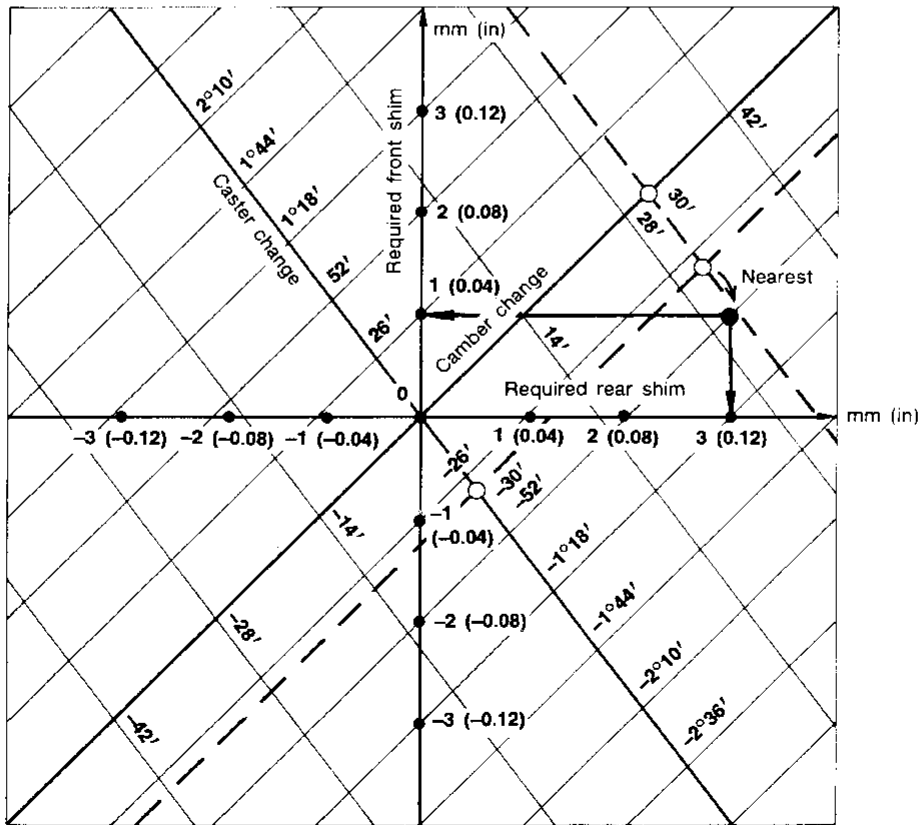

SFA478BA

- GI
- MA
- EM
- LC
- EC
- FE
- CL
- MT
- AT
- TF
- PD
- FA**
- RA
- BR
- ST
- RS
- BT
- HA
- EL
- IDX

ON-VEHICLE SERVICE

Front Wheel Alignment (Cont'd)

TOE-IN

Measure toe-in using the following procedure.

WARNING:

- Always perform the following procedure on a flat surface.
 - Make sure that no one is in front of the vehicle before pushing it.
1. Bounce front of vehicle up and down to stabilize the posture.
 2. Push the vehicle straight ahead about 5 m (16 ft).
 3. Put a mark on base line of the tread (rear side) of both tires at the same height of hub center. This mark is a measuring point.
 4. Measure distance "A" (rear side).
 5. Push the vehicle slowly ahead to rotate the wheels 180 degrees (1/2 turn).
 - If the wheels have rotated more than 180 degrees (1/2 turn), try the above procedure again from the beginning. Never push vehicle backward.
 6. Measure distance "B" (front side).

Total toe-in:

Refer to SDS, FA-46.

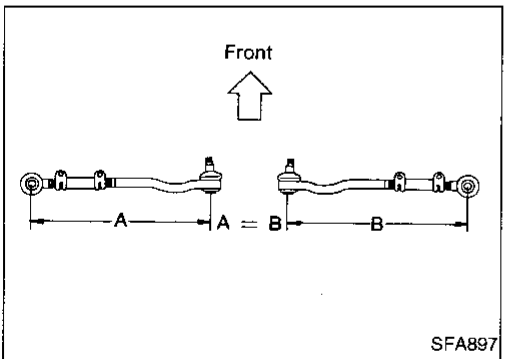
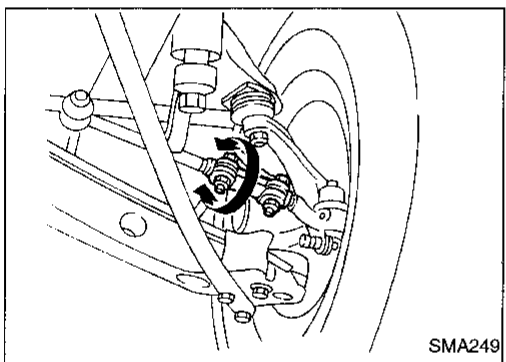
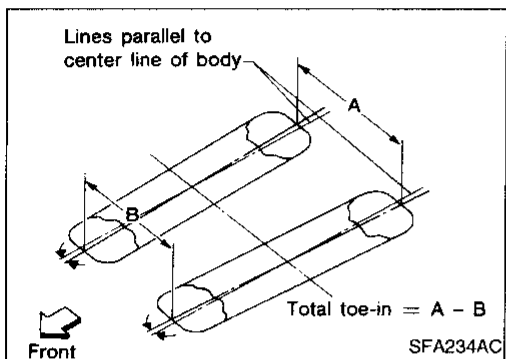
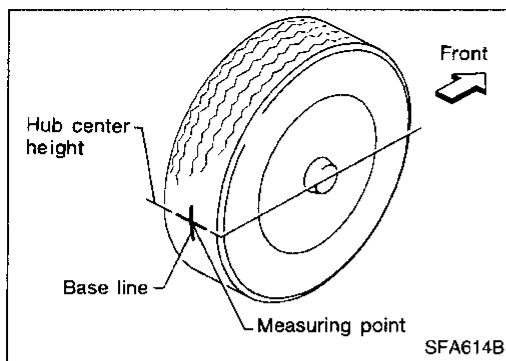

7. Adjust toe-in by varying the length of both steering tie-rods.
 - a. Loosen clamp bolts or lock nuts.
 - b. Adjust toe-in by turning both the left and right tie-rod tubes equal amounts.

Make sure that the tie-rod bars are screwed into the tie-rod tube more than 35 mm (1.38 in).

Make sure that the tie-rods are the same length.

Standard length (A = B):

2WD

344 mm (13.54 in)

4WD

281 mm (11.06 in)

- c. Tighten clamp bolts or lock nuts, then torque them.

ON-VEHICLE SERVICE

Front Wheel Alignment (Cont'd)

FRONT WHEEL TURNING ANGLE

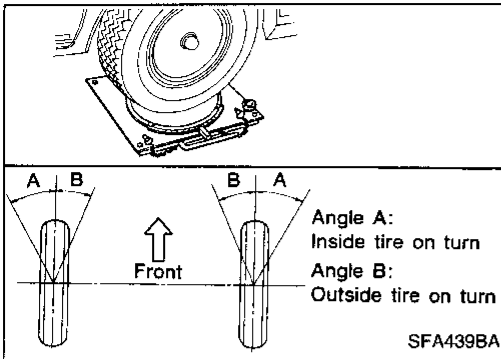

1. Set wheels in straight-ahead position. Then move vehicle forward until front wheels rest properly on turning radius gauge.
 2. Rotate steering wheel all the way right and left; measure turning angle.
- On power steering models, turn steering wheel to full lock and apply force (at circumference of steering wheel) of 98 to 147 N (10 to 15 kg, 22 to 33 lb) with engine at idle.
 - **Do not hold the steering wheel at full lock for more than 15 seconds.**

Wheel turning angle (Full turn):

Refer to SDS, FA-46.

3. Adjust stopper bolt if necessary.

[2WD]

Standard length "L₁": 20 mm (0.79 in)

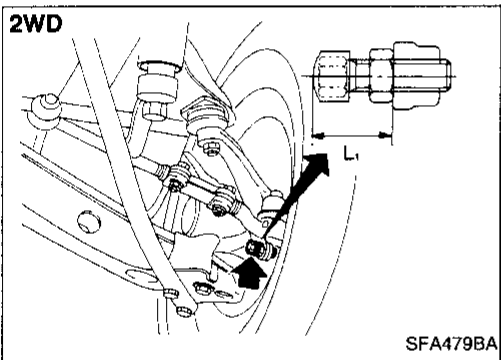

[4WD]

Standard length "L₂": 26.5 mm (1.043 in)

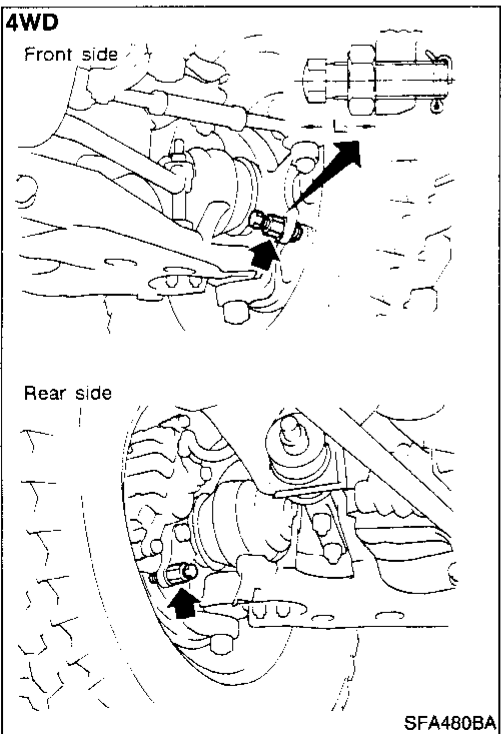

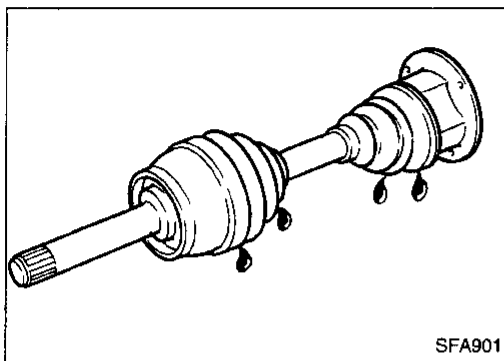

Drive Shaft

- Check for grease leakage and damage.

FRONT AXLE

2WD

SEC. 400

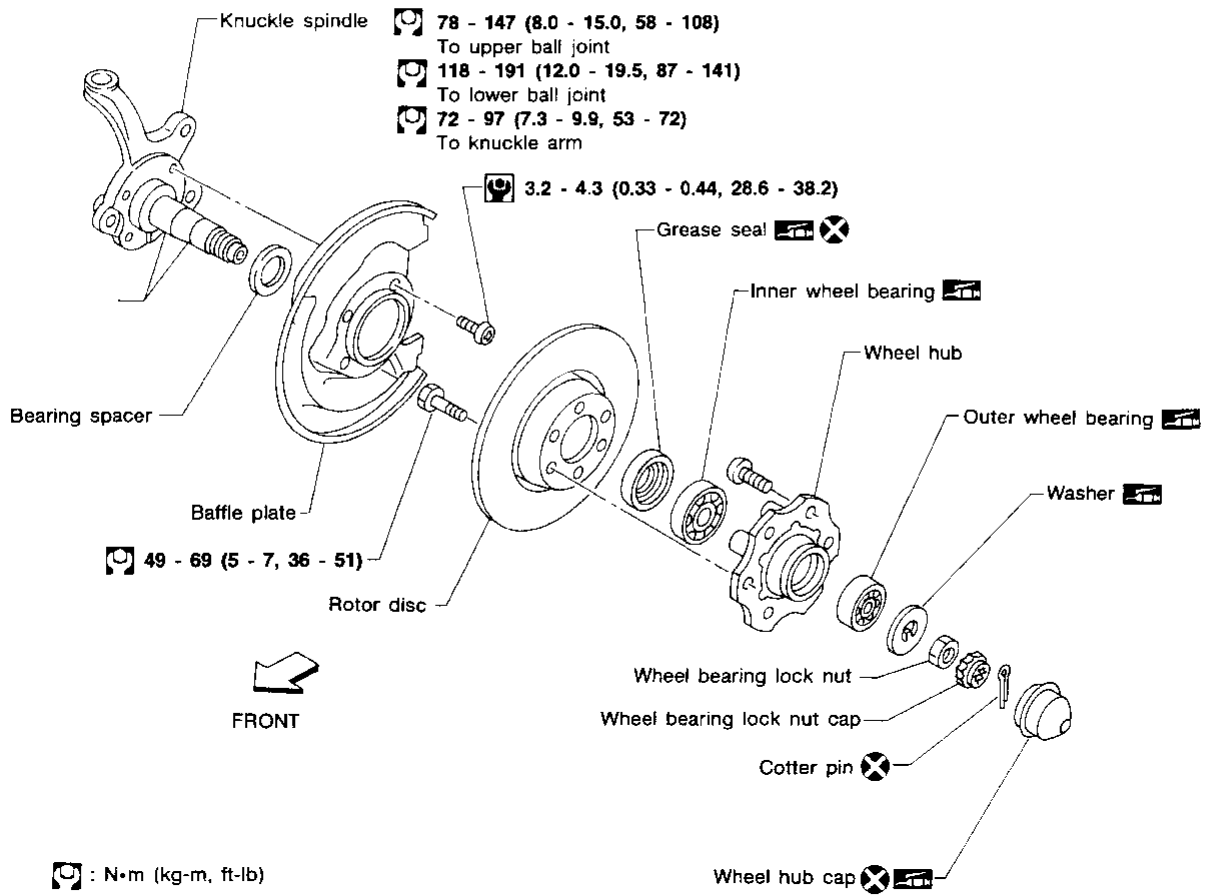

SFA559BA

GI
MA
EM
LC
EC
FE
CL
MT
AT
TF
PD
FA
RA
BR
ST
RS
BT
HA
EL
IDX

FRONT AXLE

4WD

SEC. 391-400

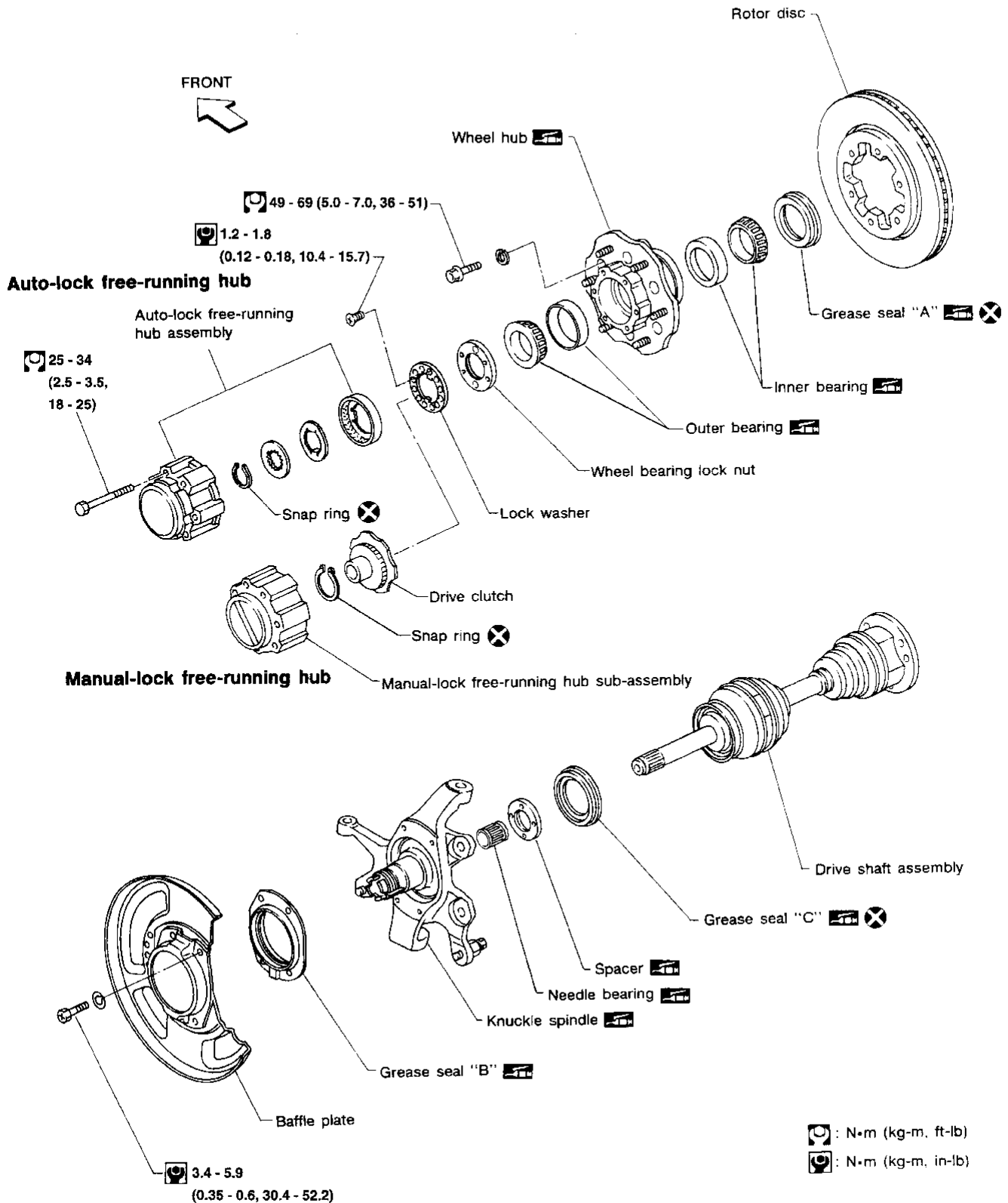

Manual-lock Free-running Hub

SEC. 400

*: Lubricating parts
When installing manual-lock free-running hub, use multi-purpose grease.

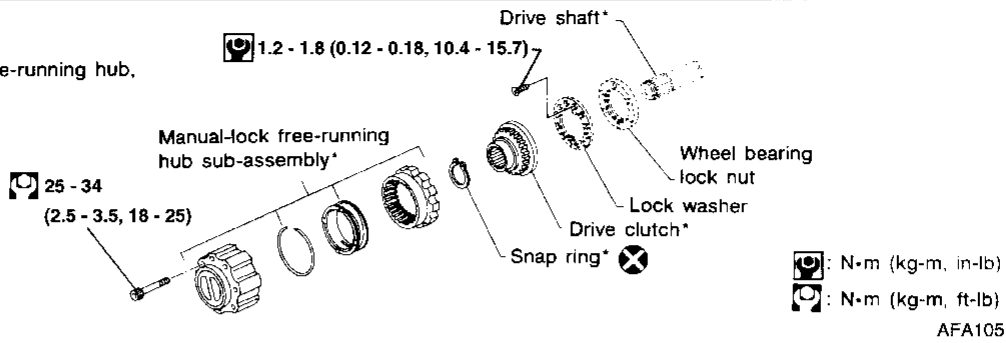

AFA105

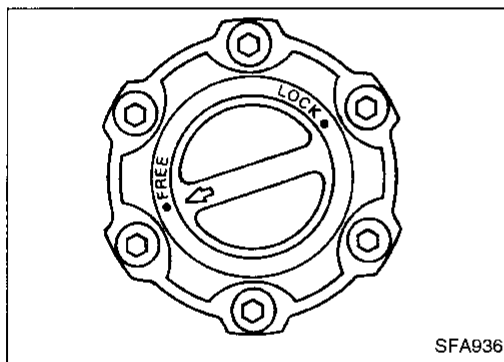

SFA936

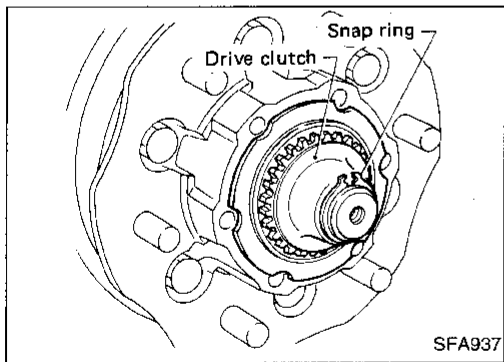

SFA937

REMOVAL AND INSTALLATION

- Set knob of manual-lock free-running hub in the FREE position.
- Remove manual-lock free-running hub with brake pedal depressed.
- Remove snap ring and then draw out drive clutch.

- When installing manual-lock free-running hub, make sure the hub is in the FREE position.

Apply multi-purpose grease to the parts shown in the above illustration.

- Check operation of manual-lock free-running hub after installation.

INSPECTION

- Check that the knob moves smoothly and freely.
- Check that the clutch moves smoothly in the body.

CI
MA
EM
LC
EC
FE
CL
MT
AT
TF
PD
FA
RA
BR
ST
RS
BT
HA
EL
IDX

Auto-lock Free-running Hub

SEC. 400

*: Lubricating parts
When installing auto-lock free-running hub, use NISSAN GENUINE GREASE (KRC19-00025) or equivalent grease.

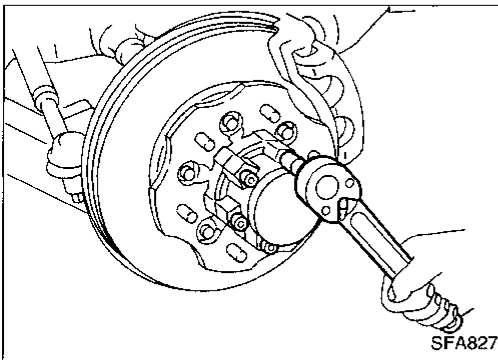
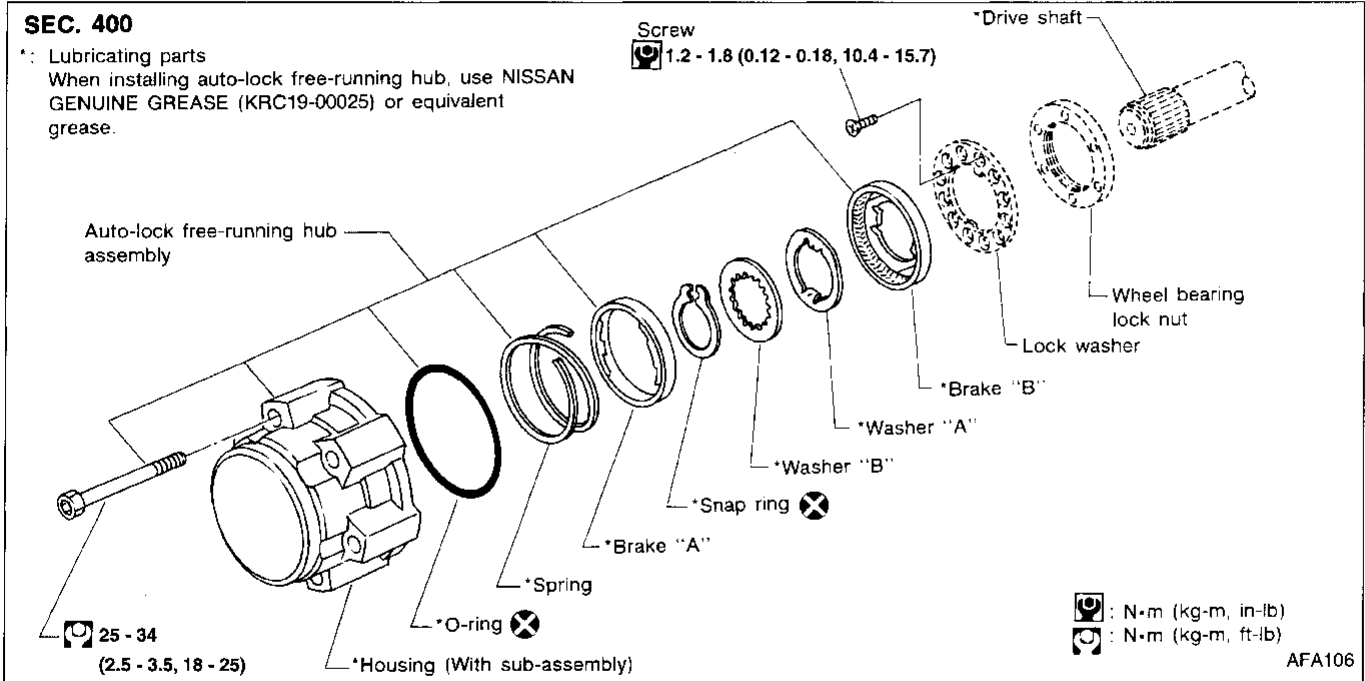

REMOVAL AND INSTALLATION

- Set auto-lock free-running hub in the FREE position.
- Remove auto-lock free-running hub with brake pedal depressed.

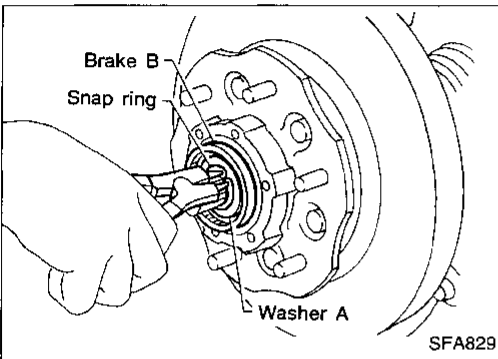

- Remove snap ring.
- Remove washer B, washer A and brake B.
- After installing auto-lock free-running hub, check operation.

When installing it, apply recommended grease to the parts shown in the above illustration.

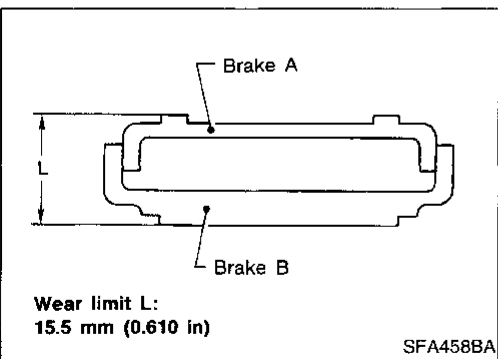

INSPECTION

Thoroughly clean parts with cleaning solvent and dry with compressed air.

Brake "A" and "B"

Measure the thickness "L" of brake "A" and "B". If thickness is less than the specified limit, replace brake "A" and "B" as a set.

FRONT AXLE (4WD)

Auto-lock Free-running Hub (Cont'd)

TROUBLE-SHOOTING

Noise occurring in the auto-lock free-running hub under any of the conditions described below is not indicative of a problem. Noise can be eliminated by properly operating the transfer lever.

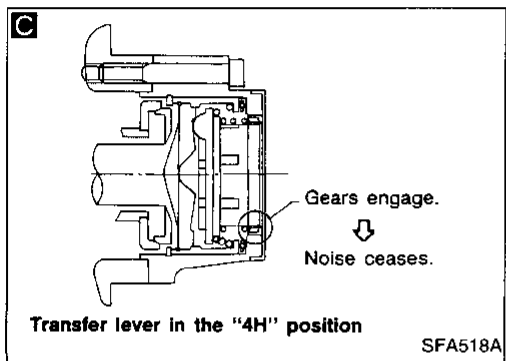
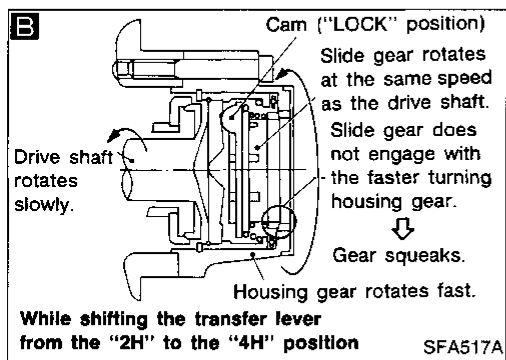
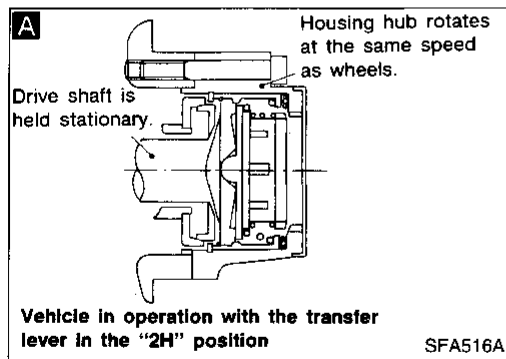

Noise

Was the transfer lever shifted from the "2H" to the "4H" position while the vehicle was operated at a speed greater than 40 km/h (25 MPH)?

Yes

Shifting the transfer lever from the "2H" to the "4H" position in high-speed operation (Fig. **A** → Fig. **B**), is sometimes difficult. At this point, a clattering occurs in the auto hub. If shifting is stopped halfway, the drive shaft no longer rotates and the cam is held in the "LOCK" position (Fig. **B**). In this case, the noise will continue until the vehicle is stopped. When this occurs, decrease vehicle speed to less than 40 km/h (25 MPH), return the transfer lever to the "2H" position once and then reshift to the "4H" position. Gears will then be engaged and the noise will cease (Fig. **C**).

No

A

(Go to next page.)

GI

MA

EM

LC

EC

FE

CL

MT

AT

TF

PD

FA

RA

BR

ST

RS

BT

HA

EL

IDX

FRONT AXLE (4WD)

Auto-lock Free-running Hub (Cont'd)

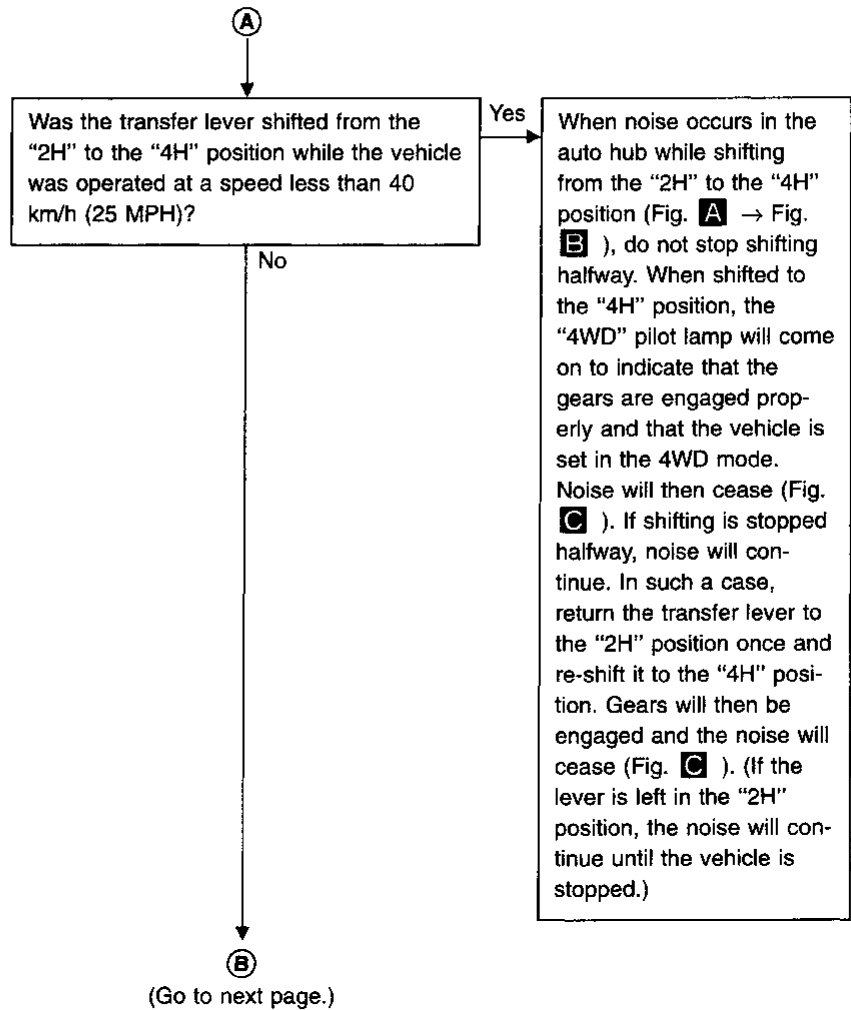

FRONT AXLE (4WD)

Auto-lock Free-running Hub (Cont'd)

GI
MA
EM
LC
EC
FE
CL
MT
AT
TF
PD
FA
RA
BR
ST
RS
BT
HA
EL
IDX

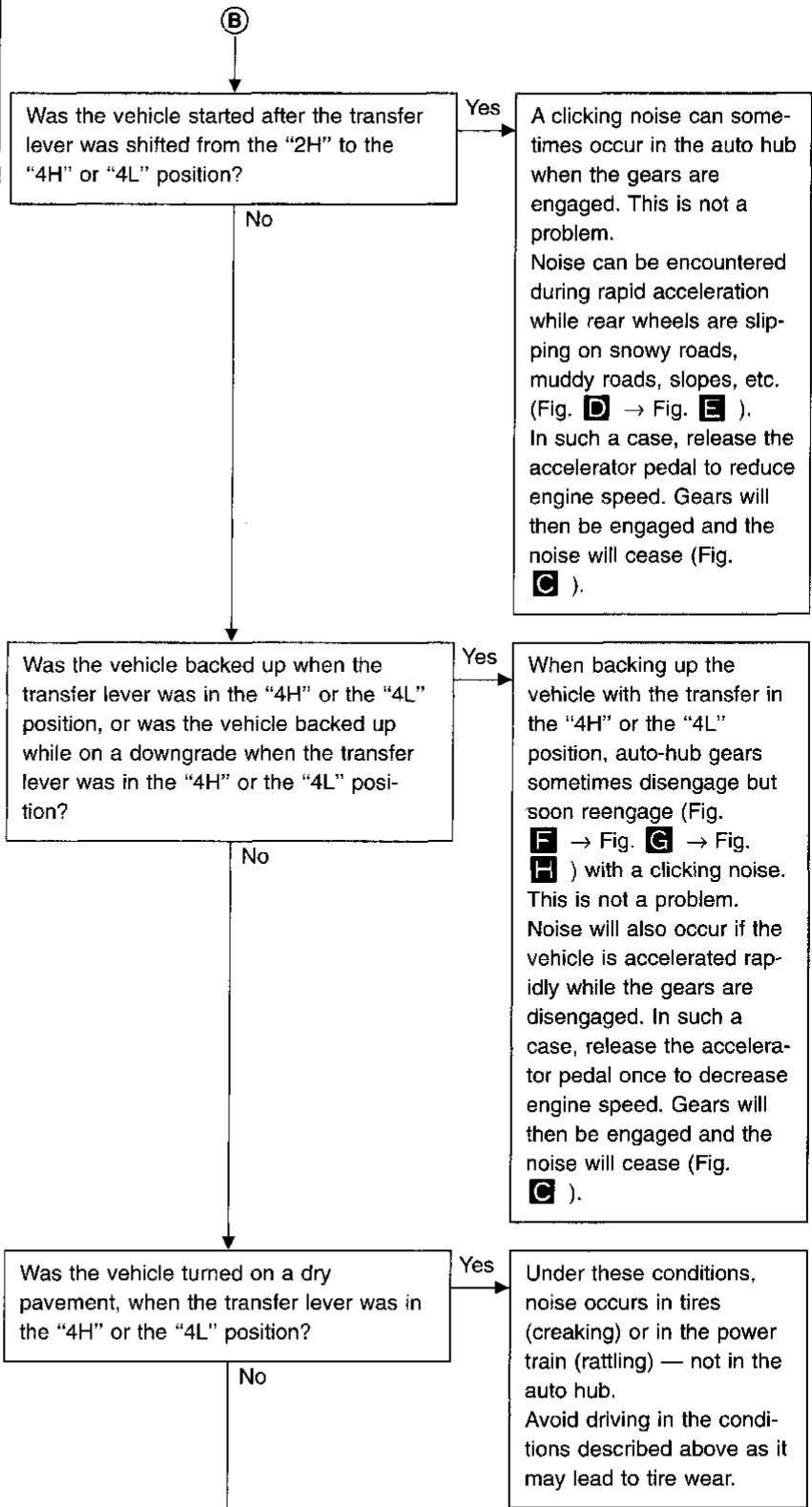
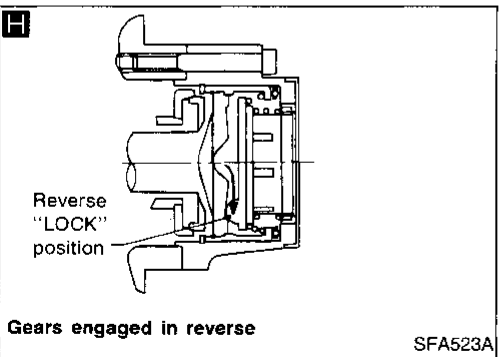
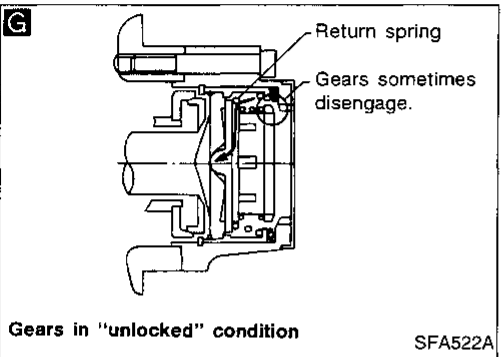
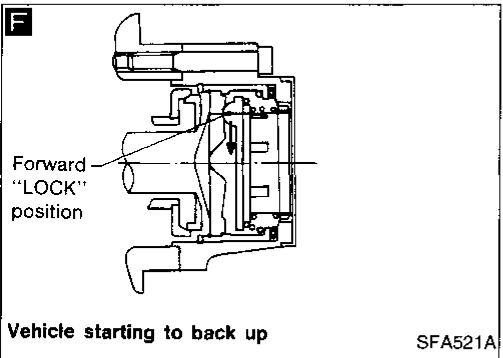
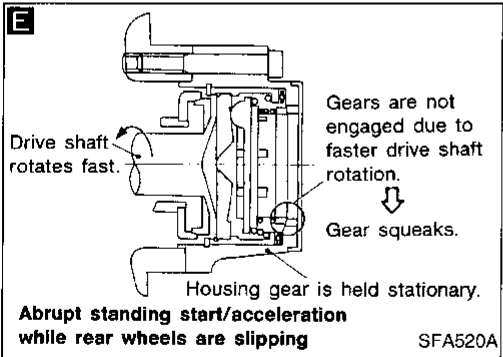
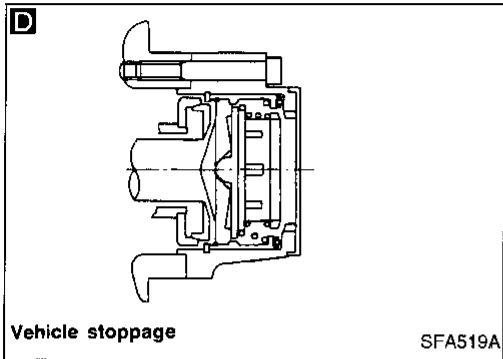

FRONT AXLE (4WD)

Auto-lock Free-running Hub (Cont'd)

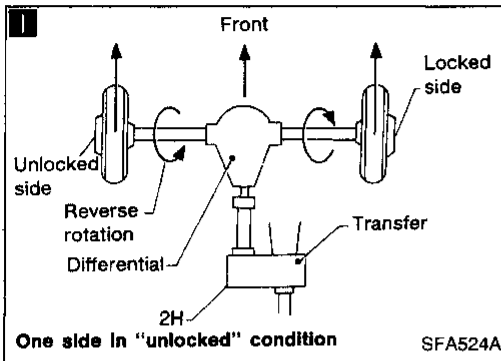

Was the vehicle moved in one direction after the vehicle was driven in another direction when the transfer lever was in the "4H" or the "4L" position and then returned to the "2H" position?

Yes

Auto-hub gears will disengage with a resultant noise (clicking). If the distance the vehicle is moved in the opposite direction is short [less than 1 m (3 ft)] or if the rotation angle of the left and right wheels is not the same (as in rounding a corner), gears on one side will disengage (Fig. 1). Under this condition, a noise (crushing, etc.) might occur while driving in the "2H" position. If only gears on one side are unlocked, the locked drive shaft rotates at the same speed as wheels; however, the unlocked drive shaft is made to rotate in the reverse direction by the differential. This forces the auto hub's slide gear to lock in the reverse direction. As a result, noise occurs.

If this happens, slowly move the vehicle straight back approximately 2 to 3 m (7 to 10 ft) with the transfer lever in the "2H" position to disengage the gears on the other side.

No

D

(Go to next page.)

FRONT AXLE (4WD)

Auto-lock Free-running Hub (Cont'd)

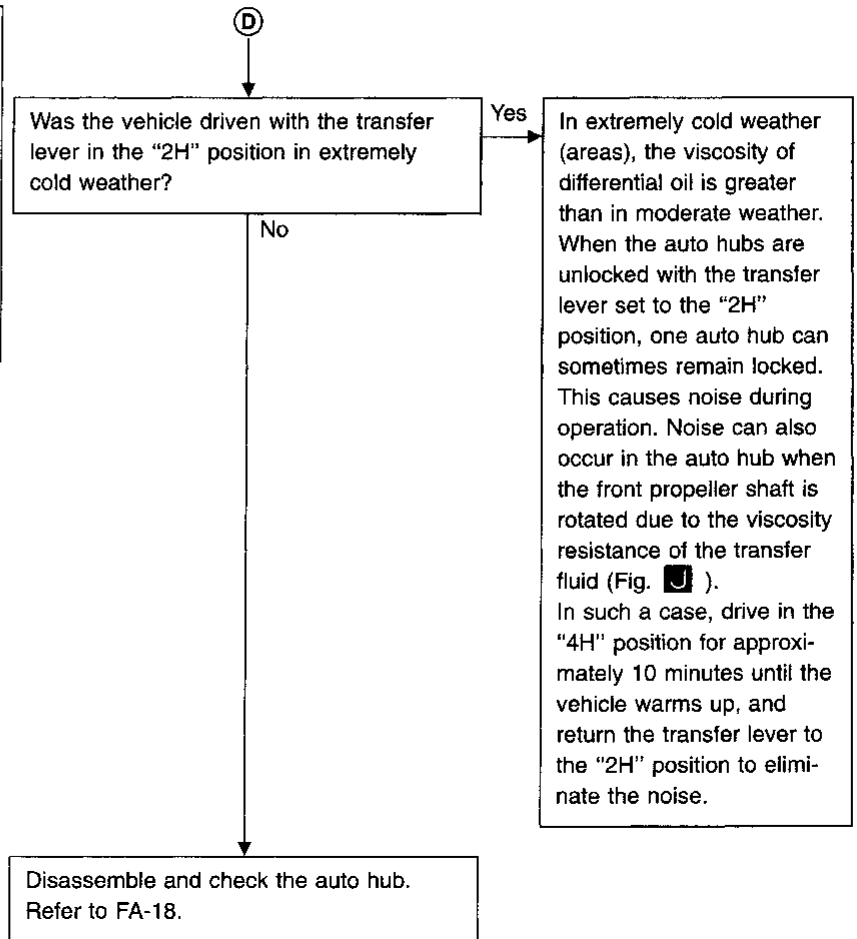
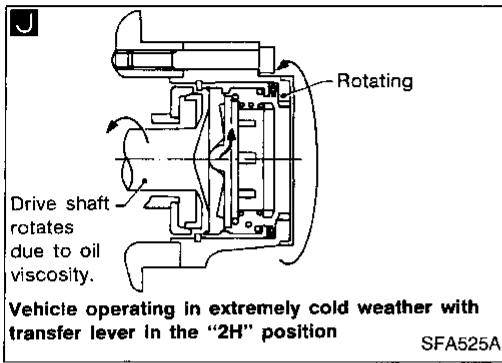

GI
MA
EM
LC
EC
FE
CL
MT
AT
TF
PD
FA
RA
BR
ST
RS
BT
HA
EL
IDX

FRONT AXLE

Wheel Hub and Rotor Disc

REMOVAL AND INSTALLATION

- Remove free-running hub assembly. — 4WD —
Refer to FRONT AXLE (4WD) — Auto-lock Free-running Hub or Manual-lock Free-running Hub, FA-17.
- Remove brake caliper assembly without disconnecting hydraulic line.

Be careful not to depress brake pedal, or piston will pop out. Make sure brake hose is not twisted.

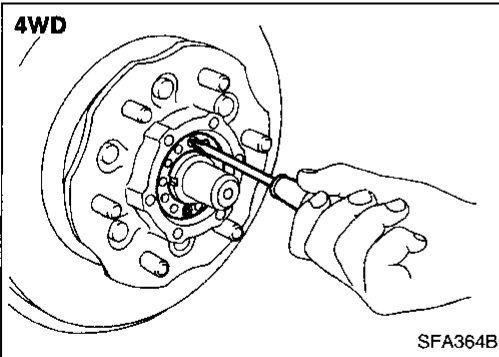
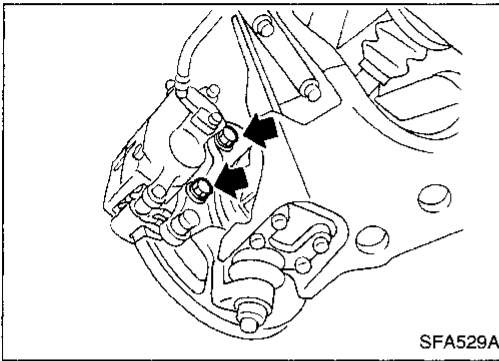

- Remove lock washer. — 4WD —

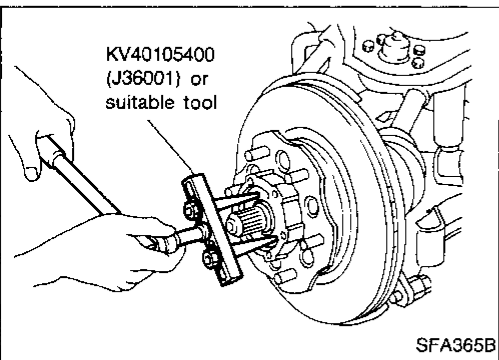

- Remove wheel bearing lock nut.
2WD: With suitable tool
4WD: With Tool

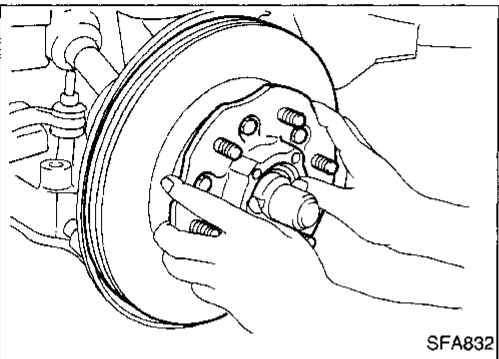

- Remove wheel hub and wheel bearing.

Be careful not to drop outer bearing.

- After installing wheel hub and wheel bearing, adjust wheel bearing preload.
Refer to PRELOAD ADJUSTMENT of Front Wheel Bearing in ON-VEHICLE SERVICE, FA-6.

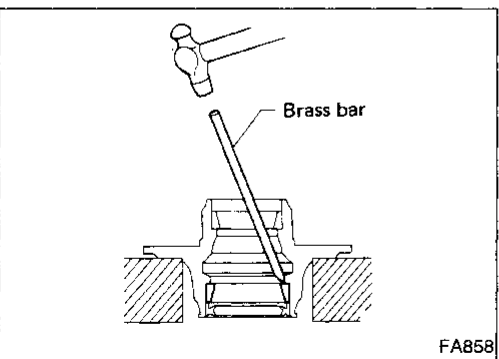

DISASSEMBLY

- Remove bearing outer races with suitable brass bar.

FRONT AXLE

Wheel Hub and Rotor Disc (Cont'd)

INSPECTION

Thoroughly clean wheel bearings and wheel hub.

Wheel bearings

- Make sure wheel bearings roll freely and are free from noise, cracks, pitting and wear.

Wheel hub

- Check wheel hub for cracks by using a magnetic exploration or dyeing test.

ASSEMBLY

- Install bearing outer race with Tool until it seats in hub.

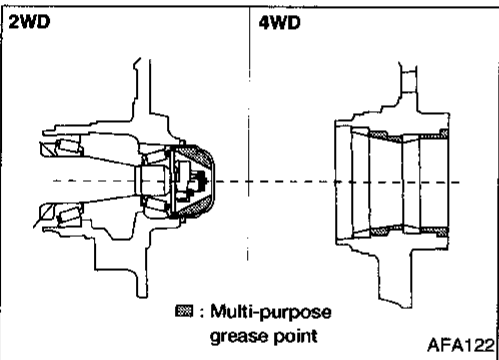
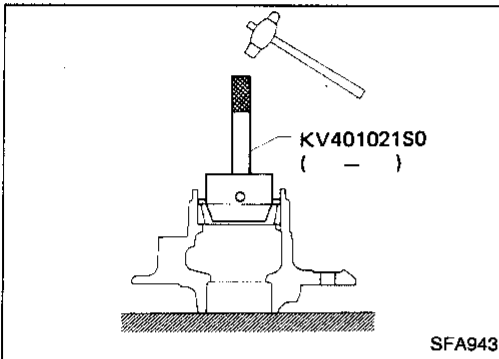

- Pack multi-purpose grease in wheel hub and hub cap.

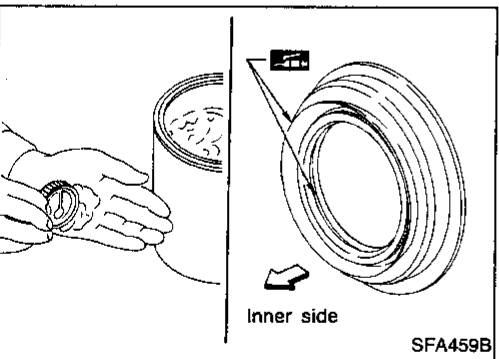

- Apply multi-purpose grease to each bearing cone.
- Pack grease seal lip with multi-purpose grease, then install it into wheel hub with suitable drift.

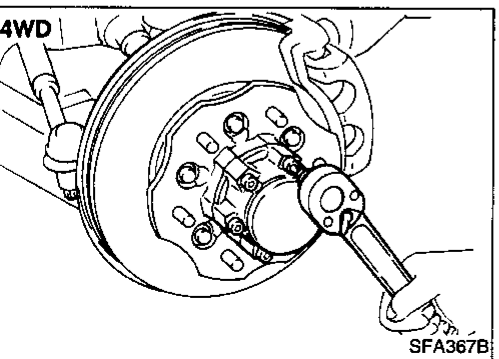

Knuckle Spindle

REMOVAL

- Remove free-running hub assembly. — 4WD —
Refer to FRONT AXLE (4WD) — Auto-lock Free-running Hub or Manual-lock Free-running Hub, FA-17.

FRONT AXLE

Knuckle Spindle (Cont'd)

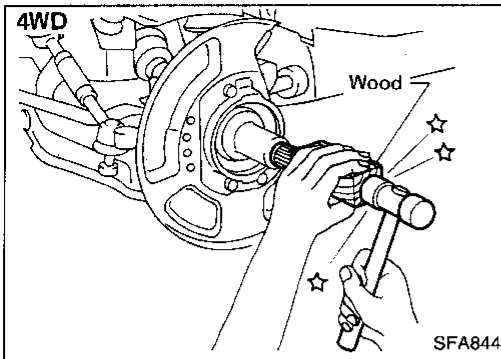

- Separate drive shaft from knuckle spindle by slightly tapping drive shaft end. — 4WD —

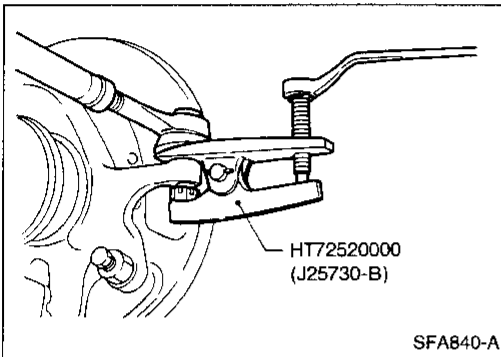

- Separate tie-rod from knuckle spindle with Tool.
Install stud nut conversely on stud bolt so as not to damage stud bolt.

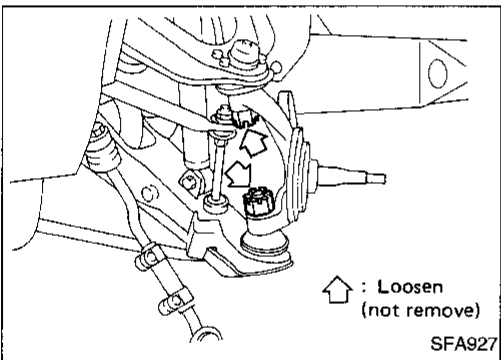

- Separate knuckle spindle from ball joints.
(1) Loosen (do not remove) upper and lower ball joint tightening nuts.

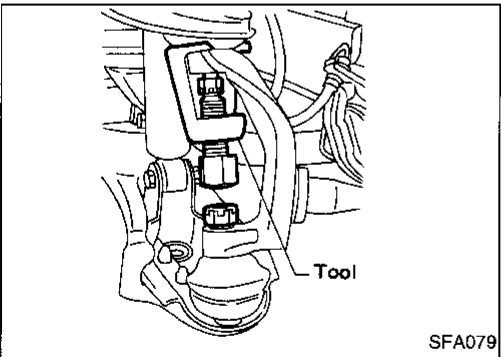

- (2) Separate knuckle spindle from upper and lower ball joint studs with Tool.

During above operation, never remove ball joint nuts which are loosened in step (1) above.

Tool:

- 2WD
ST29020001 (J24319-01)
- 4WD
HT72520000 (J25730-B)

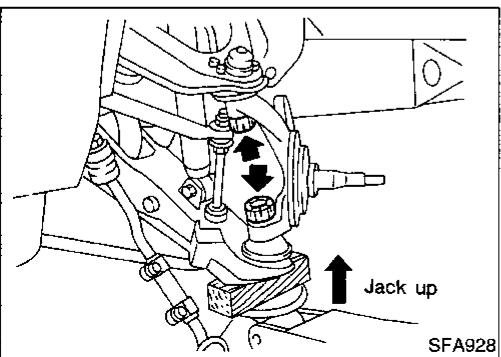

- (3) Remove ball joint tightening nuts.

Support lower link with jack.

- (4) Remove knuckle spindle from upper and lower links.

INSPECTION

Knuckle spindle

- Check knuckle spindle for deformation, cracks and other damage by using a magnetic exploration or dyeing test.

FRONT AXLE

Knuckle Spindle (Cont'd)

Bearing spacer — 2WD —

- Check bearing spacer for damage.

Needle bearing — 4WD —

- Check needle bearing for wear, scratches, pitting, flaking and burn marks.

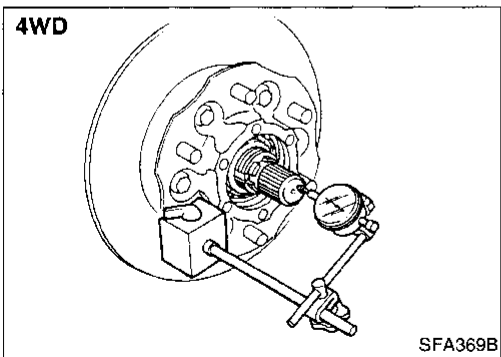
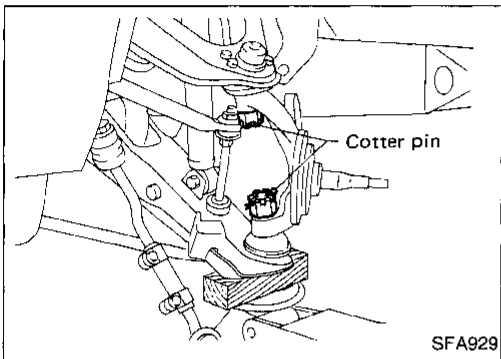
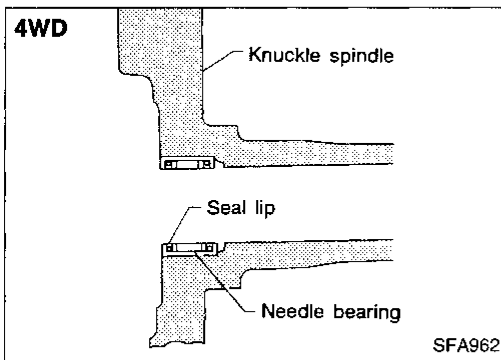
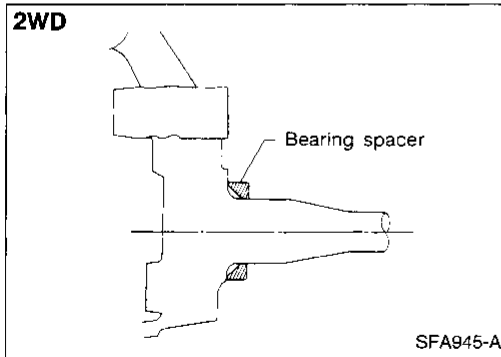

INSTALLATION

- Install bearing spacer onto knuckle spindle. — 2WD —

Make sure that bearing spacer is facing in proper direction. Apply multi-purpose grease.

- Install needle bearing into knuckle spindle. — 4WD —

Make sure that needle bearing is facing in the proper direction. Apply multi-purpose grease.

- Install knuckle spindle to upper and lower ball joints with lower link jacked up.

CAUTION:

Make sure that oil and grease do not come into contact with tapered areas of ball joint, knuckle spindle and threads of ball joint.

- Connect tie-rod to knuckle spindle.

- After installing knuckle spindle, adjust wheel bearing preload. Refer to PRELOAD ADJUSTMENT of Front Wheel Bearing in ON-VEHICLE SERVICE, FA-6.

- After installing drive shaft, check drive shaft axial end play.

Do not reuse snap ring once it has been removed.

Refer to FRONT AXLE (4WD) — Drive shaft, FA-28.

FRONT AXLE (4WD)

Drive Shaft

SEC. 391
KA24E

Wheel side (ZF100)

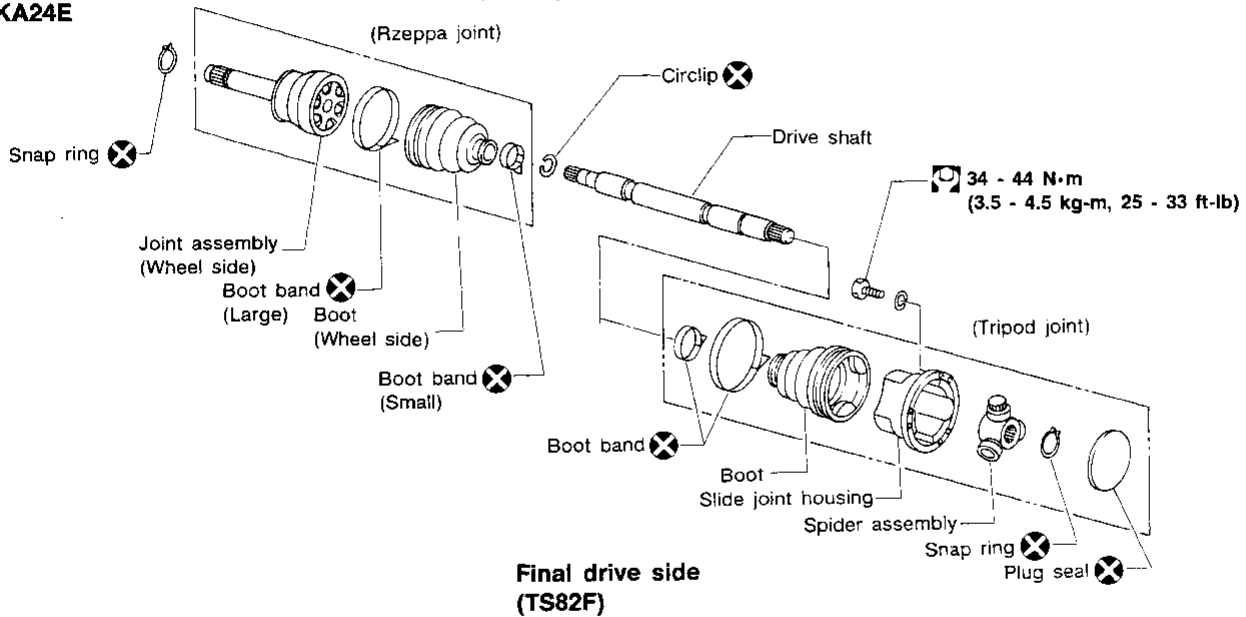

SFA874-A

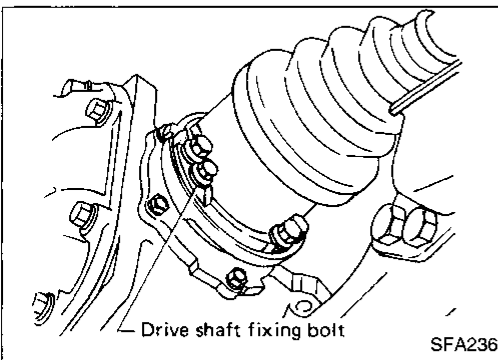

REMOVAL

1. Remove bolts fixing drive shaft to final drive.
2. Remove free-running hub assembly with brake pedal depressed. Refer to FRONT AXLE (4WD) — Auto-lock Free-running Hub or Manual-lock Free-running Hub, FA-17.
3. Remove brake caliper assembly without disconnecting brake hydraulic line.

Be careful not to depress brake pedal, or piston will pop out. Make sure that the brake hose is not twisted.

4. Remove tie-rod ball joint. Refer to FRONT AXLE — Knuckle Spindle, FA-25.
5. Remove nuts fixing lower ball joint on lower link.
Support lower link with jack.
6. Remove upper ball joint fixing bolt.
7. Remove shock absorber lower bolt.

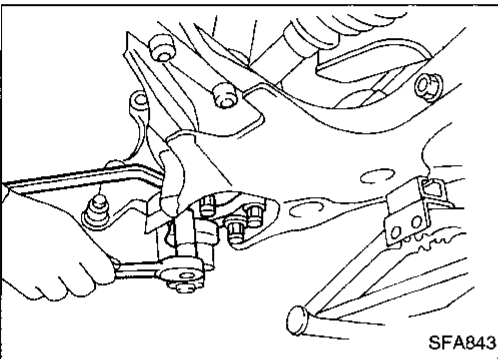

8. Remove drive shaft with knuckle.
Cover drive shaft boot with a suitable protector.

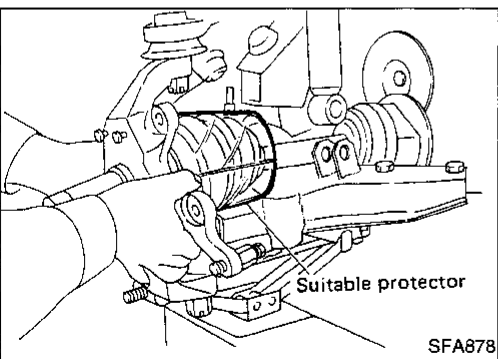

FRONT AXLE (4WD)

Drive Shaft (Cont'd)

9. Separate drive shaft from knuckle by slightly tapping it.

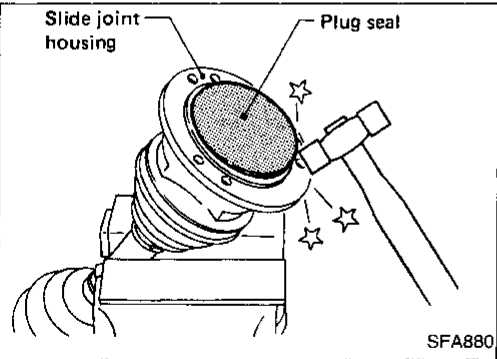
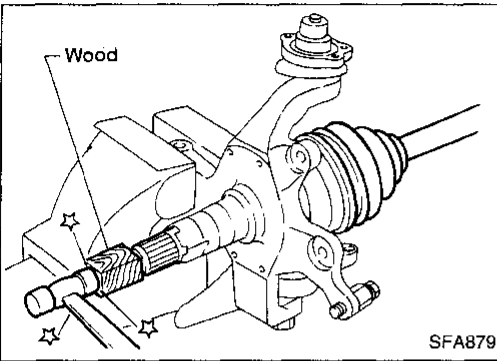

DISASSEMBLY

Final drive side (TS82F)

1. Remove plug seal from slide joint housing by lightly tapping around slide joint housing.
2. Remove boot bands.

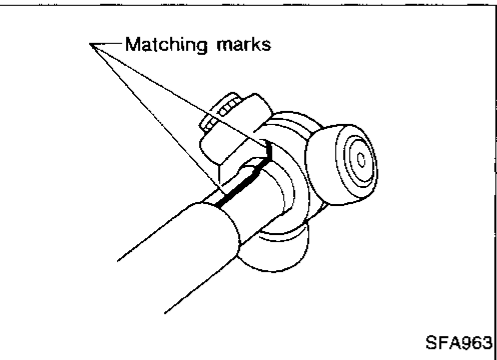

3. Move boot and slide joint housing toward wheel side, and put matching marks.

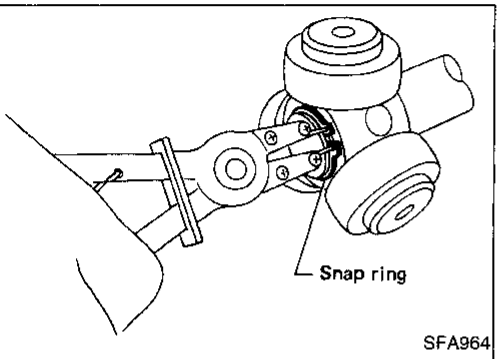

4. Remove snap ring.

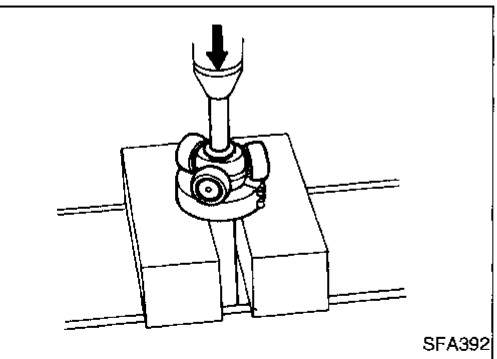

5. Detach spider assembly with press.

GI

MA

EM

LC

EC

FE

CL

MT

AT

TF

PD

FA

RA

BR

ST

RS

BT

HA

EL

IDX

FRONT AXLE (4WD)

Drive Shaft (Cont'd)

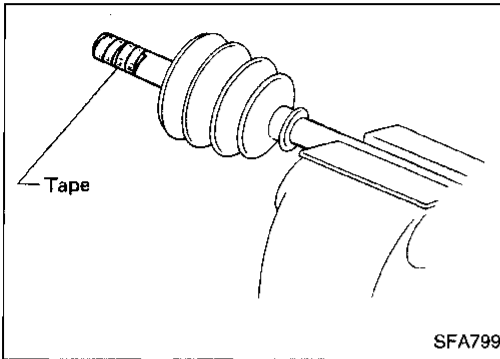

6. Draw out boot.

Cover drive shaft serration with tape to prevent damaging the boot.

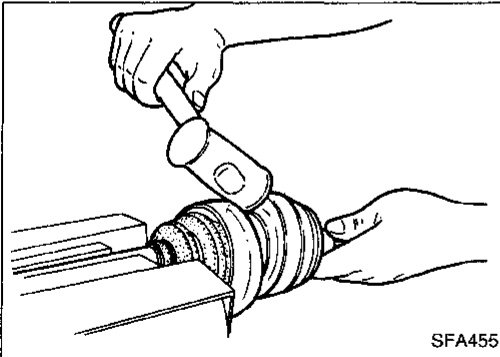

Wheel side (ZF100)

CAUTION:

The joint on the wheel side cannot be disassembled.

- Before separating joint assembly, put matching marks on drive shaft and joint assembly.
- Separate joint assembly with suitable tool.

Be careful not to damage threads on drive shaft.

- Remove boot bands.

INSPECTION

Thoroughly clean all parts in cleaning solvent, and dry with compressed air. Check parts for evidence of deformation or other damage.

Drive shaft

Replace drive shaft if it is twisted or cracked.

Boot

Check boot for fatigue, cracks and wear. Replace boot with new boot bands.

Joint assembly (Final drive side)

- Replace any parts of double offset joint which show signs of scorching, rust, wear or excessive play.
- Check serration for deformation. Replace if necessary.
- Check slide joint housing for any damage. Replace if necessary.

Joint assembly (Wheel side)

Replace joint assembly if it is deformed or damaged.

ASSEMBLY

- **After drive shaft has been assembled, ensure that it moves smoothly over its entire range without binding.**
- **Use NISSAN GENUINE GREASE or equivalent after every overhaul.**

FRONT AXLE (4WD)

Drive Shaft (Cont'd)

Final drive side (TS82F)

1. Install new small boot band, boot and side joint housing to drive shaft.

Cover drive shaft serration with tape to prevent damaging boot during installation.

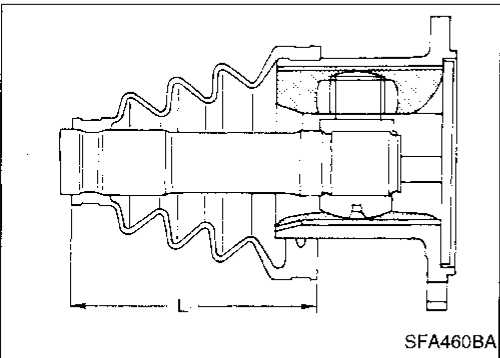
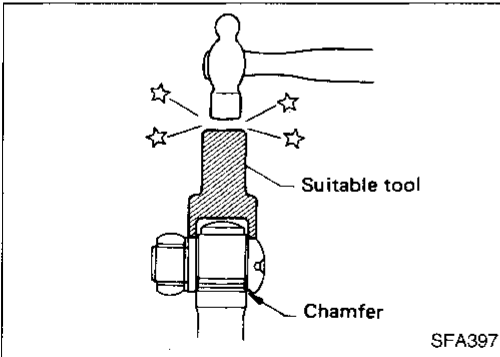
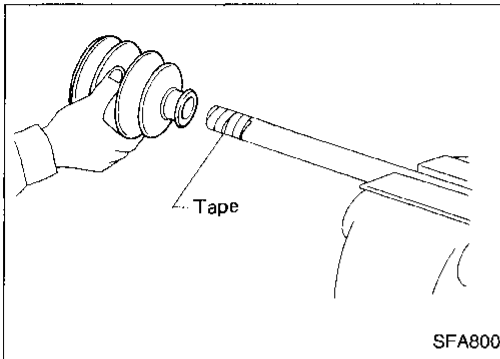

4. Pack with grease.

Specified amount of grease:

95 - 105 g (3.35 - 3.70 oz)

5. Make sure that the boot is properly installed on the drive shaft groove. Set the boot so that it does not swell or deform when its length is "L₁".

Length "L₁": 95 - 97 mm (3.74 - 3.82 in)

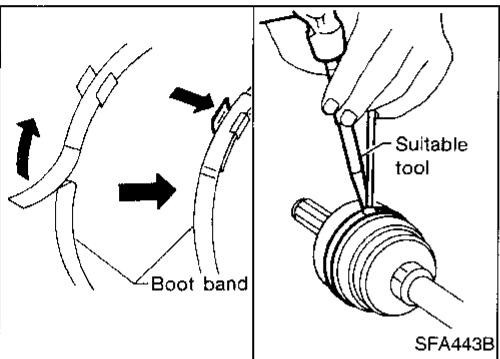

6. Lock new large boot band securely with a suitable tool, then lock new small boot band.

7. Install new plug seal to slide joint housing by lightly tapping it. **Apply sealant to mating surface of plug seal.**

Wheel side (ZF100)

1. Install new small boot band and boot on drive shaft.

Cover drive shaft serration with tape to prevent damaging boot during installation.

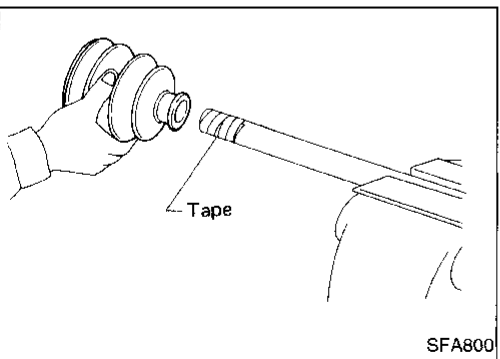

GI

MA

EM

LC

EC

FE

CL

MT

AT

TF

PD

FA

RA

BR

ST

RS

BT

HA

EL

IDX

FRONT AXLE (4WD)

Drive Shaft (Cont'd)

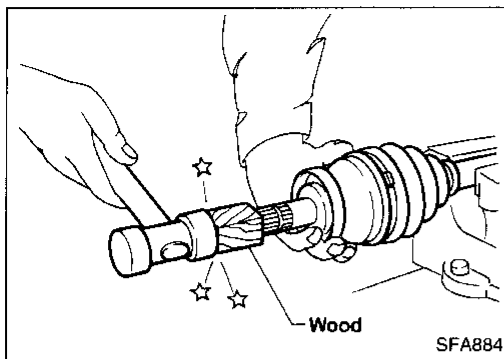

2. Set joint assembly onto drive shaft by lightly tapping it. Install joint assembly securely, ensuring that marks which were made during disassembly are properly aligned.

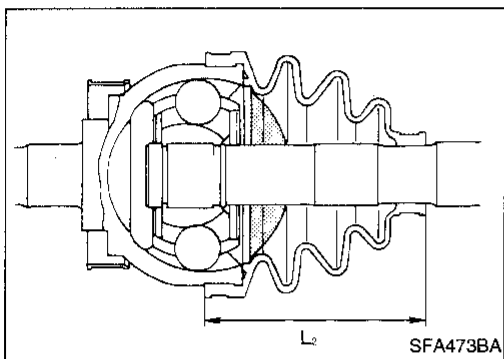

3. Pack drive shaft with specified amount of grease.
Specified amount of grease:
135 - 145 g (4.76 - 5.11 oz)
4. Make sure that the boot is properly installed on the drive shaft groove. Set the boot so that it does not swell or deform when its length is "L₂".
Length "L₂": 96 - 98 mm (3.78 - 3.86 in)
5. Lock new large boot band securely with a suitable tool.
6. Lock new small boot band.

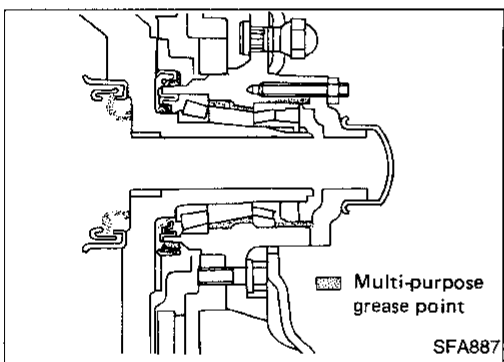

INSTALLATION

- Apply multi-purpose grease.

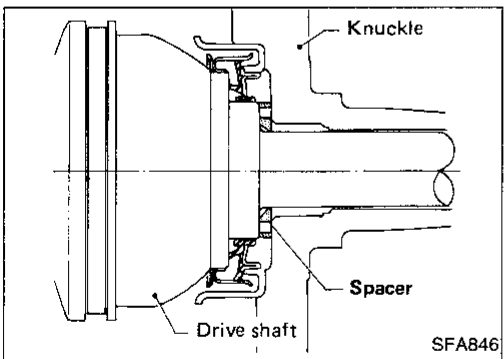

- Install bearing spacer onto drive shaft.
Make sure that the bearing spacer is facing in the proper direction.
- After installing wheel hub and wheel bearing, adjust wheel bearing preload. Refer to PRELOAD ADJUSTMENT of Front Wheel Bearing in ON-VEHICLE SERVICE, FA-6.

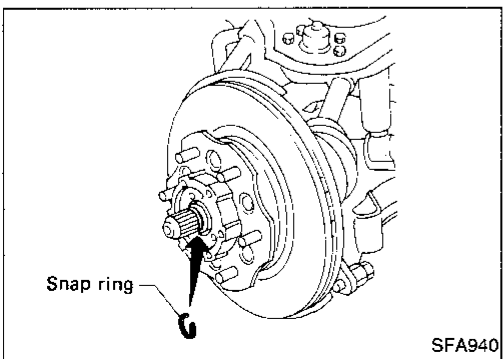

- When installing drive shaft, adjust drive shaft axial end play by selecting a suitable snap ring.
(1) Temporarily install new snap ring on drive shaft in the same thickness as it was installed before removal.

FRONT AXLE (4WD)

Drive Shaft (Cont'd)

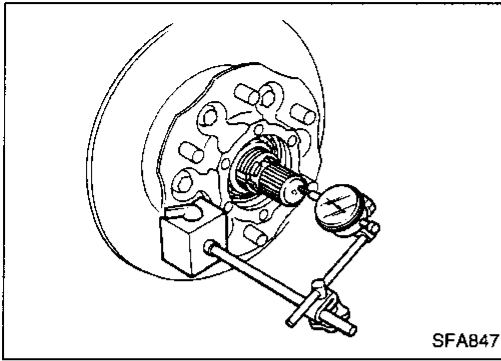

- (2) Set dial gauge on drive shaft end.
- (3) Measure axial end play of drive shaft.

Axial end play:

0.45 mm (0.0177 in) or less

- (4) If axial end play is not within the specified limit, select another snap ring.

1.1 mm (0.043 in)

1.3 mm (0.051 in)

1.5 mm (0.059 in)

1.7 mm (0.067 in)

1.9 mm (0.075 in)

2.1 mm (0.083 in)

2.3 mm (0.091 in)

GI

MA

EM

LC

EC

FE

CL

MT

AT

TF

PD

FA

RA

BR

ST

RS

BT

HA

EL

IDX

FRONT SUSPENSION

4WD

SEC. 401-406

Adjusting shims
When adjusting wheel alignment,
select them.

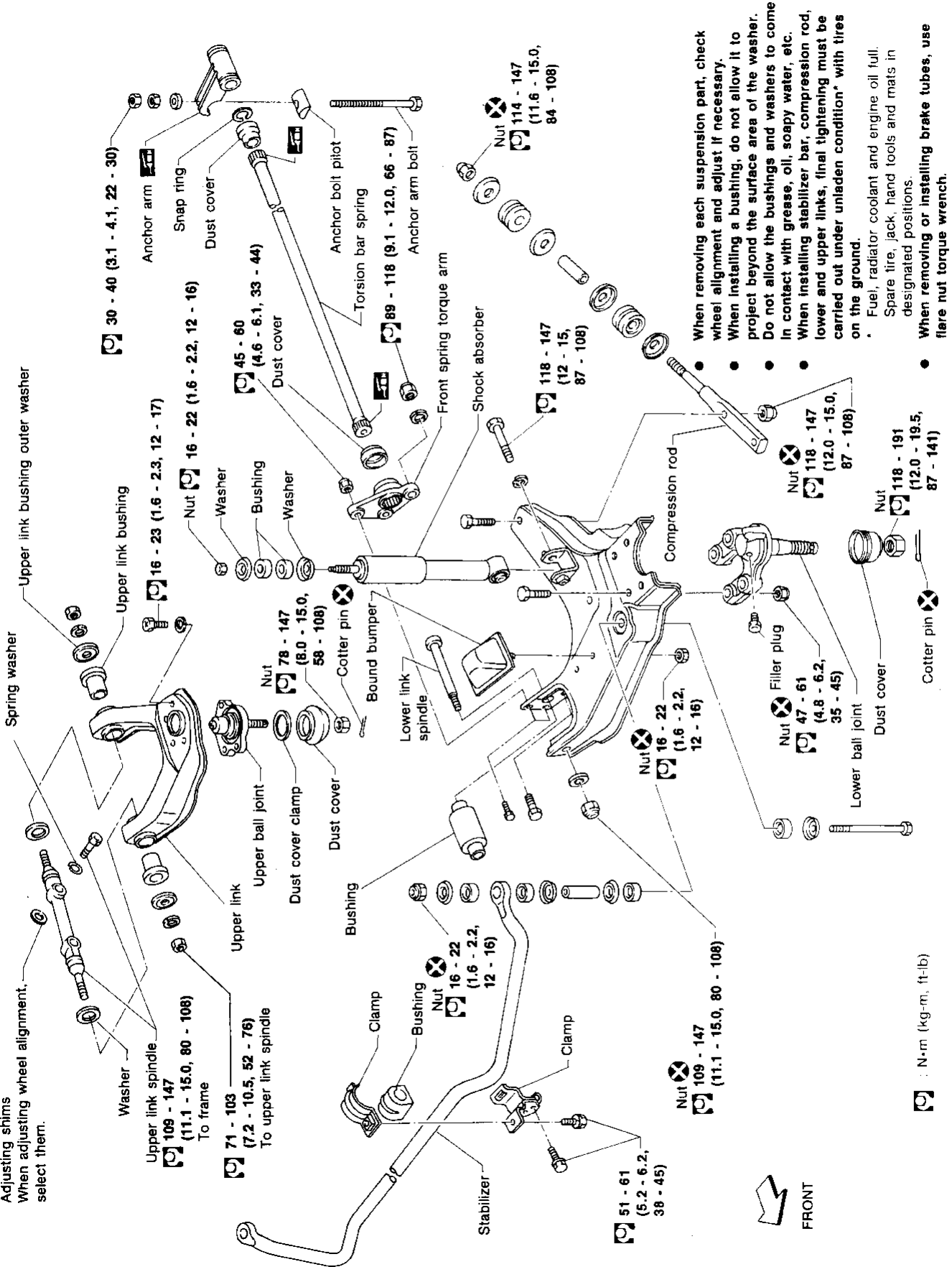

- GI
- MA
- EM
- LC
- EC
- FE
- CL
- MT
- AT
- TF
- PD
- FA
- RA
- BR
- ST
- RS
- BT
- HA
- EL
- IDX

AFA098

FRONT SUSPENSION

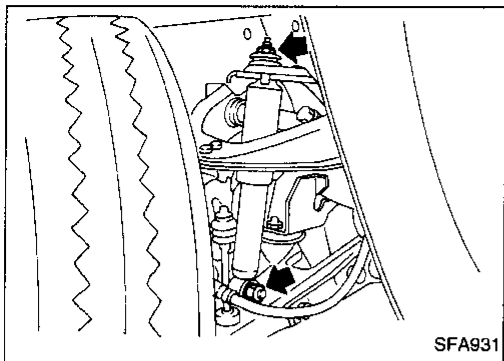

Shock Absorber

REMOVAL AND INSTALLATION

When removing and installing shock absorber, do not allow oil or grease to contact rubber parts.

INSPECTION

Except for nonmetallic parts, clean all parts with suitable solvent and dry with compressed air.

Use compressed air to blow dirt and dust off of nonmetallic parts.

- Check for oil leakage and cracks. Replace if necessary.
- Check piston rod for cracks, deformation and other damage. Replace if necessary.
- Check rubber parts for wear, cracks, damage and deformation. Replace if necessary.

Torsion Bar Spring

REMOVAL

- Remove adjusting nut.

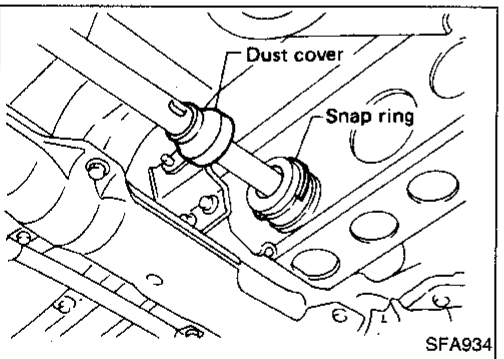
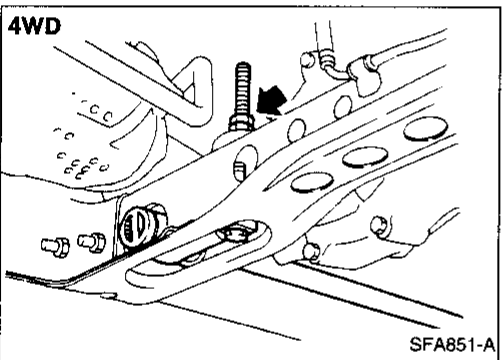
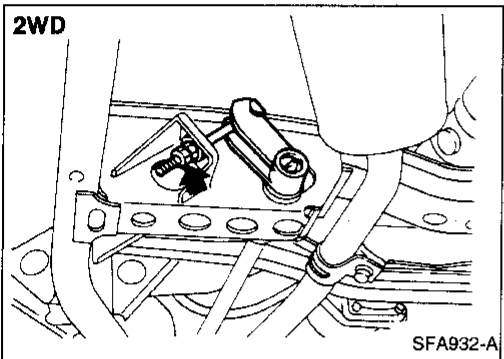

- Move dust cover, then detach snap ring from anchor arm.
- Pull out anchor arm rearward, then withdraw torsion bar spring rearward. — 2WD —
- Remove torque arm. — 2WD —

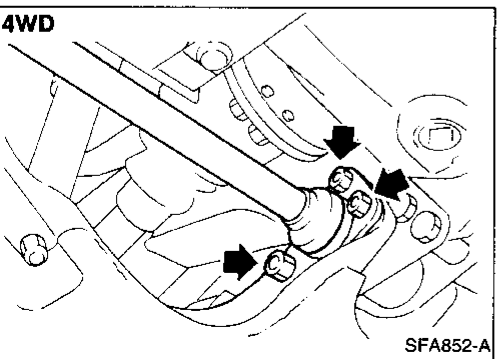

- Remove torque arm fixing nuts, then withdraw torsion bar spring forward with torque arm. — 4WD —

INSPECTION

- Check torsion bar spring for wear, twist, bend and other damage.
- Check serrations of each part for cracks, wear, twist and other damage.
- Check dust cover for cracks.

FRONT SUSPENSION

Torsion Bar Spring (Cont'd)

INSTALLATION AND ADJUSTMENT

Adjustment of anchor arm adjusting nut is in tightening direction only.

Do not adjust by loosening anchor arm adjusting nut.

1. Install torque arm to lower link. — 2WD —
2. Coat multi-purpose grease on the serration of torsion bar spring.

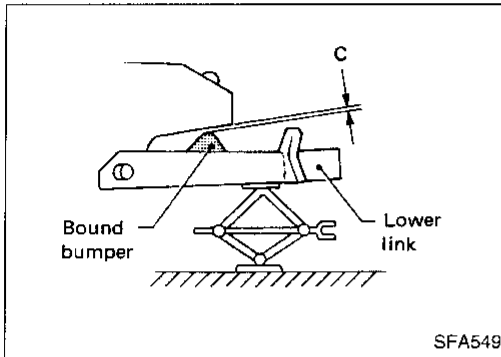

3. Place lower link in the position where bound bumper clearance "C" is 0.

Clearance "C": 0 mm (0 in)

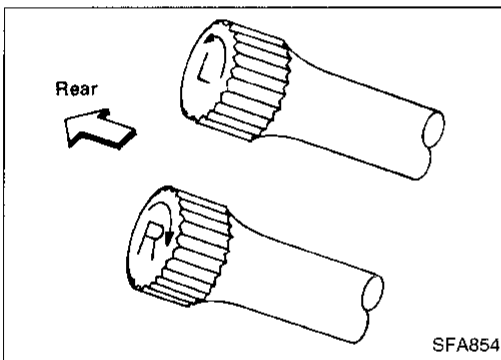

4. Install torsion bar spring. — 2WD —
 - Install torsion bar spring with torque arm. — 4WD —Be sure to install right and left torsion bar springs correctly.

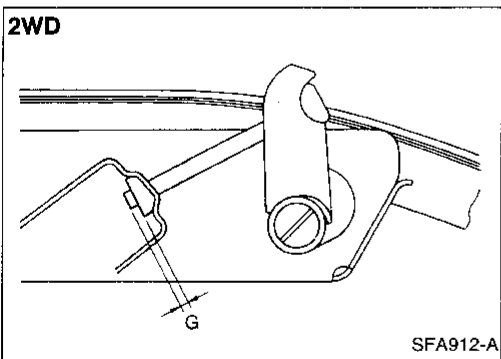

5. Set anchor arm.
Standard length "G":
 - 2WD
6 - 18 mm (0.24 - 0.71 in)
 - 4WD
50 - 60 mm (1.97 - 2.36 in)

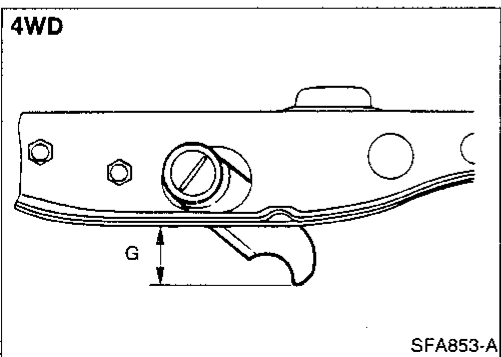

GI
MA
EM
LC
EC
FE
CL
MT
AT
TF
PD
FA
RA
BR
ST
RS
BT
HA
EL
IDX

FRONT SUSPENSION

Torsion Bar Spring (Cont'd)

6. Install snap ring to anchor arm and dust cover.

— 2WD —

Make sure that the snap ring is properly installed on the anchor arm groove.

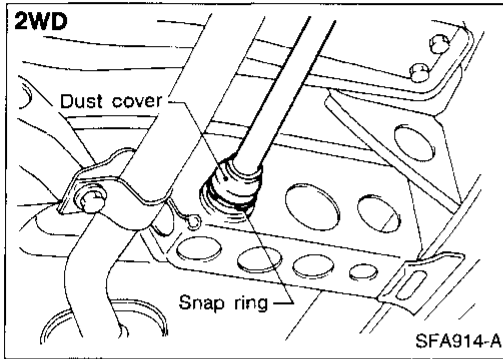

— 4WD —

Make sure that the snap ring and anchor arm are properly installed.

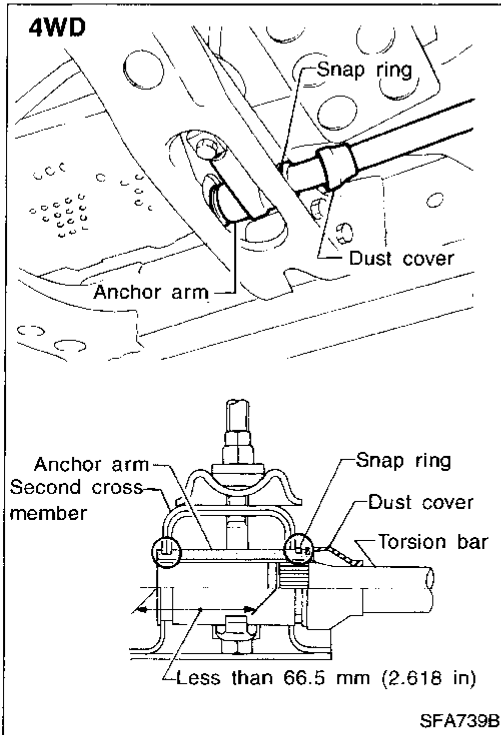

7. Tighten anchor arm adjusting nut to get L dimension.

Standard length "L":

2WD

49 mm (1.93 in)

4WD

77 mm (3.03 in)

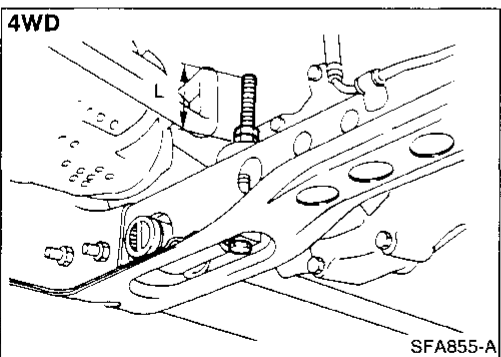
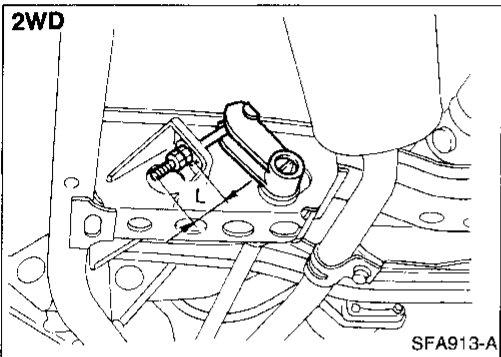

FRONT SUSPENSION

Torsion Bar Spring (Cont'd)

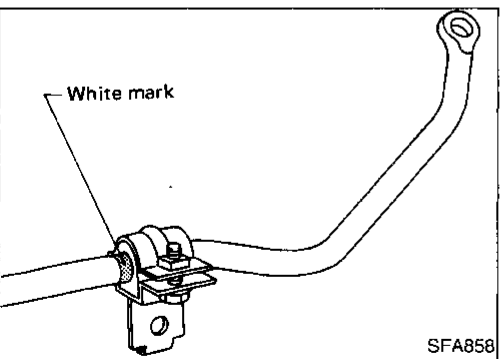
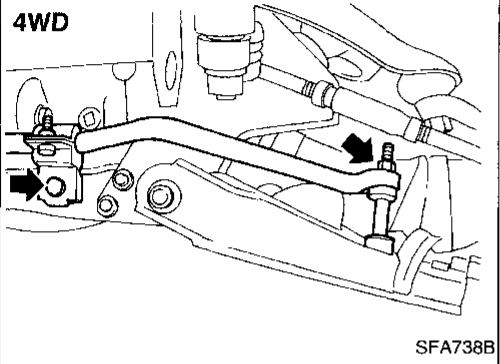
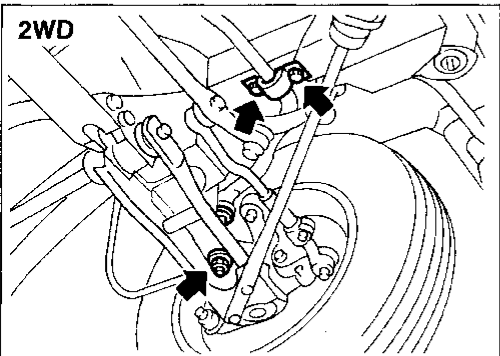
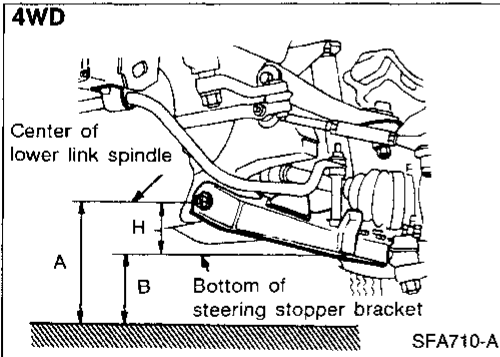
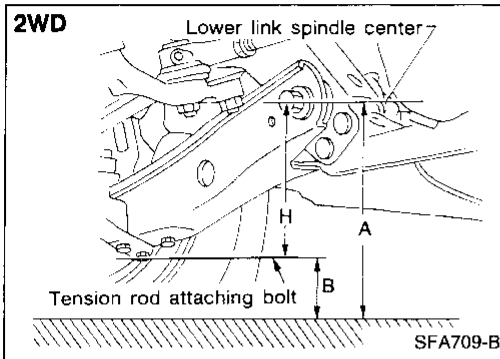

8. Bounce vehicle with tires on ground (Unladen) to eliminate friction of suspension.
9. Measure vehicle posture "H".
 - (1) Exercise the front suspension by bouncing the front of the vehicle 4 or 5 times to ensure that the vehicle is in a neutral height attitude.
 - (2) Measure vehicle posture ... Dimension "H".

H = A - B mm (in) "Unladen"

Refer to WHEEL ALIGNMENT (Unladen) in SDS, FA-46.
10. If height of the vehicle is not within allowable limit, adjust vehicle posture.

Refer to WHEEL ALIGNMENT (Unladen) in SDS, FA-46.
11. Check wheel alignment if necessary.

Refer to WHEEL ALIGNMENT (Unladen) in SDS,FA-46.

Stabilizer Bar

REMOVAL

- Remove stabilizer bar connecting bolts and clamp bolts.

INSPECTION

- Check stabilizer bar for twist and deformation. Replace if necessary.
- Check rubber bushing for cracks, wear and deterioration. Replace if necessary.

INSTALLATION

- Install bushing outside of white mark painted on stabilizer.

GI
MA
EM
LC
FC
FE
CL
MT
AT
TF
PD
FA
RA
BR
ST
RS
BT
HA
EL
IDX

FRONT SUSPENSION

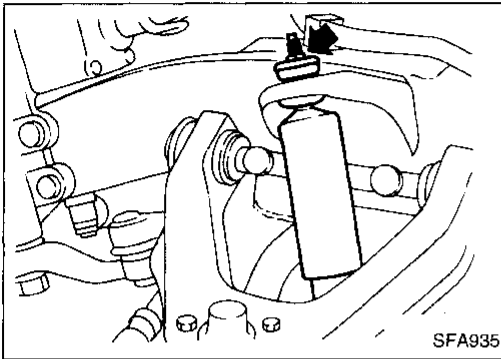

Upper Link

REMOVAL

- Remove shock absorber upper fixing nut.

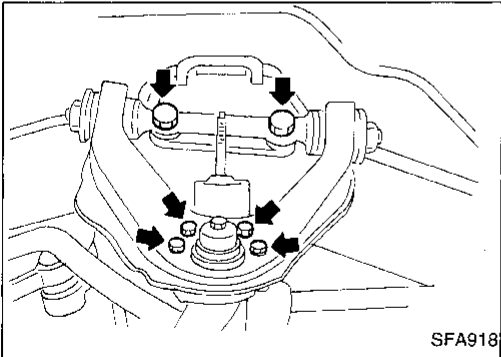

- Remove bolts fixing upper ball joint on upper link.

Support lower link with jack.

- Remove upper link spindle fixing bolts.

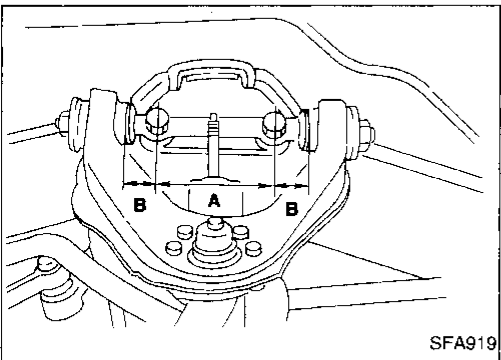

INSTALLATION

- Tighten upper link spindle with camber adjusting shims.
- After fitting, check dimensions "A" and "B".
 - A: 110 mm (4.33 in)
 - B: 32 mm (1.26 in)

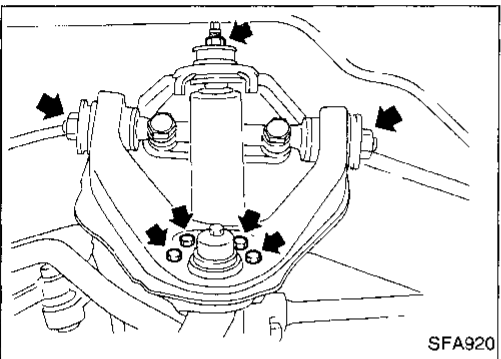

- Install upper ball joint on upper link.
- Install shock absorber upper fixing nut.
- Tighten upper link spindle lock nuts under unladen condition with tires on ground.
- After installing, check wheel alignment. Adjust if necessary. Refer to FA-8.

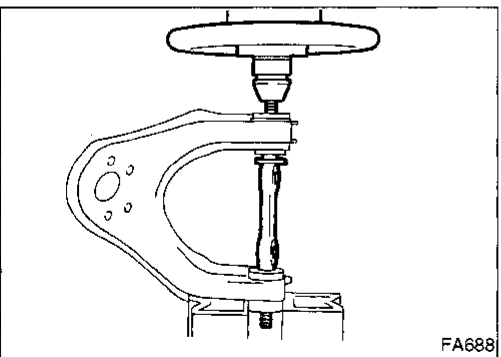

DISASSEMBLY

- Press out upper link spindle with bushings.

INSPECTION

- Check upper link spindle and rubber bushings for damage. Replace if necessary.
- Check upper link for deformation and cracks. Replace if necessary.

FRONT SUSPENSION

Upper Link (Cont'd)

ASSEMBLY

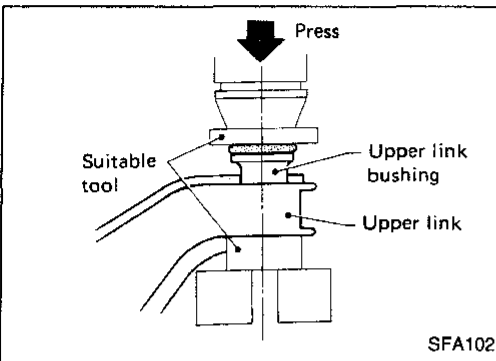

- Apply soapsuds to rubber bushing.
- Press upper link bushing.

Press bushing so that the flange of bushing securely contacts the end surface of the upper link collar.

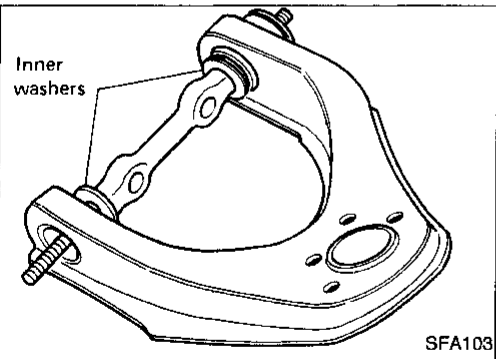

- Insert upper link spindle and inner washers.
- Install inner washers with rounded edges facing inward.**

- Press another bushing.

Press bushing so that the flange of bushing securely contacts the end surface of the upper link collar.

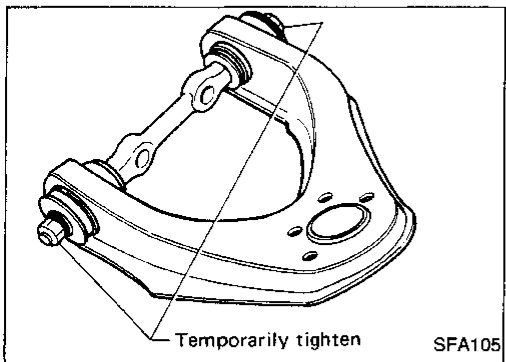

- Temporarily tighten nuts.

GI

MA

EM

LC

EC

FE

CL

MT

AT

TF

PD

FA

RA

BR

ST

RS

BT

HA

EL

IDX

FRONT SUSPENSION

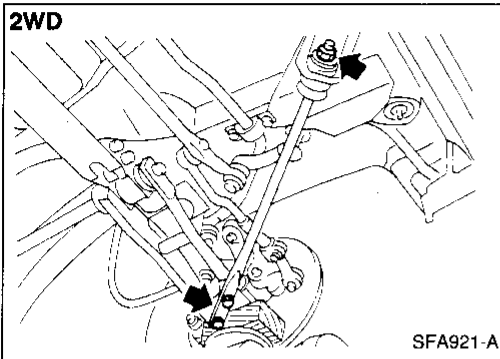

Tension Rod or Compression Rod REMOVAL AND INSTALLATION

- Remove fixing nuts on lower link and frame.
Support lower link with jack.

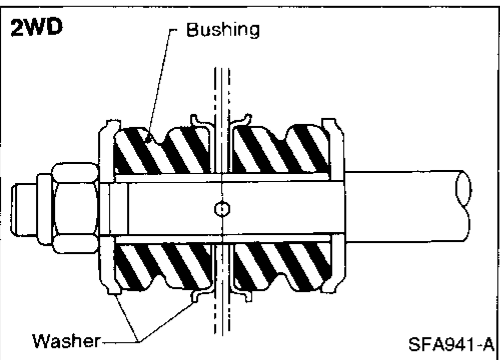
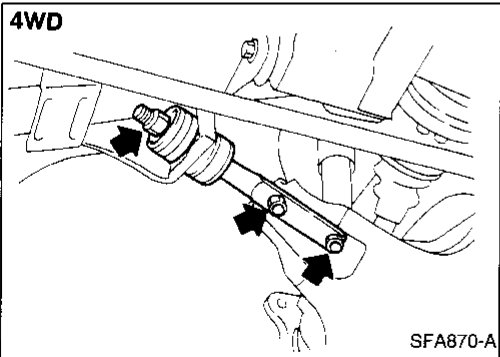

- Install tension rod. — 2WD —
Make sure that the bushings and washers are installed properly.

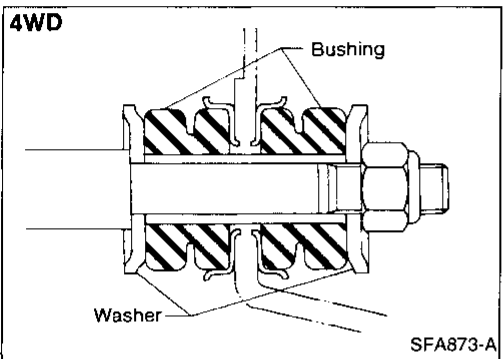

- Install compression rod. — 4WD —
Make sure that the bushings and washers are installed properly.

FRONT SUSPENSION

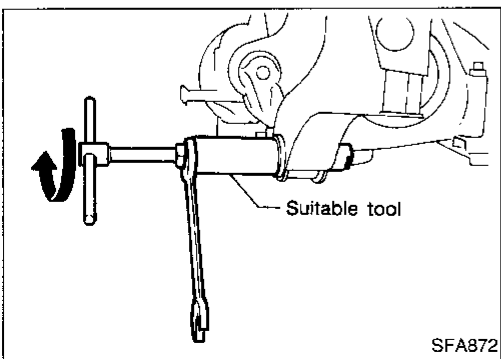
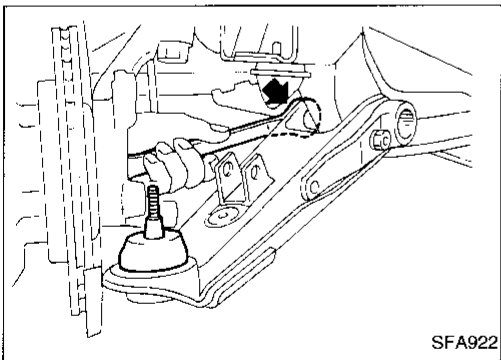
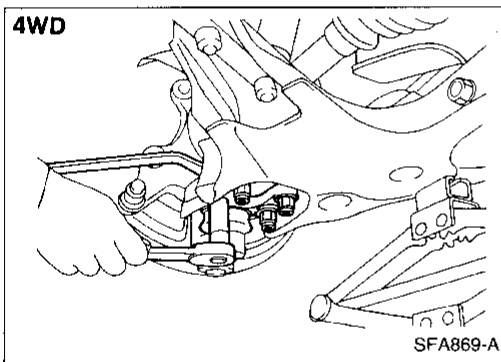
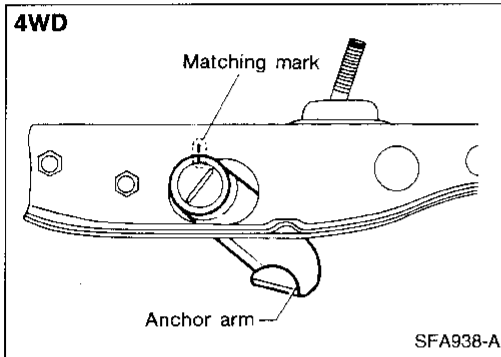
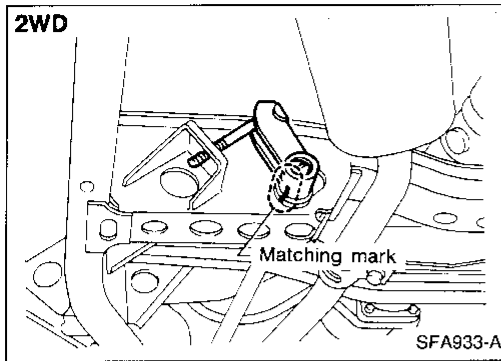

Lower Link

REMOVAL AND INSTALLATION

- Remove torsion bar spring. Refer to REMOVAL in Torsion Bar Spring, FA-36.

Make matching mark on anchor arm and crossmember when loosening adjusting nut until there is no tension on torsion bar spring.

- Separate lower link ball joint from knuckle spindle.
— 2WD —
Refer to FRONT AXLE — Knuckle Spindle, FA-25.
- Separate lower ball joint from lower link. — 4WD —

- Remove front lower link fixing nut.

- Remove bushing of lower link spindle from frame with suitable tool.
- When installing, apply soapy water to bushing.
- After installing lower link, adjust wheel alignment and vehicle height. Refer to FA-8.

INSPECTION

Lower link and lower link spindle

- Check for deformation and cracks. Replace if necessary.

Lower link bushing

- Check for distortion and damage. Replace if necessary.

GI

MA

EM

LC

EC

FE

CL

MT

AT

TF

PD

FA

RA

BR

ST

RS

BT

HA

EL

IDX

FRONT SUSPENSION

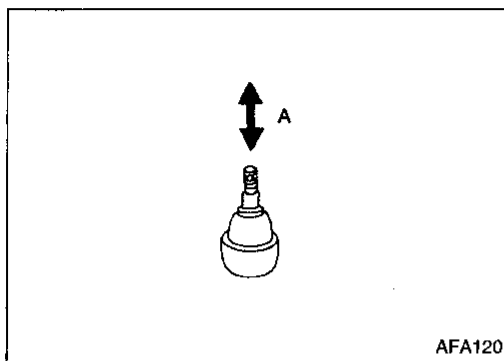

Upper Ball Joint and Lower Ball Joint

REMOVAL AND INSTALLATION

- Separate knuckle spindle from upper and lower links.
Refer to FRONT AXLE — Knuckle Spindle, FA-25.

INSPECTION

- Check ball joint for vertical end play “A”.

Upper ball joint:

0.1 - 1.4 mm (0.004 - 0.055 in)

Lower ball joint:

2WD

0.1 - 1.3 mm (0.004 - 0.051 in)

4WD

0.7 mm (0.028 in) or less

Replace ball joint if movement is beyond specifications.

- Check dust cover for damage.
Replace dust cover and dust cover clamp if necessary.

SERVICE DATA AND SPECIFICATIONS (SDS)

General Specifications

TORSION BAR SPRING

| Applied model | 2WD | 4WD |
|--|----------------------------|------------------------------|
| Spring diameter x length mm (in) | 22.6 x 885 (0.890 x 34.84) | 26.0 x 1,205 (1.024 x 47.44) |
| Spring constant N/mm (kg/mm, lb/in) | 16.5 (1.68, 94.1) | 25.7 (2.62, 146.7) |

SHOCK ABSORBER

| Applied model | 2WD | | 4WD | |
|--|-----------------------------------|---|---|---|
| | Except Heavy duty | Heavy duty | U.S.A. | Canada |
| Shock absorber type | Non-adjustable | | | |
| Damping force [at 0.3 m (1.0 ft)/sec.] N (kg, lb) | | | | |
| Expansion | 579 - 794 (59 - 81, 130 - 179) | 1,089 - 1,461 (111 - 149, 245 - 329) | 1,599 - 2,128 (163 - 217, 359 - 478) | 1,687 - 2,236 (172 - 228, 379 - 503) |
| Compression | 216 - 333 (22 - 34, 49 - 75) | 314 - 471 (32 - 48, 71 - 106) | 559 - 814 (57 - 83, 126 - 183) | 432 - 647 (44 - 66, 97 - 146) |

STABILIZER BAR

| Applied model | 2WD | 4WD |
|------------------------------------|--------------|--------------|
| Stabilizer bar diameter mm (in) | 23.0 (0.906) | 26.0 (1.024) |

TENSION ROD OR COMPRESSION ROD

| Applied model | 2WD | 4WD |
|----------------------|--------------|--------------|
| Rod diameter mm (in) | 22.0 (0.866) | 23.5 (0.925) |

DRIVE SHAFT (4WD)

| | |
|---|-------------------------------------|
| Drive shaft joint type | |
| Final drive side | TS82F |
| Wheel side | ZF100 |
| Fixed joint axial end play limit mm (in) | 1 (0.04) |
| Diameter mm (in) | |
| Wheel side (D ₁) | 29.0 (1.142) |
| Grease | |
| Quality | Nissan genuine grease or equivalent |
| Capacity g (oz) | |
| Final drive side | 95 - 105 (3.35 - 3.70) |
| Wheel side | 135 - 145 (4.76 - 5.11) |
| Boot length mm (in) | |
| Final drive side (L ₁) | 95 - 97 (3.74 - 3.82) |
| Wheel side (L ₂) | 96 - 98 (3.78 - 3.86) |

Final drive side

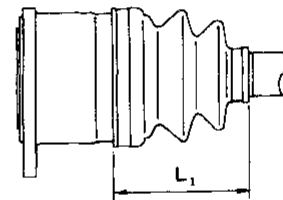

Wheel side

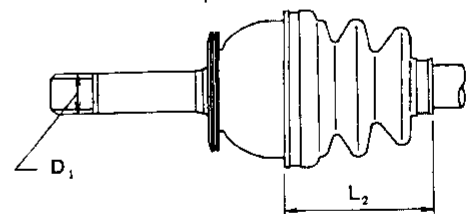

SFA877A

SERVICE DATA AND SPECIFICATIONS (SDS)

Inspection and Adjustment

WHEEL ALIGNMENT (Unladen*1)

2WD

| | | ALLOWABLE LIMIT | ADJUSTING RANGE | |
|-----------------------------|---------------------------|-------------------------|---|-----------------|
| Camber | Minimum | -0°20' (-0.33°) | -0°05' (-0.08°) | |
| | Nominal | 0°25' (0.42°) | 0°25' (0.42°) | |
| | Maximum | 1°10' (1.17°) | 0°55' (0.92°) | |
| | Left and right difference | 45' (0.75°) or less | | |
| Caster | Minimum | -0°23' (-0.38°) | -0°08' (-0.13°) | |
| | Nominal | 0°22' (0.37°) | 0°22' (0.37°) | |
| | Maximum | 1°07' (1.12°) | 0°52' (0.87°) | |
| | Left and right difference | 45' (0.75°) or less | | |
| Kingpin inclination | Minimum | 8°20' (8.33°) | 8°35' (8.58°) | |
| | Nominal | 9°05' (9.08°) | 9°05' (9.08°) | |
| | Maximum | 9°50' (9.83°) | 9°35' (9.58°) | |
| Total toe-in | Minimum | 1 (0.04) | 2 (0.08) | |
| | Nominal | 3 (0.12) | 3 (0.12) | |
| | Maximum | 5 (0.20) | 4 (0.16) | |
| Distance (A - B) mm (in) | Minimum | 5' (0.08°) | 10' (0.17°) | |
| | Nominal | 15' (0.25°) | 15' (0.25°) | |
| | Maximum | 25' (0.42°) | 20' (0.33°) | |
| Angle (left plus right) | Minimum | 34°00' (34.00°) | 36°00' (36.00°) | |
| | Nominal | 38°00' (38.00°) | 38°00' (38.00°) | |
| | Maximum | 38°00' (38.00°) | 38°00' (38.00°) | |
| Wheel turning angle | Inside | Minimum | 31°00' (31.00°) | 33°00' (33.00°) |
| | | Nominal | 35°00' (35.00°) | 35°00' (35.00°) |
| | | Maximum | 35°00' (35.00°) | 35°00' (35.00°) |
| | Outside | Minimum | 31°00' (31.00°) | 33°00' (33.00°) |
| | | Nominal | 35°00' (35.00°) | 35°00' (35.00°) |
| | | Maximum | 35°00' (35.00°) | 35°00' (35.00°) |
| Full turn*2 | Minimum | 108 - 118 (4.25 - 4.65) | 111 - 115 (4.37 - 4.53) | |
| | Maximum | 108 - 118 (4.25 - 4.65) | 111 - 115 (4.37 - 4.53) | |
| Vehicle posture | | | | |
| Lower arm pivot height (H) | | mm (in) | 108 - 118 (4.25 - 4.65) 111 - 115 (4.37 - 4.53) | |

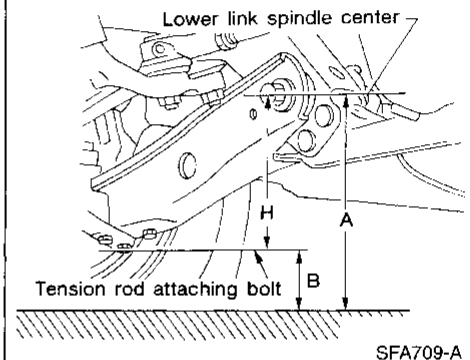

*1: Fuel, radiator coolant and engine oil full. Spare tire, jack, hand tools and mats in designated positions.

*2: On power steering models, wheel turning force (at circumference of steering wheel) of 98 to 147 N (10 to 15 kg, 22 to 33 lb) with engine idle.

SERVICE DATA AND SPECIFICATIONS (SDS)

Inspection and Adjustment (Cont'd)

4WD

| | | ALLOWABLE LIMIT | ADJUSTING RANGE |
|----------------------------|--|---------------------------|-----------------------|
| Camber | Degree minute (Decimal degree) | Minimum | -0°05' (-0.08°) |
| | | Nominal | 0°40' (0.67°) |
| | | Maximum | 1°25' (1.42°) |
| | | Left and right difference | 45' (0.75°) or less |
| Caster | Degree minute (Decimal degree) | Minimum | 0°33' (0.55°) |
| | | Nominal | 1°18' (1.30°) |
| | | Maximum | 2°03' (2.05°) |
| | | Left and right difference | 45' (0.75°) or less |
| Kingpin inclination | Degree minute (Decimal degree) | Minimum | 7°21' (7.35°) |
| | | Nominal | 8°06' (8.10°) |
| | | Maximum | 8°51' (8.85°) |
| Total toe-in | Distance (A - B) mm (in) | Minimum | 2 (0.08) |
| | | Nominal | 4 (0.16) |
| | | Maximum | 6 (0.24) |
| | Angle (left plus right) Degree minute (Decimal degree) | Minimum | 9' (0.15°) |
| | | Nominal | 19' (0.32°) |
| | | Maximum | 29' (0.48°) |
| Wheel turning angle | Inside Full turn*2 Degree minute (Decimal degree) | Minimum | 31°00' (31.00°) |
| | | Nominal | 35°00' (35.00°) |
| | | Maximum | 35°00' (35.00°) |
| | Outside Degree minute (Decimal degree) | Minimum | 29°00' (29.00°) |
| | | Nominal | 31°00' (31.00°) |
| | | Maximum | 33°00' (33.00°) |
| Vehicle posture | | | |
| Lower arm pivot height (H) | mm (in) | 41 - 51 (1.61 - 2.01) | 44 - 48 (1.73 - 1.89) |

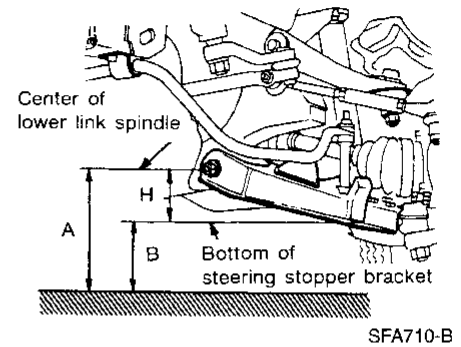

*1: Fuel, radiator coolant and engine oil full. Spare tire, jack, hand tools and mats in designated positions.

*2: On power steering models, wheel turning force (at circumference of steering wheel) of 98 to 147 N (10 to 15 kg, 22 to 33 lb) with engine idle.

SERVICE DATA AND SPECIFICATIONS (SDS)

Inspection and Adjustment (Cont'd)

WHEEL BEARING

2WD

| | |
|--|--------------------------------------|
| Wheel bearing axial end play mm (in) | 0 (0) |
| Wheel bearing lock nut Tightening torque N-m (kg-m, ft-lb) | 34 - 39 (3.5 - 4.0, 25 - 29) |
| Return angle degree | 45° - 60° |
| Wheel bearing starting torque At wheel hub bolt With new grease seal N (kg, lb) | 9.8 - 28.4 (1.0 - 2.9, 2.2 - 6.4) |
| With used grease seal N (kg, lb) | 9.8 - 23.5 (1.0 - 2.4, 2.2 - 5.3) |

4WD

| | |
|---|--|
| Wheel bearing lock nut Tightening torque N-m (kg-m, ft-lb) | 78 - 98 (8 - 10, 58 - 72) |
| Retightening torque after loosening wheel bearing lock nut N-m (kg-m, ft-lb) | 0.5 - 1.5 (0.05 - 0.15, 0.4 - 1.1) |
| Axial end play mm (in) | 0 (0) |
| Starting force at wheel hub bolt N (kg, lb) | A |
| Turning angle degree | 15° - 30° |
| Starting force at wheel hub bolt N (kg, lb) | B |
| Wheel bearing preload at wheel hub bolt N (kg, lb) B - A | 7.06 - 20.99 (0.72 - 2.14, 1.59 - 4.72) |

WHEEL RUNOUT AVERAGE*

| Wheel type | Aluminum | Steel | | |
|---------------------------------|----------------|----------------|----------------|----------------|
| | | 15 inches | 14 inches | |
| | | | Painted | Plated |
| Radial runout limit mm (in) | 0.3 (0.012) | 0.8 (0.031) | 0.5 (0.020) | 0.6 (0.024) |
| Lateral runout limit mm (in) | 0.3 (0.012) | 0.8 (0.031) | 0.8 (0.031) | 0.8 (0.031) |

* Wheel runout average = (Outside runout value + Inside runout value) x 0.5

DRIVE SHAFT (4WD)

| | |
|---------------------------------------|-----------------------|
| Drive shaft axial end play mm (in) | 0.45 (0.0177) or less |
|---------------------------------------|-----------------------|

Drive shaft end snap ring

| Thickness mm (in) | Part No. |
|-------------------|-------------|
| 1.1 (0.043) | 39253-88G10 |
| 1.3 (0.051) | 39253-88G11 |
| 1.5 (0.059) | 39253-88G12 |
| 1.7 (0.067) | 39253-88G13 |
| 1.9 (0.075) | 39253-88G14 |
| 2.1 (0.083) | 39253-88G15 |
| 2.3 (0.091) | 39253-88G16 |

UPPER BALL JOINT

| | |
|--|---------------------------|
| Vertical end play limit "A" mm (in) | 0.1 - 1.4 (0.004 - 0.055) |
|--|---------------------------|

LOWER BALL JOINT

| Applied model | 2WD | 4WD |
|--|------------------------------|------------------------|
| Vertical end play limit "A" mm (in) | 0.1 - 1.3 (0.004 - 0.051) | 0.7 (0.028) or less |