

# HARBORFRONT

## BODY & TRIM



**SECTION BT**

**CONTENTS**

<b>PRECAUTIONS</b> .....	2	<b>SUNROOF</b> .....	25
Supplemental Restraint System (SRS) "AIR BAG" .....	2	Service Procedure .....	25
<b>GENERAL SERVICING</b> .....	3	<b>WINDSHIELD AND WINDOWS</b> .....	26
Clip and Fastener .....	3	Windshield .....	27
<b>BODY END</b> .....	6	Back Window .....	28
Front End .....	6	Rear Side Window .....	29
Rear End.....	7	<b>MIRROR</b> .....	30
Step Bumper.....	8	Door Mirror.....	30
<b>DOOR</b> .....	9	Rearview Mirror .....	31
Front Door.....	9	<b>CAB AND REAR BODY</b> .....	32
<b>INSTRUMENT PANEL</b> .....	10	Removal .....	32
<b>INTERIOR TRIM</b> .....	13	Cab Body .....	32
Side and Floor Trim — Passenger room .....	13	Rear Body .....	32
Roof Trim .....	15	Body Mounting.....	33
<b>EXTERIOR</b> .....	17	<b>BODY ALIGNMENT</b> .....	34
<b>SEAT</b> .....	23	Engine Compartment.....	35
Front Seat.....	23	Underbody .....	36
Jump Seat — King Cab Model.....	24		

- ★ For seat belt, refer to MA and RS section.
- ★ For wiring diagrams of body electrical systems, refer to EL section.

GI  
MA  
EM  
LC  
EC  
FE  
CL  
MT  
AT  
TF  
PD  
FA  
RA  
BR  
ST  
RS  
BT  
HA  
EL  
IDX

## PRECAUTIONS

- When removing or installing various parts, place a cloth or padding on the vehicle body to prevent scratches.
- Handle trim, molding, instruments, grille, etc., carefully during removal or installation. Be careful not to soil or damage them.
- Apply sealing compound where necessary when installing parts.
- When applying sealing compound, be careful that the sealing compound does not protrude from parts.
- When replacing any metal parts (for example, body outer panel, members, etc.), be sure to take rust prevention measures.

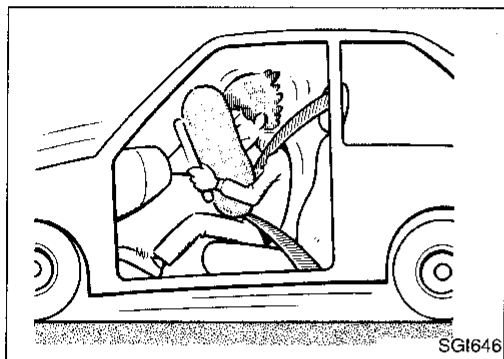

### Supplemental Restraint System (SRS) "AIR BAG"







The Supplemental Restraint System "Air Bag", used along with a seat belt, helps to reduce the risk or severity of injury to the driver in a frontal collision. The Supplemental Restraint System consists of an air bag module (located in the center of the steering wheel), a diagnosis sensor unit, warning lamp, wiring harness, a crash zone sensor (4WD models) and spiral cable. Information necessary to service the system safely is included in the **RS** section of this Service Manual.

#### WARNING:

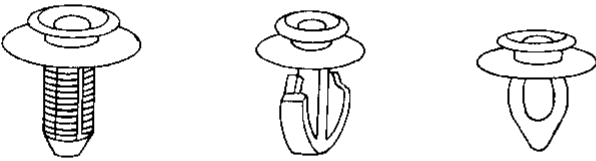
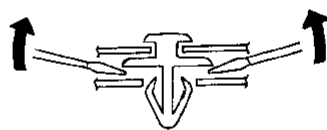
- To avoid rendering the SRS inoperative, which could increase the risk of personal injury or death in the event of a collision which would result in air bag inflation, all maintenance must be performed by an authorized NISSAN dealer.
- Improper maintenance, including incorrect removal and installation of the SRS, can lead to personal injury caused by unintentional activation of the system.
- Do not use electrical test equipment on any circuit related to the SRS unless instructed to in this Service Manual. SRS wiring harnesses are covered with yellow insulation either just before the harness connectors or for the complete harness, for easy identification.

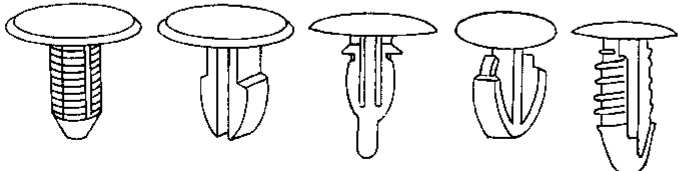
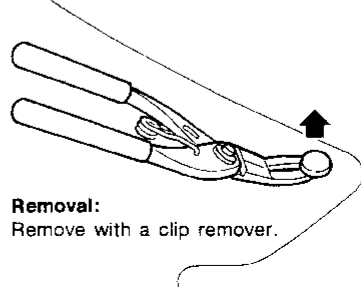
## Clip and Fastener

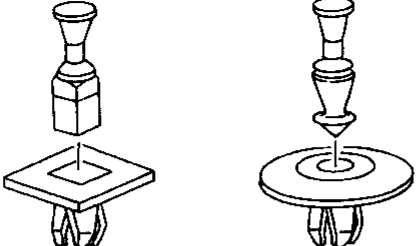
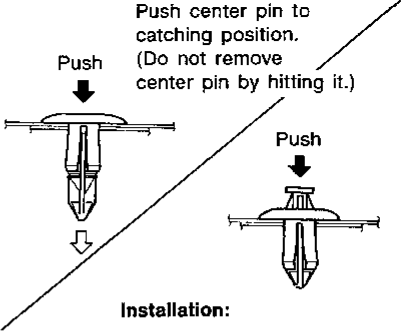

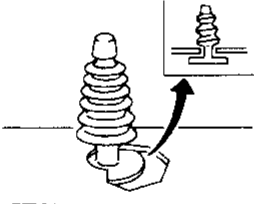
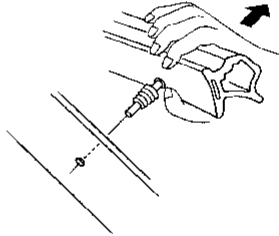



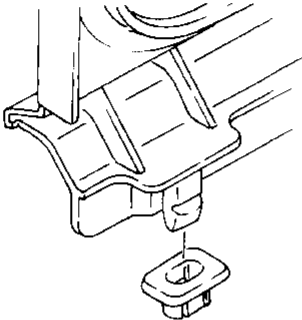
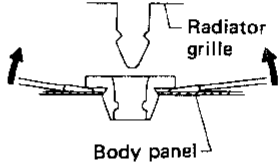

- Clips and fasteners in BT section correspond to the following numbers and symbols.
- Replace any clips and/or fasteners which are damaged during removal or installation.

Symbol No.	Shapes	Removal & Installation
	 <p style="text-align: right;">SBF302H                      SBF367BA</p>	<p><b>Removal:</b> Remove by bending up with flat-bladed screwdrivers or clip remover.</p> 
	 <p style="text-align: right;">SBF303H                      SBF423H</p>	<p><b>Removal:</b> Remove with a clip remover.</p> 
	 <p style="text-align: right;">SBF258G                      SBF708E</p>	<p><b>Installation:</b></p> <p>Push center pin to catching position. (Do not remove center pin by hitting it.)</p> 
	 <p style="text-align: right;">SBF104B                      SBF147B</p>	<p><b>Removal:</b></p> 

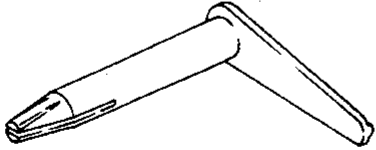
CI  
 MA  
 EM  
 LC  
 EC  
 FE  
 CL  
 WT  
 AT  
 TF  
 PD  
 FA  
 RA  
 BR  
 ST  
 RS  
**BT**  
 HA  
 EL  
 DX

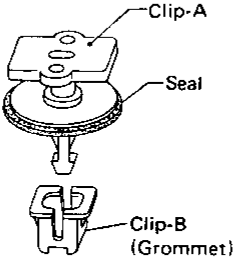
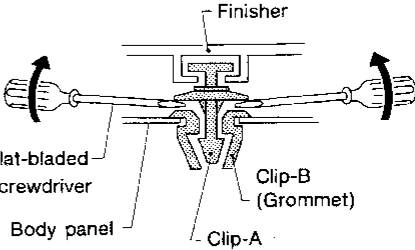

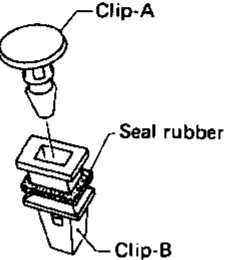
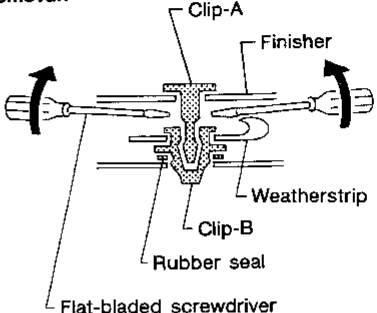

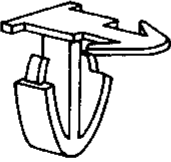
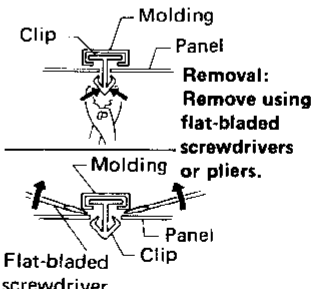
# GENERAL SERVICING

## Clip and Fastener (Cont'd)

Symbol No.	Shapes	Removal & Installation
		<p><b>Removal:</b> Remove by bending up with flat-bladed screwdrivers.</p>  <p style="text-align: right;">SBF351C <span style="margin-left: 200px;">SBF352C</span></p>
	 <p style="text-align: right;">SBF353C</p>	
	 <p style="text-align: right;">SBF651B</p>	<p><b>Removal:</b></p>  <p style="text-align: right;">SBF652B</p>
	 <p style="text-align: right;">SBF648B</p>	<p><b>Removal:</b></p>  <p style="text-align: right;">SBF649B</p>
	 <p style="text-align: right;">SBF317C</p>	 <p style="text-align: right;">SBF571B</p>

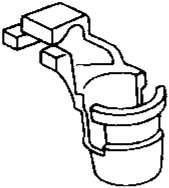
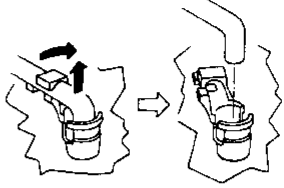
# GENERAL SERVICING

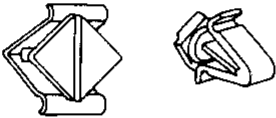
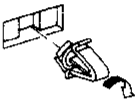
## Clip and Fastener (Cont'd)

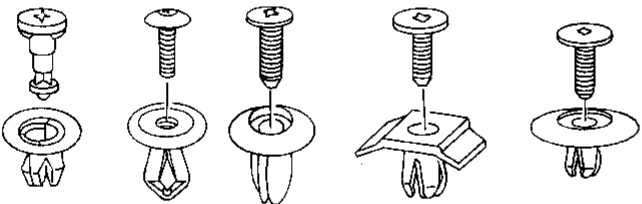
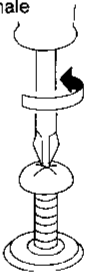
Symbol No.	Shapes	Removal & Installation
		<p><b>Removal:</b> Holder portion of clip must be spread out to remove rod.</p>  <p style="text-align: right;">SBF770B</p>
		<p><b>Removal:</b> Rotate 45° to remove.</p> <p><b>Installation:</b></p>  <p><b>Removal:</b></p>  <p style="text-align: right;">SBF085B</p>
		<p><b>Removal:</b></p> <ol style="list-style-type: none"> <li>1. Screw out with a Phillips screwdriver.</li> <li>2. Remove female portion with flat-bladed screwdriver.</li> </ol>  <p style="text-align: right;">SBF992G</p>

GI  
MA  
EM  
LC  
EC  
FE  
CL  
MT  
AT  
TF  
PD  
FA  
RA  
BR  
ST  
RS  
BT  
HA  
EL  
DX

## Front End

- Hood adjustment: Adjust at hinge portion.
- Hood lock adjustment: After adjusting, check hood lock control operation. Apply a coat of grease to hood lock engaging mechanism.
- Hood opener: Do not attempt to bend cable forcibly. Doing so could increase effort required to unlock hood.
- Bumper finisher: It is made of plastic. Do not use excessive force and keep oil away from it.

SEC. 260•261•262•620•623•650•656

### Hood lock adjustment

- Adjust hood so that hood primary lock meshes at a position where hood is 1 to 1.5 mm (0.039 to 0.059 in) lower than fender.
- After hood lock adjustment, adjust bumper rubber.
- When securing hood lock, ensure it does not tilt. Striker must be positioned at the center of hood primary lock.
- After adjustment, ensure that hood primary and secondary lock operate properly.

### Hood lock secondary latch hooking length

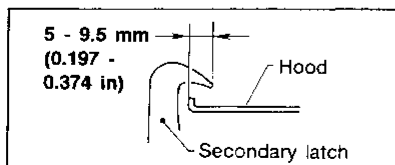

- ### Bumper rubber adjustment
- Adjust so that hood is aligned with fender.  
[Bumper rubber free height is approx. 19 mm (0.75 in).]

### Hood hinge

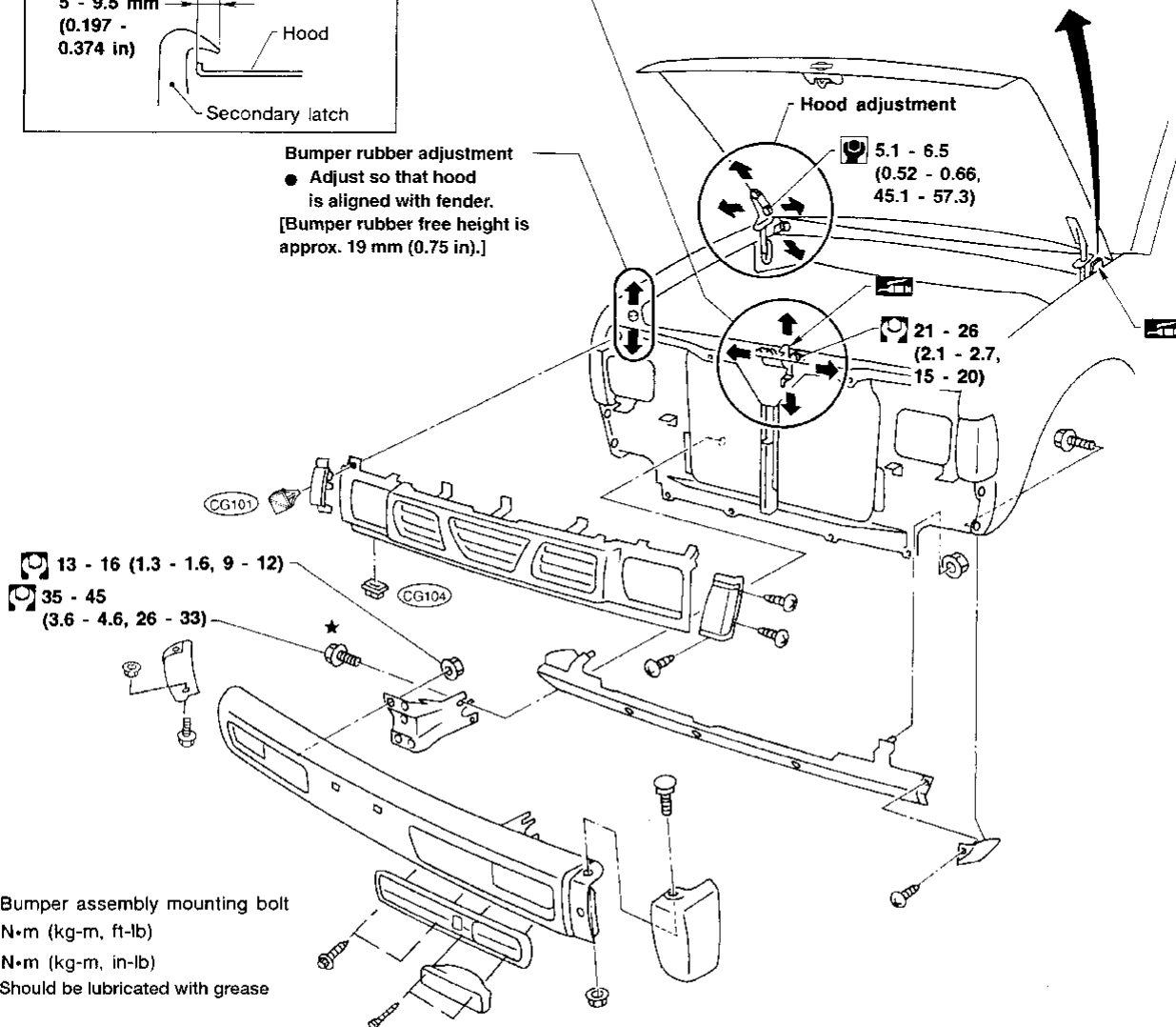
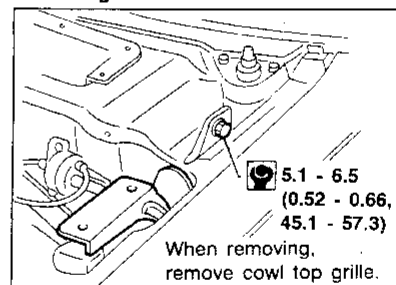

- ★ : Bumper assembly mounting bolt
- : N·m (kg-m, ft-lb)
- : N·m (kg-m, in-lb)
- : Should be lubricated with grease

# BODY END

## Rear End

SEC. 930A • 940A

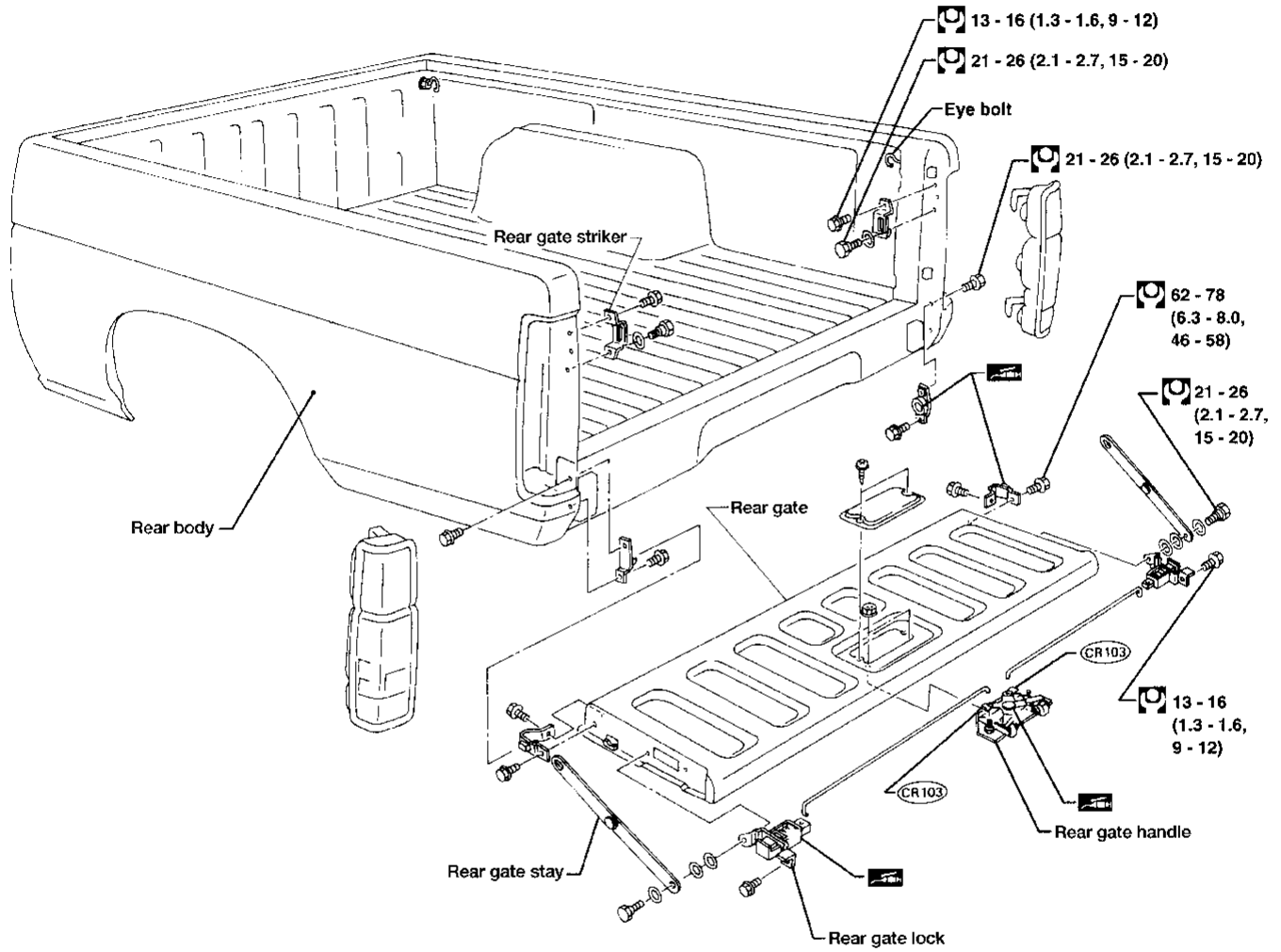

GI  
MA  
EM  
LC  
EC  
FE  
CL  
MT  
AT  
TF  
PD  
FA  
RA  
BR  
ST  
RS  
BT  
HA  
EL  
IDX

: N · m (kg-m, ft-lb)

: Should be lubricated with grease

ABT152

# BODY END

## Step Bumper

SEC. 850

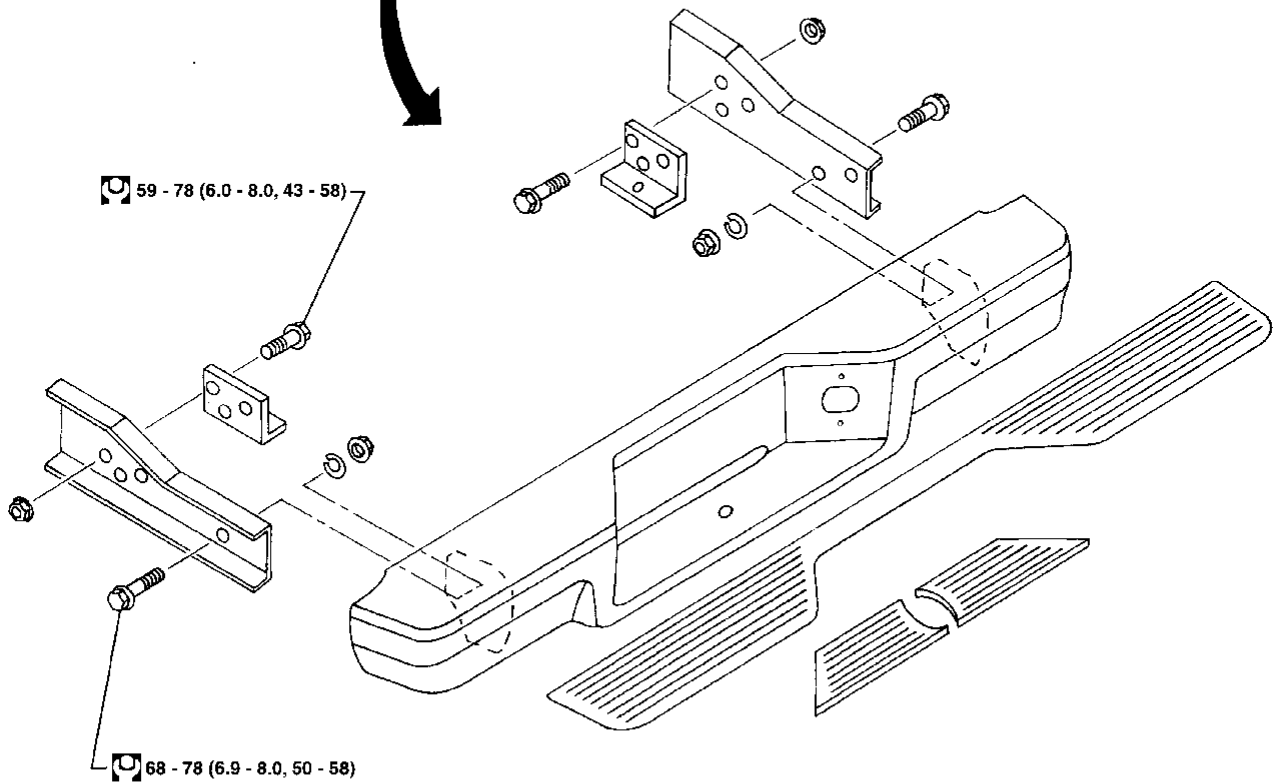
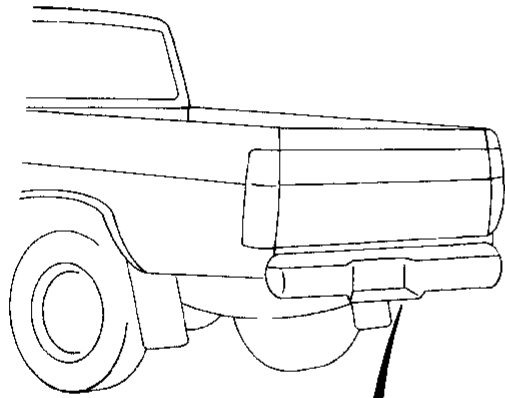

 : N·m (kg-m, ft-lb)

ABT163

# DOOR

## Front Door

- For removal of door trim, refer to "INTERIOR TRIM", BT-13.
- After adjusting door lock, check door lock operation.

SEC. 800-803-805

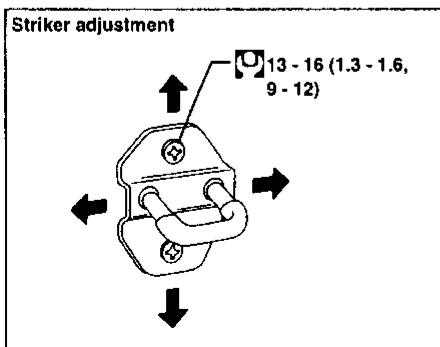
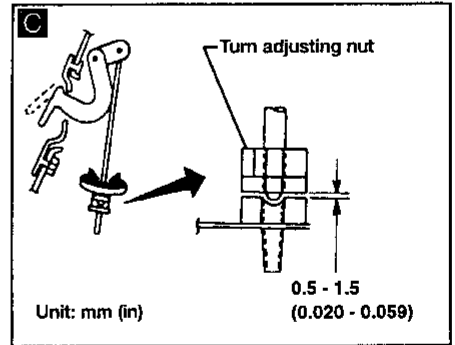
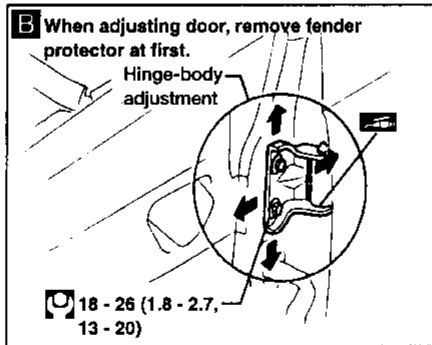
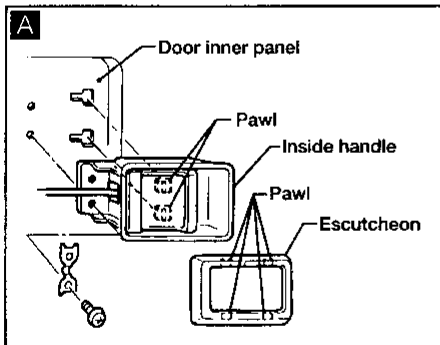
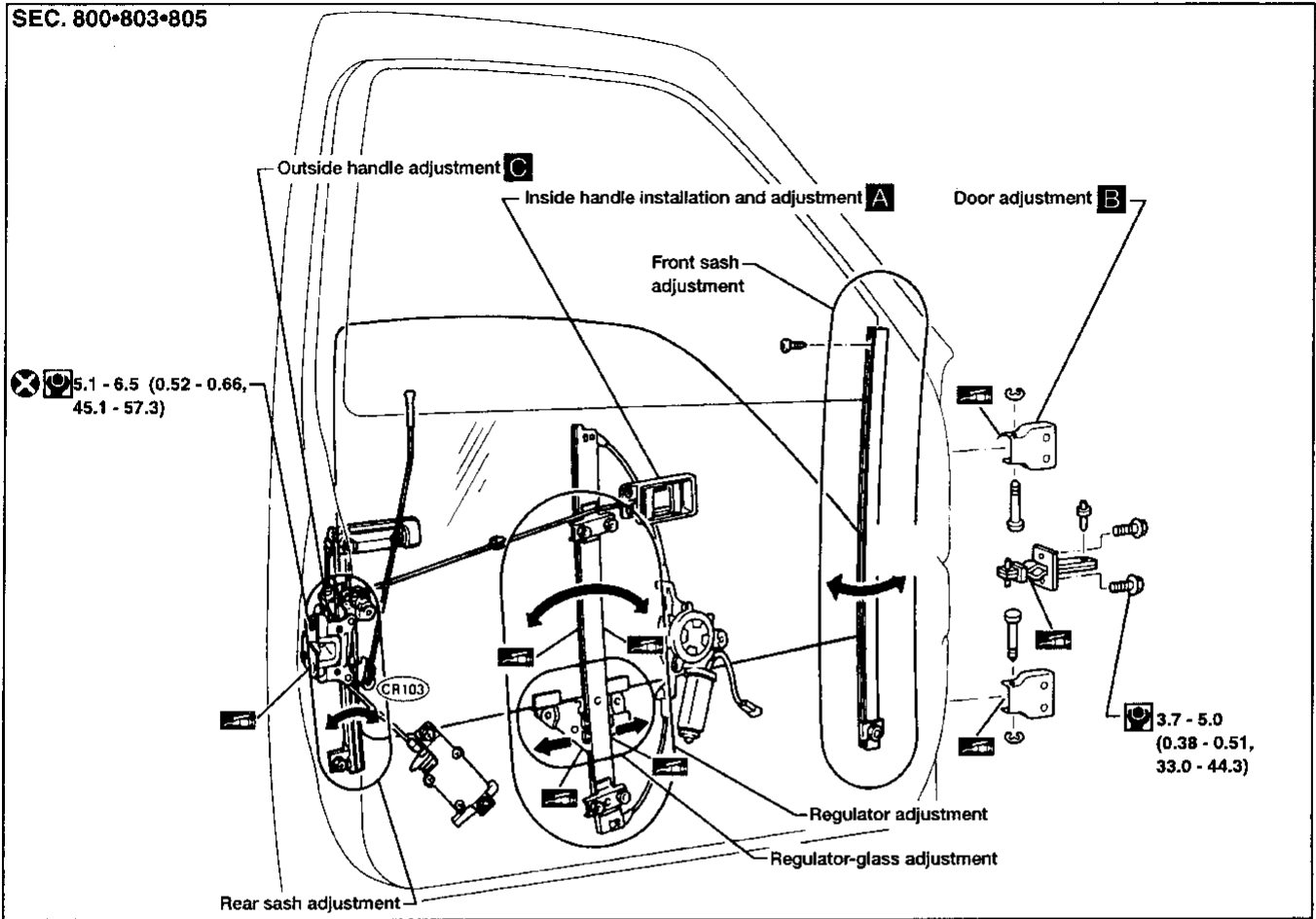

: N·m (kg-m, in-lb)

: N·m (kg-m, ft-lb)

: Should be lubricated with grease

GI  
MA  
EM  
LC  
EC  
FE  
CL  
MT  
AT  
TF  
PD  
FA  
RA  
BR  
ST  
RS  
BT  
HA  
EL  
IDX

# INSTRUMENT PANEL

**CAUTION:**

- Disconnect both terminals from battery in advance.
- Disconnect air bag module connector in advance.
- Be careful not to scratch finishers and other parts.
- Never tamper with or force air bag lid open, as this may adversely affect air bag performance.

**REMOVAL — Instrument panel assembly**

Instrument panel assembly	Combination meter	Audio control	Heater and A/C control	Console box
Remove air bag module and steering wheel. Refer to RS and ST sections.				
① Steering column cover ● Remove four screws.				
② Instrument lower panel driver side ● Remove two screws. <span style="float: right;">C</span>				
③ Cluster lid A ● Remove four screws.				
④ Combination meter ● Remove four screws, then disconnect harness connectors.				
⑤ Glove box assembly ● Remove six screws and two pins.				
⑥ Instrument lower panel passenger side ● Remove one screw.				
Remove ashtray				
⑦ Cluster lid C ● Remove two screws, then disconnect harness connectors. <span style="float: right;">E</span>				
⑧ Audio and deck pocket ● Remove four screws, then disconnect harness connectors.				
⑨ Heater and A/C control ● Remove mask and two screws. ● Disconnect temperature control cable and harness connectors.				
⑩ Instrument stay cover lower center ● Remove two screws. <span style="float: right;">D</span>				
⑪ Instrument lower panel center ● Remove six screws.				
⑫ Ventilator grille driver side ● Remove one screw. <span style="float: right;">B</span>				
⑬ Defroster grille ● Remove three grilles. <span style="float: right;">A</span>				
Remove left and right front pillar garnishes.				
⑭ Instrument panel assembly ● Remove nine screws and bolts marked*.				
⑮ Center console ● Remove five screws.				
⑯ A/T finisher ● Remove four screws, then disconnect harness connector.				

**INSTALLATION**

Reverse the procedures described above.

**Pay attention so as not to scratch the parts (plastic). During installation, fit the ducting parts exactly.**

# INSTRUMENT PANEL

SEC. 272•280•680•685•969

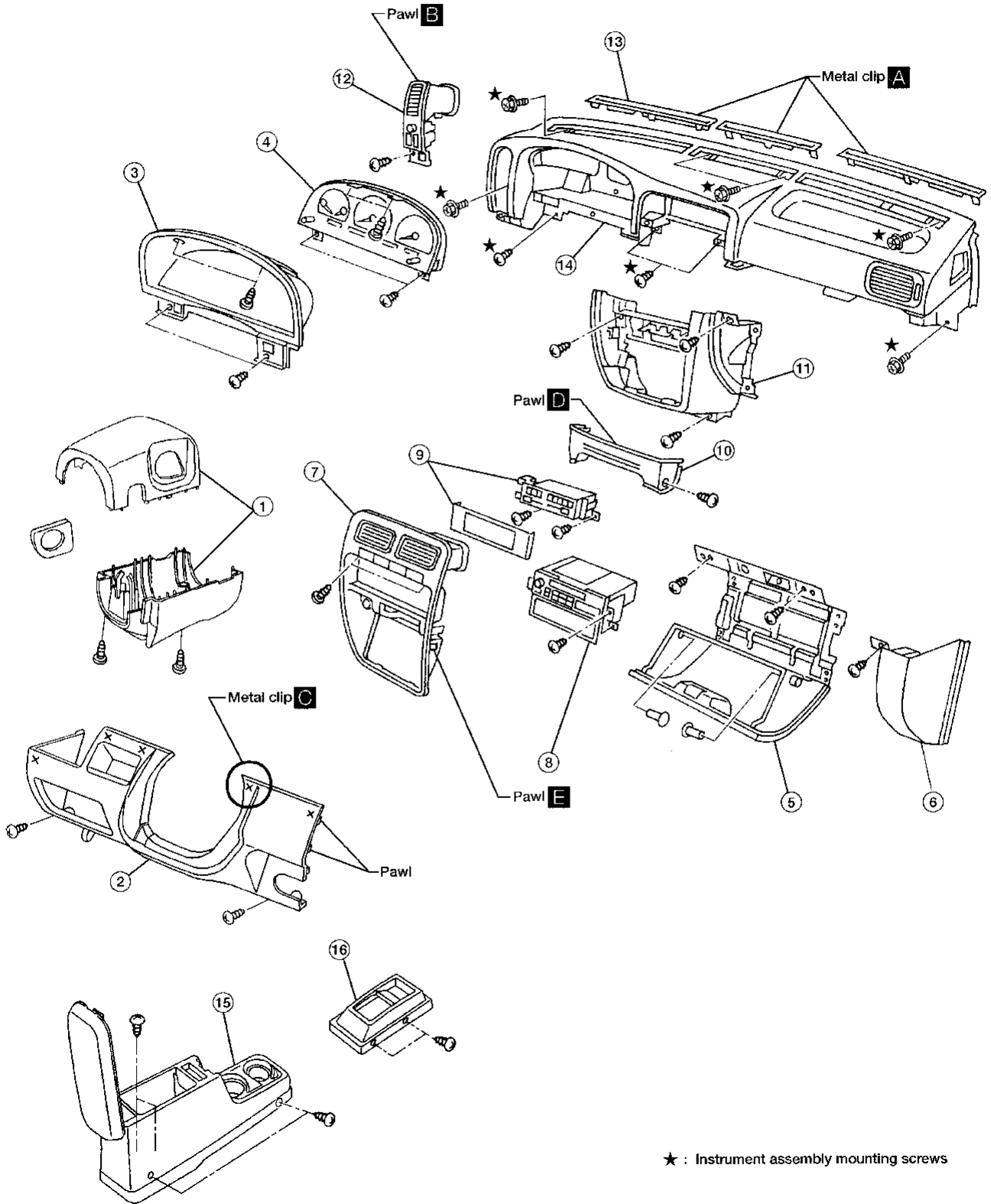

★ : Instrument assembly mounting screws

GI  
MA  
EM  
LC  
EC  
FE  
CL  
MT  
AT  
TF  
PD  
FA  
RA  
BR  
ST  
RS  
BT  
HA  
EL  
IDX

# INSTRUMENT PANEL

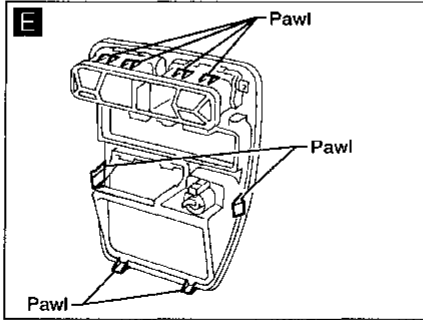
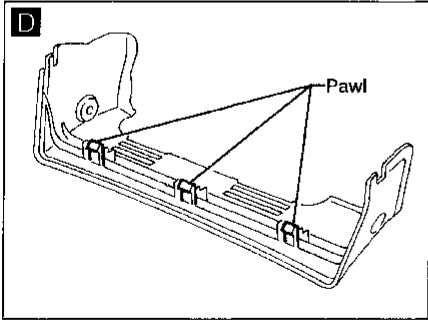
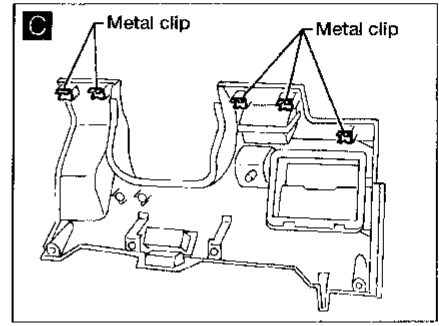
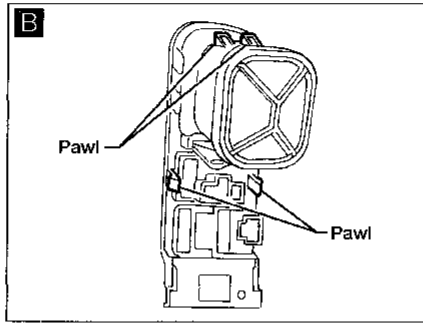
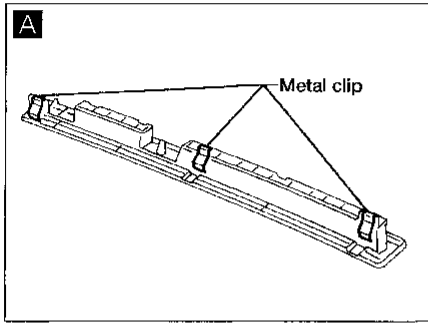

ABT155

# INTERIOR TRIM

## Side and Floor Trim — Passenger room

- Wrap the tip of flat-bladed screwdriver with a cloth when removing metal clips from garnish.
- When handling interior or exterior parts, do not use excessive force and take care not to damage them.

### Regular Cab

SEC. 678•749•769•803•805•809

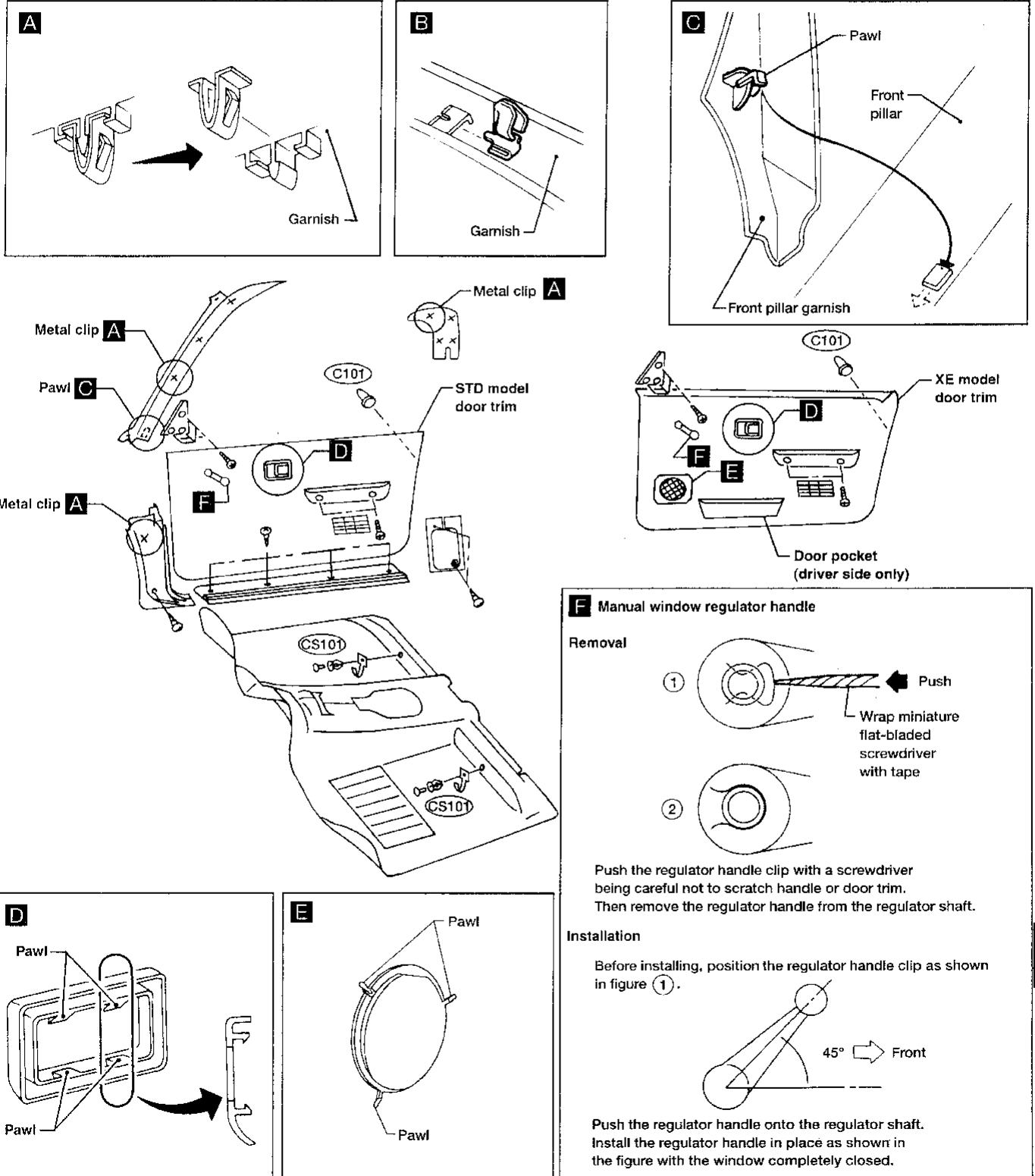

GI  
MA  
EM  
LC  
EC  
FE  
CL  
MT  
AT  
TF  
PD  
FA  
RA  
BR  
ST  
RS  
BT  
HA  
EL  
IDX

# INTERIOR TRIM

## Side and Floor Trim — Passenger room (Cont'd)

King Cab

SEC. 678•749•769•799•803•805•809

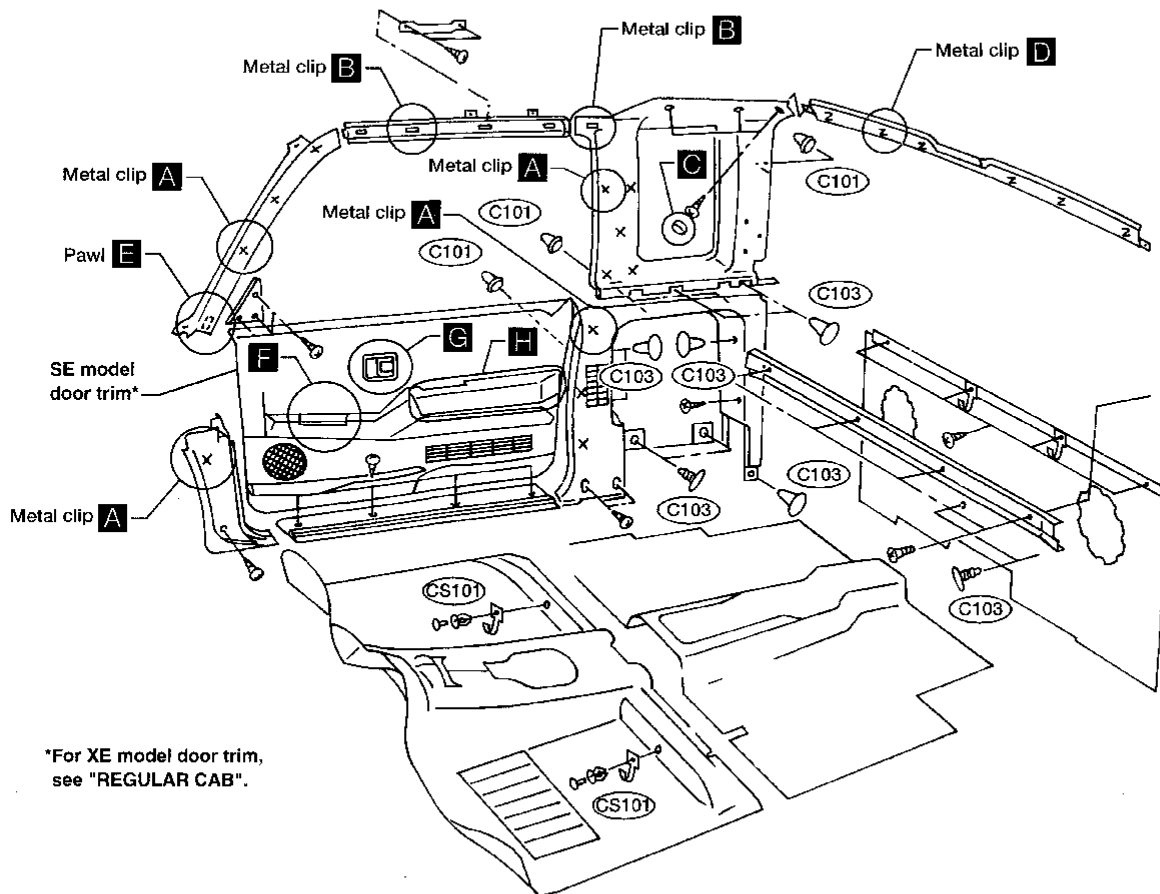
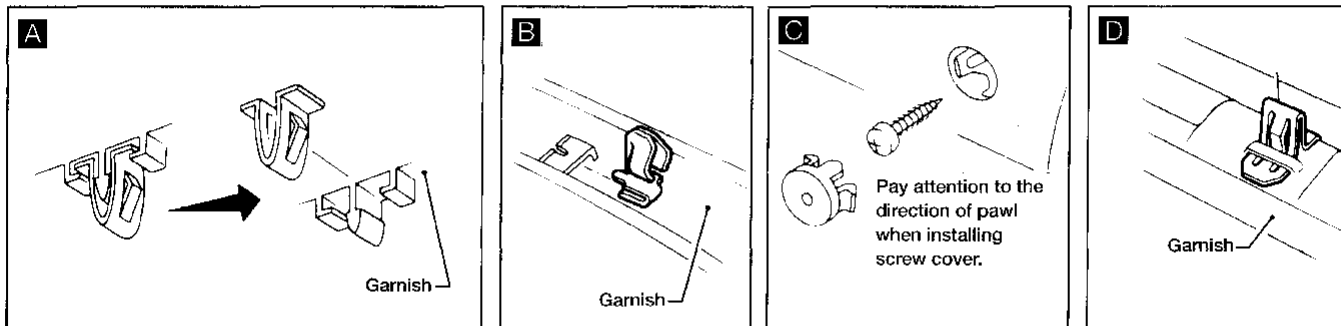

\*For XE model door trim,  
see "REGULAR CAB".

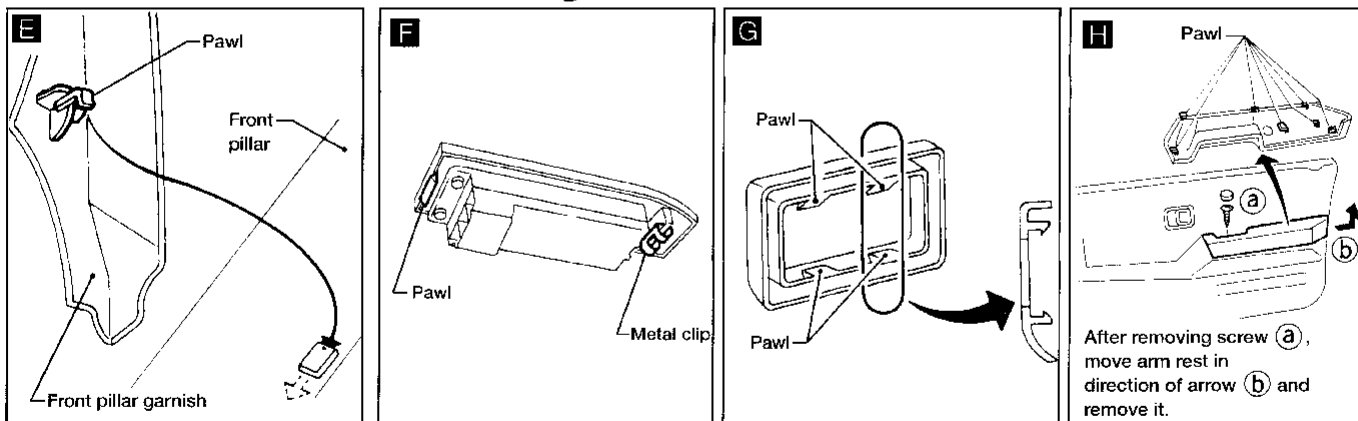

After removing screw (a),  
move arm rest in  
direction of arrow (b)  
and remove it.

ABT160

# INTERIOR TRIM

## Roof Trim

Regular Cab

SEC. 738•769•797•964

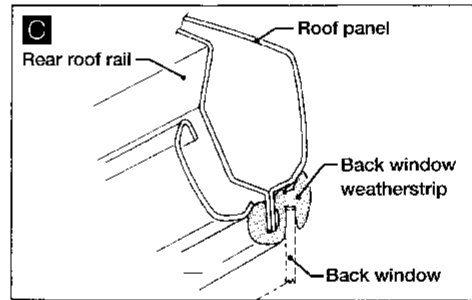
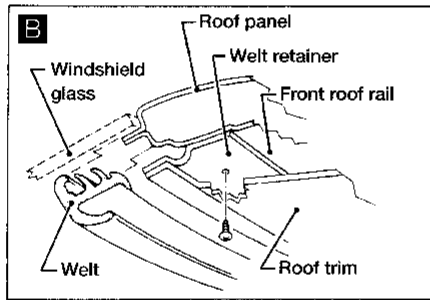
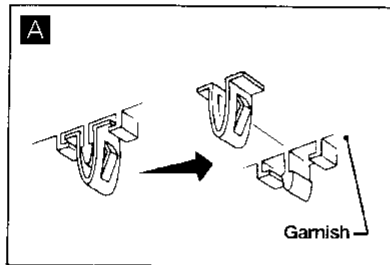
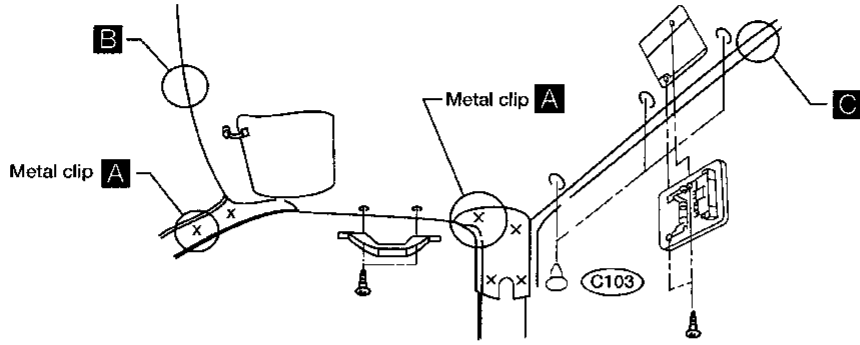

ABT162

GI  
MA  
EM  
LC  
EC  
FE  
CL  
MT  
AT  
TF  
PD  
FA  
RA  
BR  
ST  
RS  
BT  
HA  
EL  
IDX

# INTERIOR TRIM

## Roof Trim (Cont'd)

King Cab

SEC. 738•769•797•964

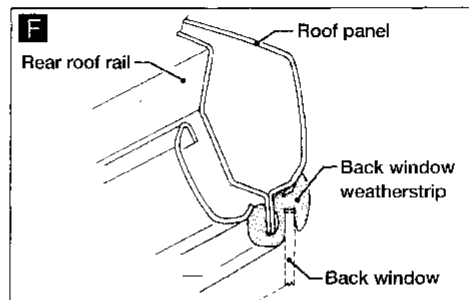
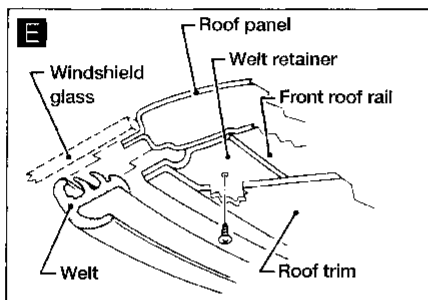
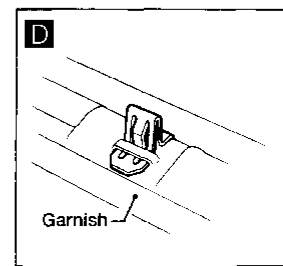
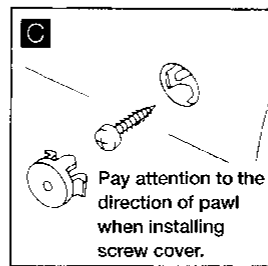
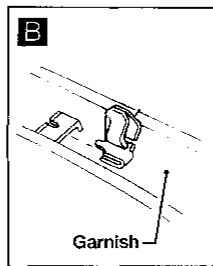
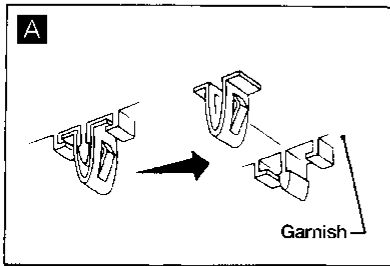
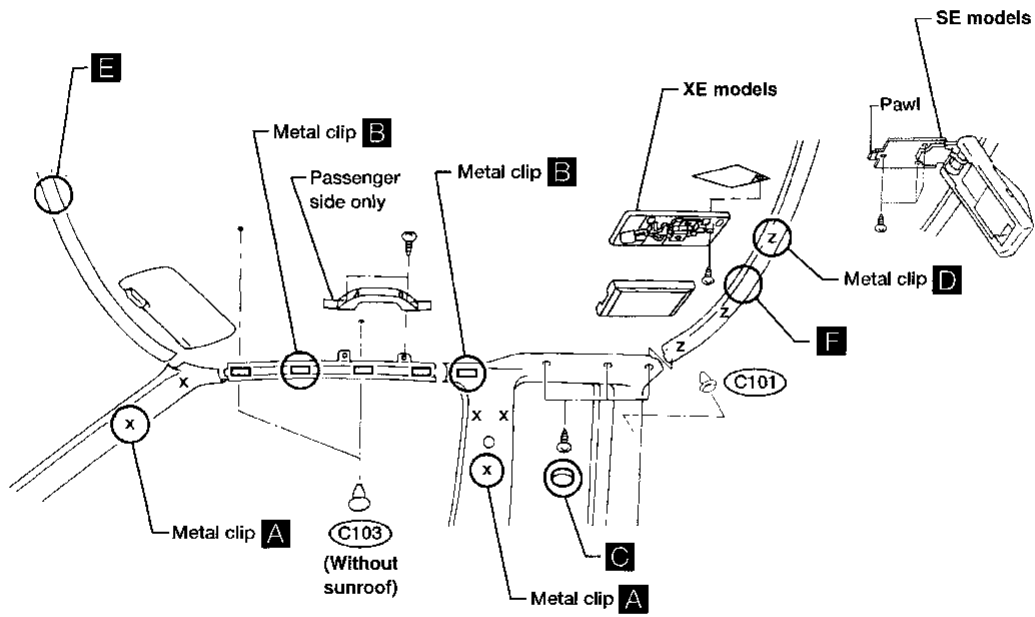

ABT158

# EXTERIOR

- Apply sealing compound where necessary while installing parts.
- When applying sealing compound, be careful that the sealing compound does not protrude from parts.

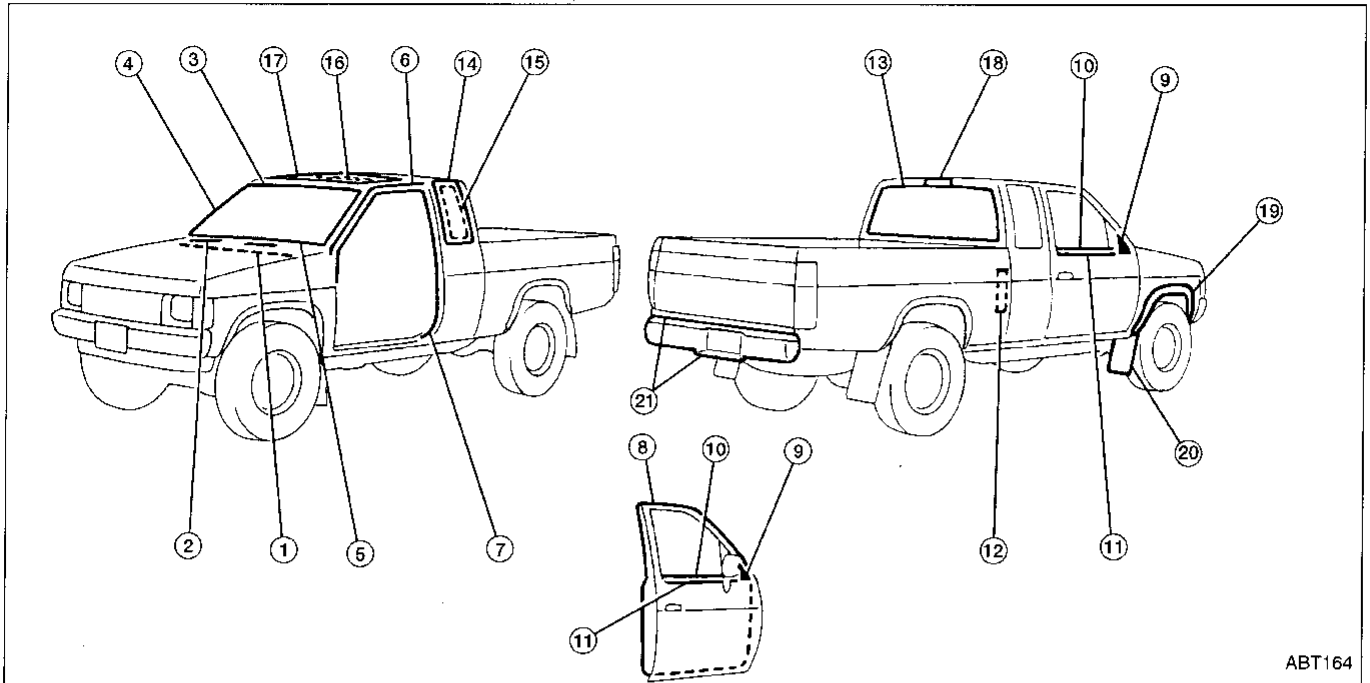

GI

MA

EM

LC

EC

FE

CL

WT

AT

TF

PD

FA

RA

BR

ST

RS

**BT**

HA

EL

IDX

## ① ② Cowl top sealing rubber & grille

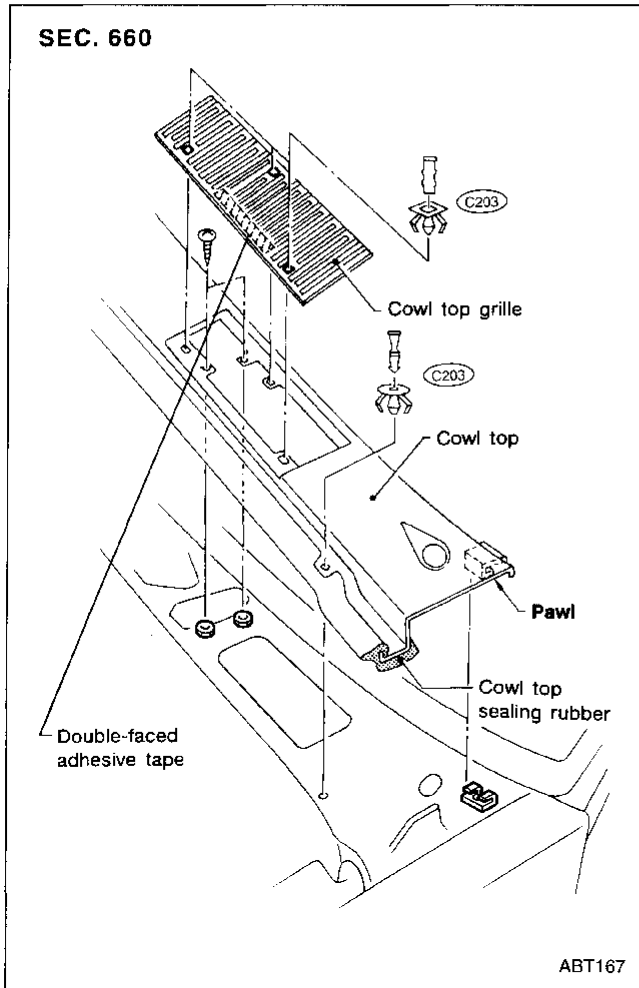

## ③ Windshield upper molding

### SEC. 720

#### Method 1

Cut off top portion of molding and clean glass and panel surfaces.

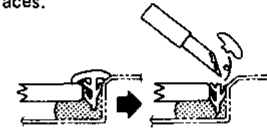

Apply sealant to top portion of molding.



Cut off lower portion of new molding



Finish well to give it a good appearance.

#### Method 2

1. Cut off sealant at glass end.
2. Clean the side on which panel was mounted.
3. Set molding fastener and apply sealant & primer to body panel, and apply primer to molding.

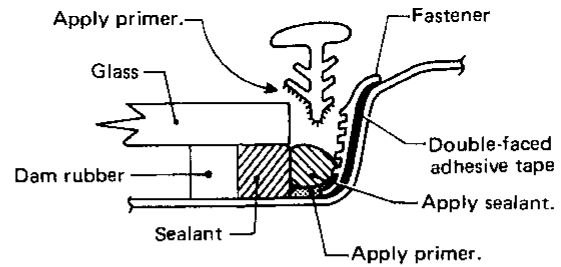

4. Install molding by aligning the molding mark located on center with vehicle center. Be sure to install tightly so that there is no gap around the corner.

ABT168

④ ⑤ Windshield side & lower molding

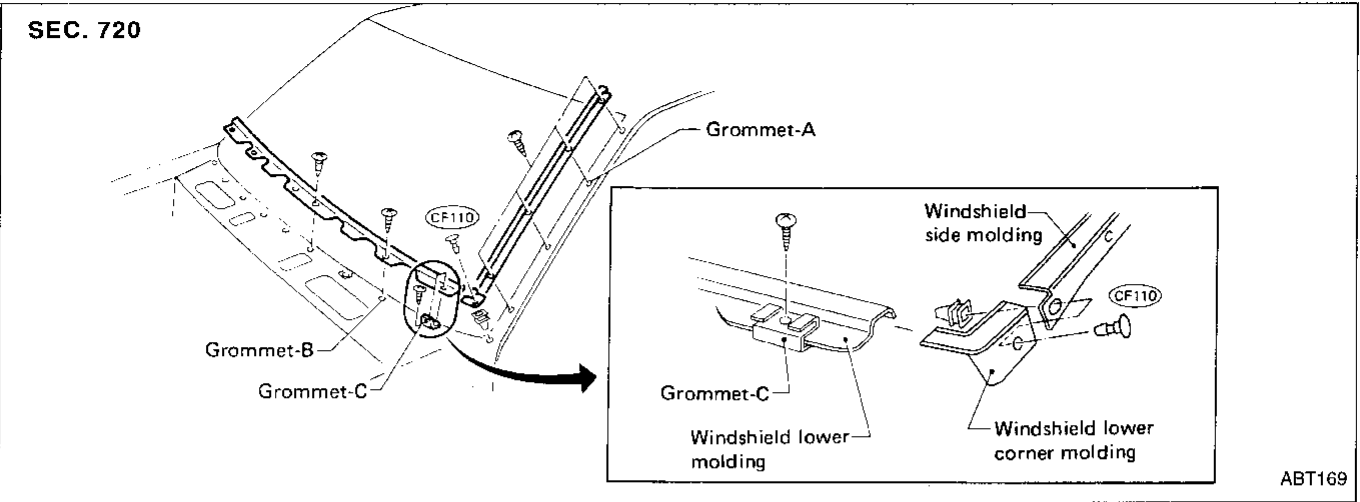

⑥ Drip weatherstrip

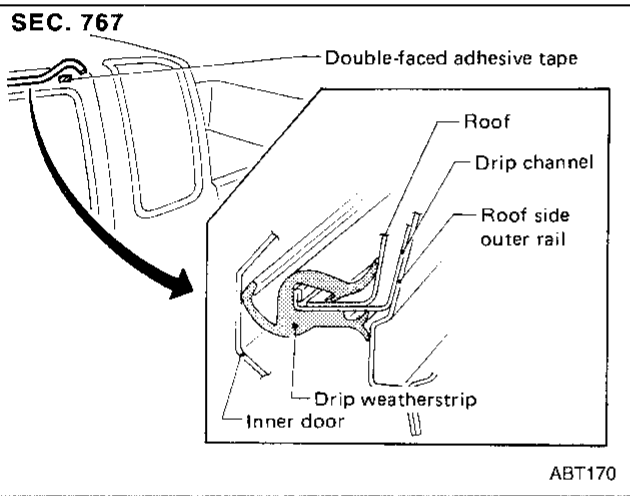

⑧ Door weatherstrip

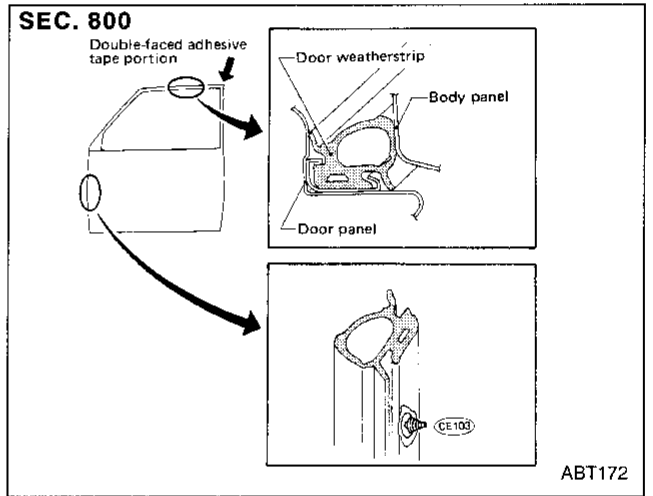

⑦ Body side welt

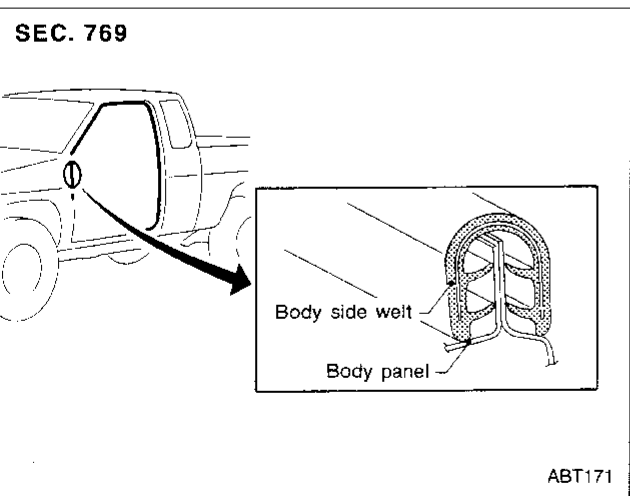

⑨ Door corner cover

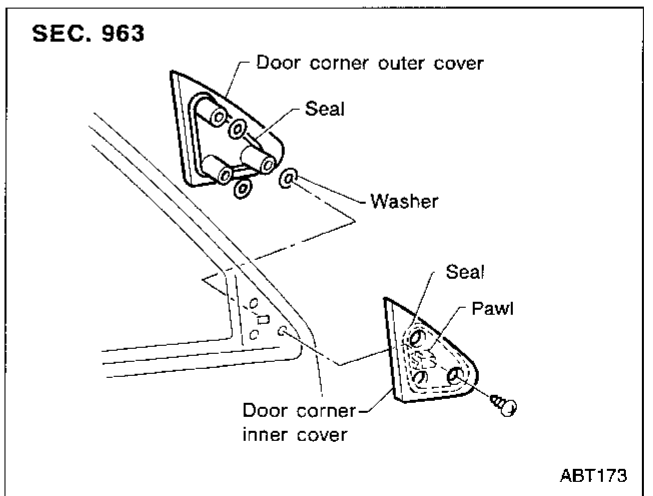

GI  
MA  
EM  
LC  
EC  
FE  
CL  
MT  
AT  
TF  
PD  
FA  
RA  
BR  
ST  
RS  
BT  
HA  
EL  
IDX

⑩ Door waist inner seal

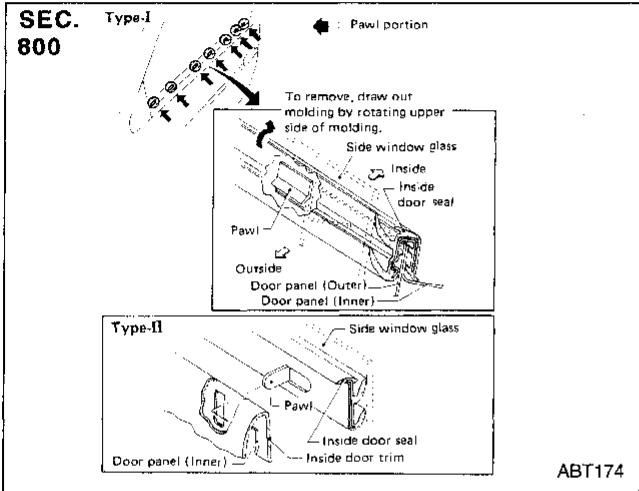

⑪ Door waist outer seal

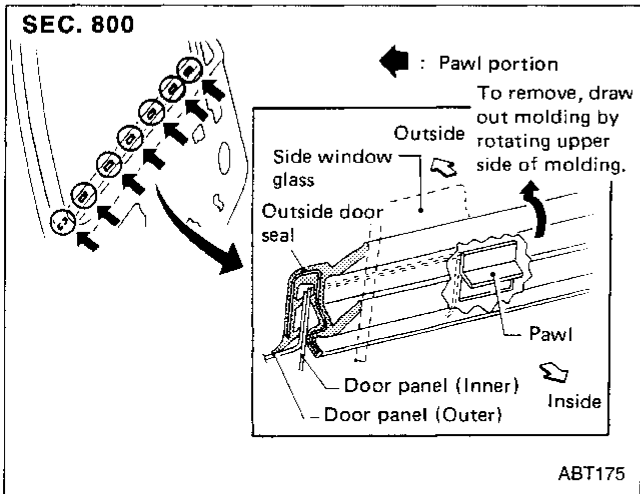

⑫ Drafter duct

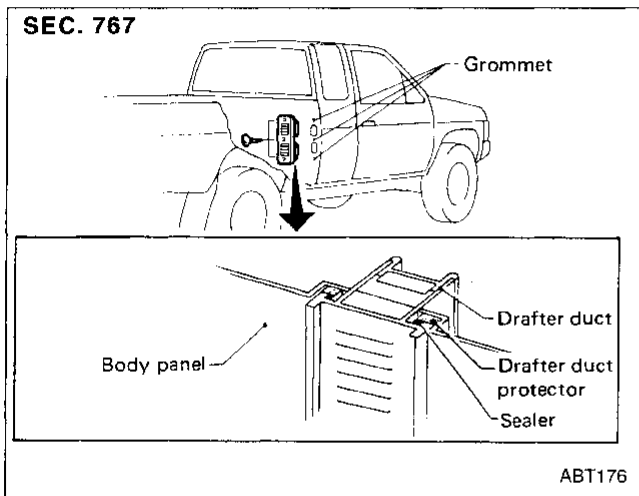

⑬ Back window

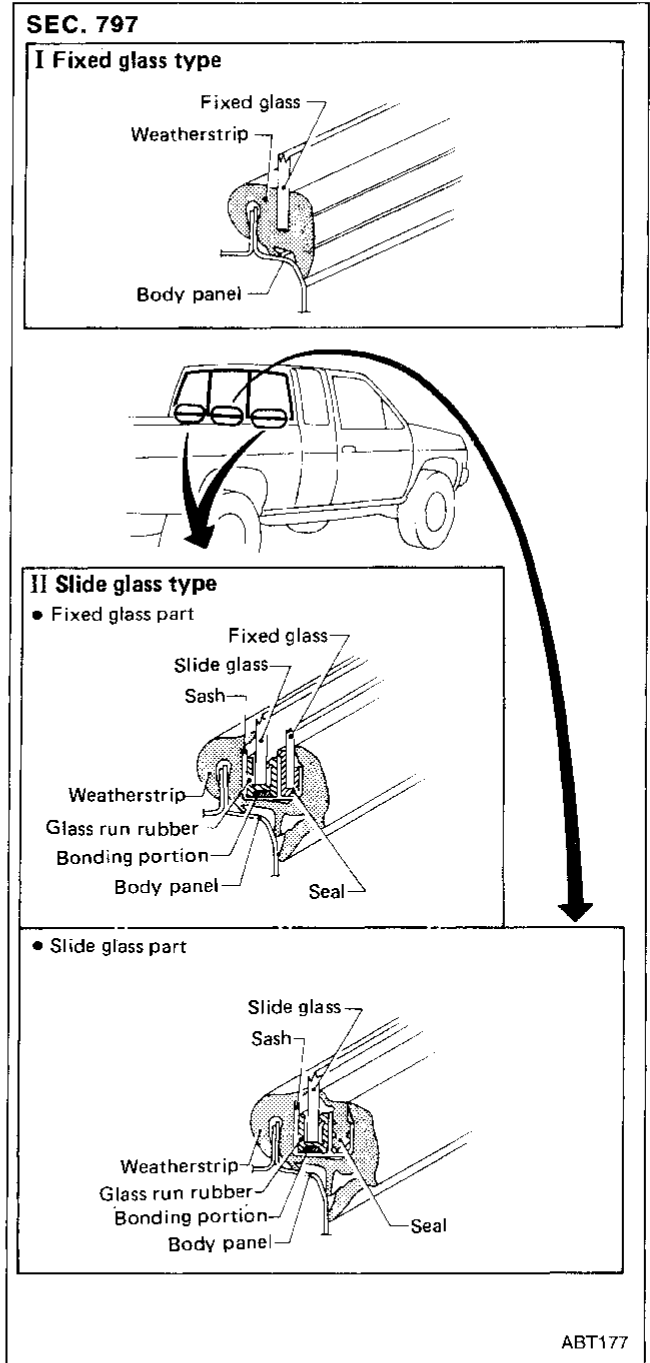

# EXTERIOR

## ⑭ ⑮ Rear side window weatherstrip and rear side window protector

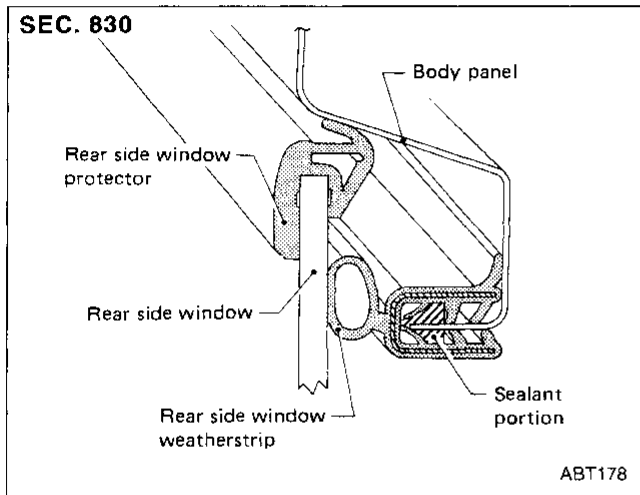

## ⑯ ⑰ Sunroof weatherstrip and lid protector

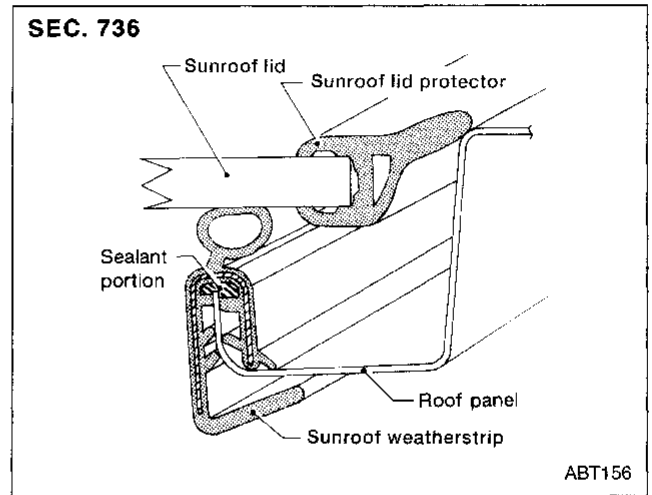

## ⑱ High-mounted stop lamp

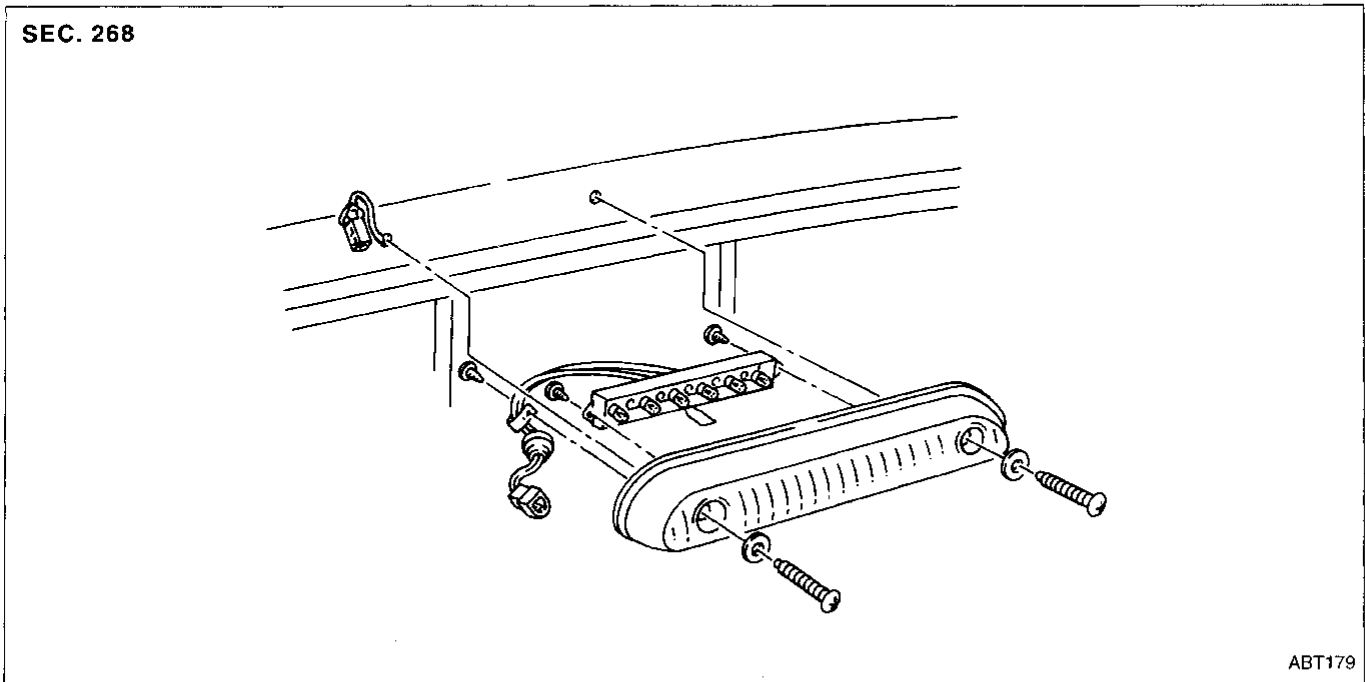

GI

MA

EM

LC

EC

FE

CL

MT

AT

TF

PD

FA

RA

BR

ST

RS

**BT**

HA

EL

LDX

19 20 Fender protector and mudguard

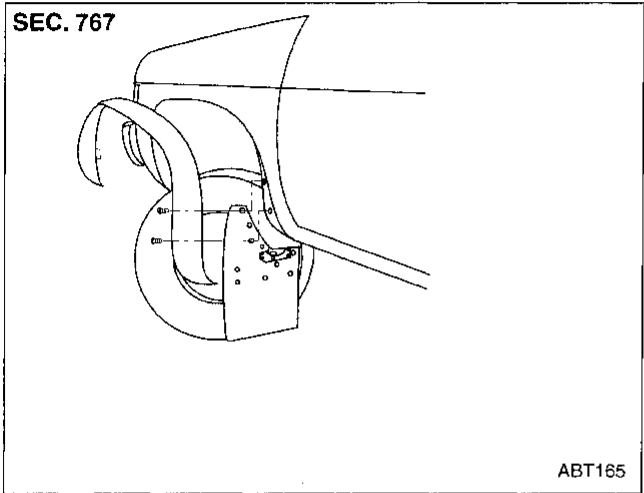

21 Step bumper cover

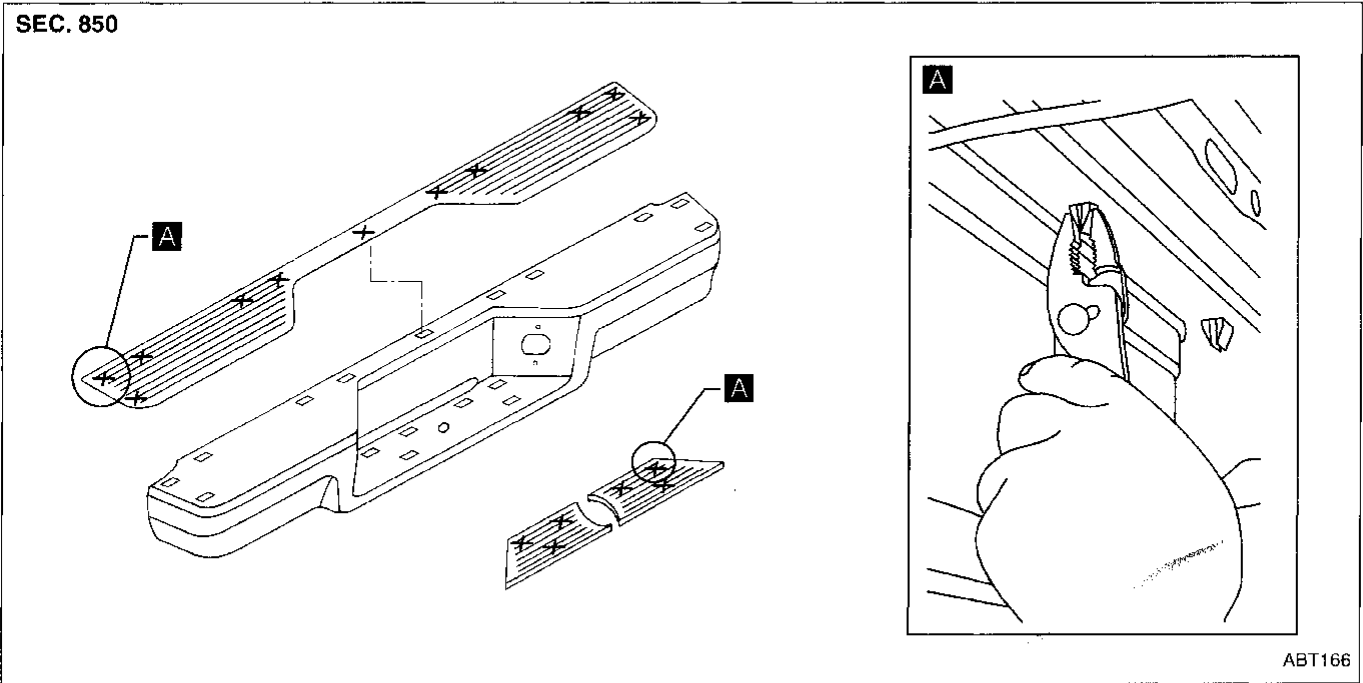

# SEAT

- When removing or installing the seat trim, carefully handle it to keep dirt out and avoid damage.

## Front Seat

### BUCKET SEAT

SEC. 870

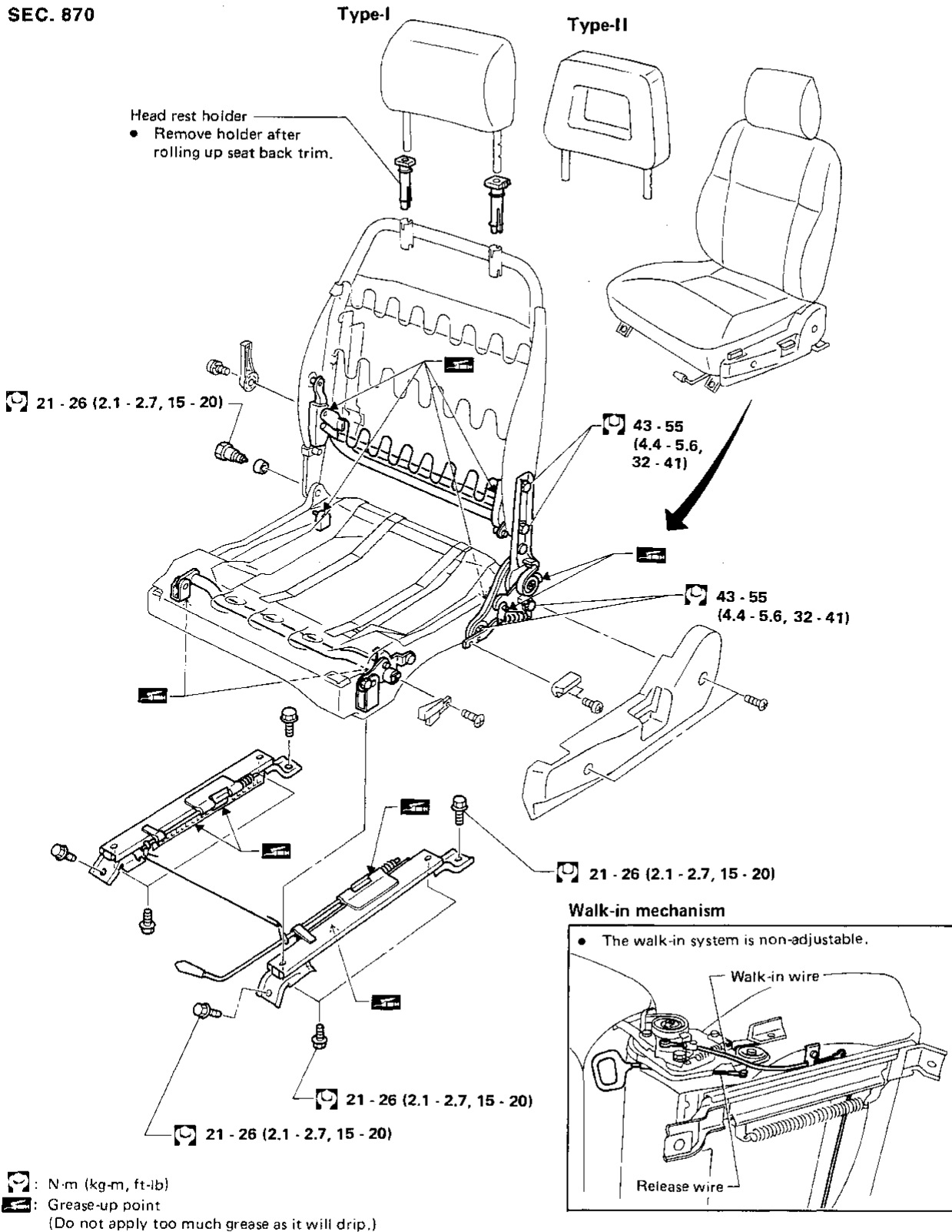

GI

MA

EM

LC

EC

FE

CL

MT

AT

TF

PD

FA

RA

BR

ST

RS

**BT**

HA

EL

IDX

# SEAT

## Front Seat (Cont'd)

### BENCH SEAT

#### SEC. 870

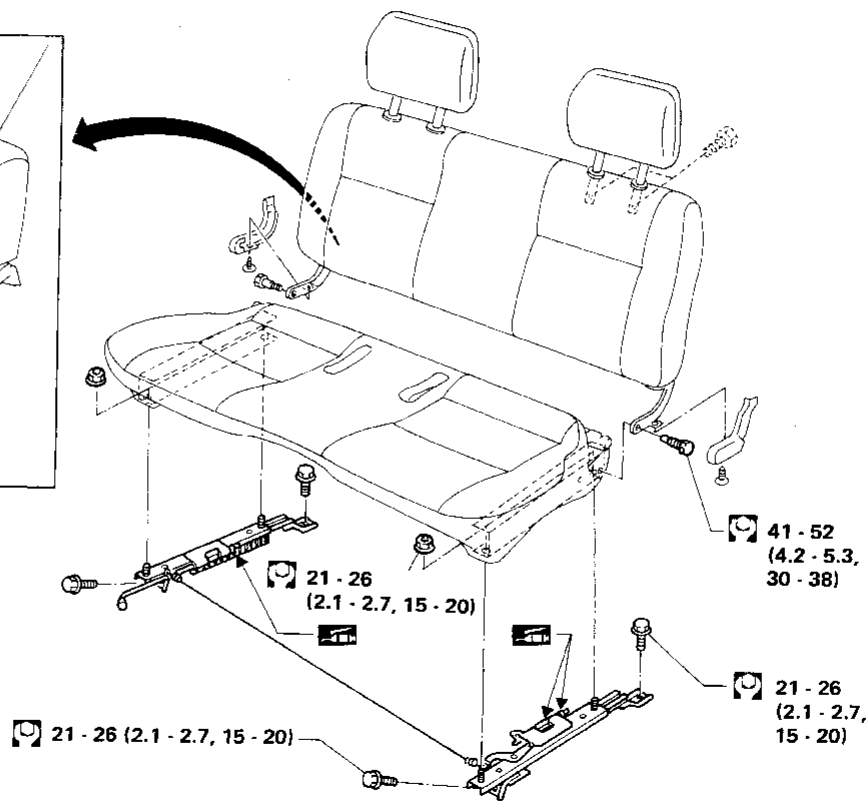
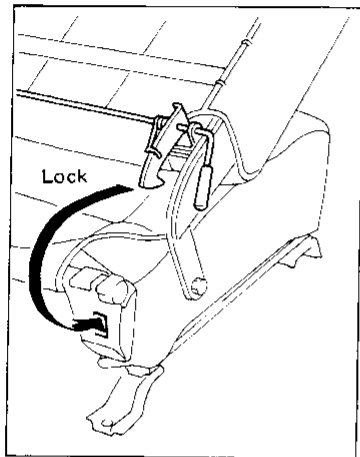

: N·m (kg·m, ft·lb)  
 : Grease-up points (Do not apply too much as it will drip.)

ABT181

### Jump Seat — King Cab Model

#### SEC. 880

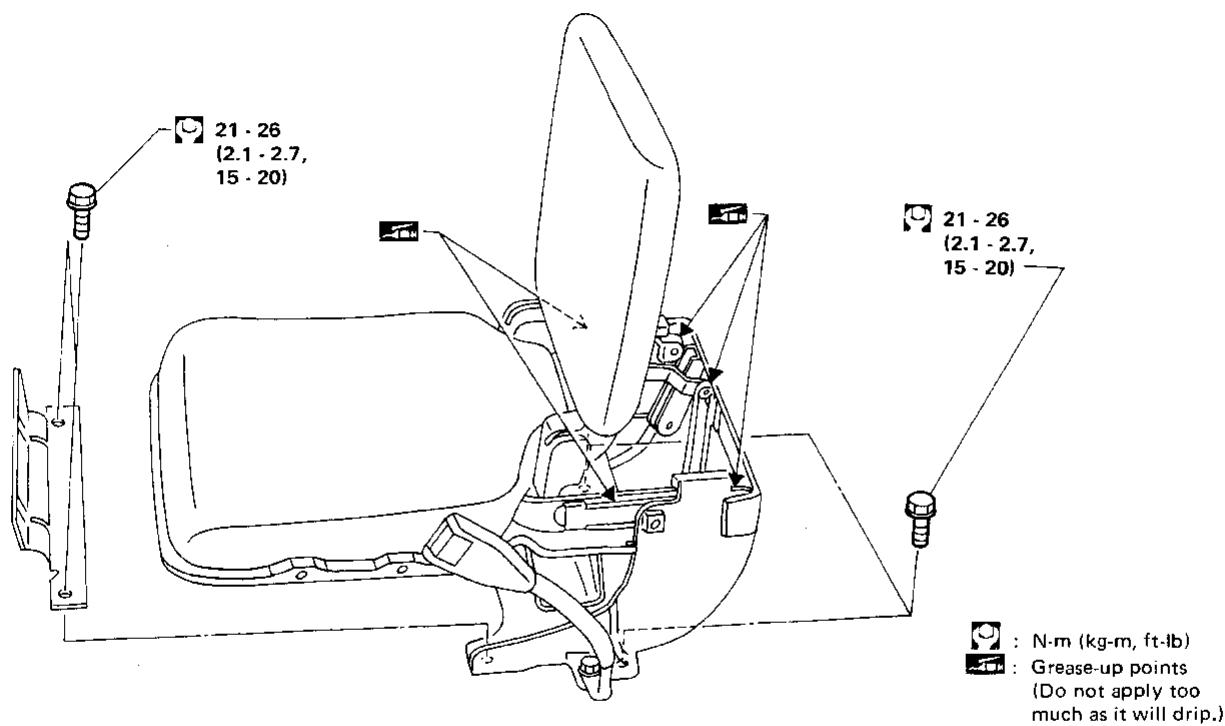

ABT182

# SUNROOF

## Service Procedure

GI  
MA  
EM  
LC  
EC  
FE  
CL  
MT  
AT  
TF  
PD  
FA  
RA  
BR  
ST  
RS  
BT  
HA  
EL  
LDX

SEC. 736

Handle

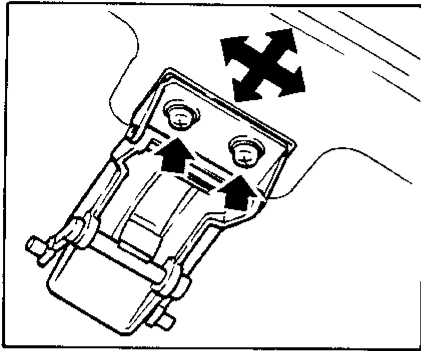

Female hinge

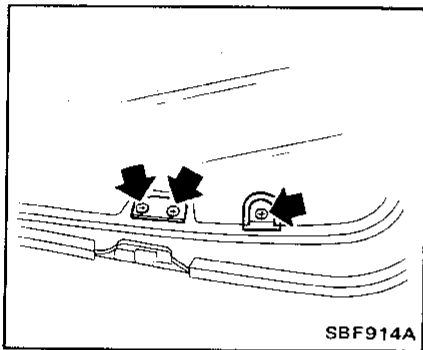

Hinge bracket

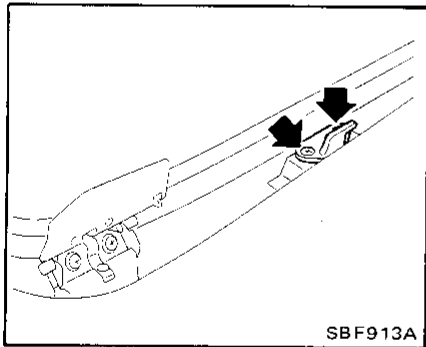

Air deflector

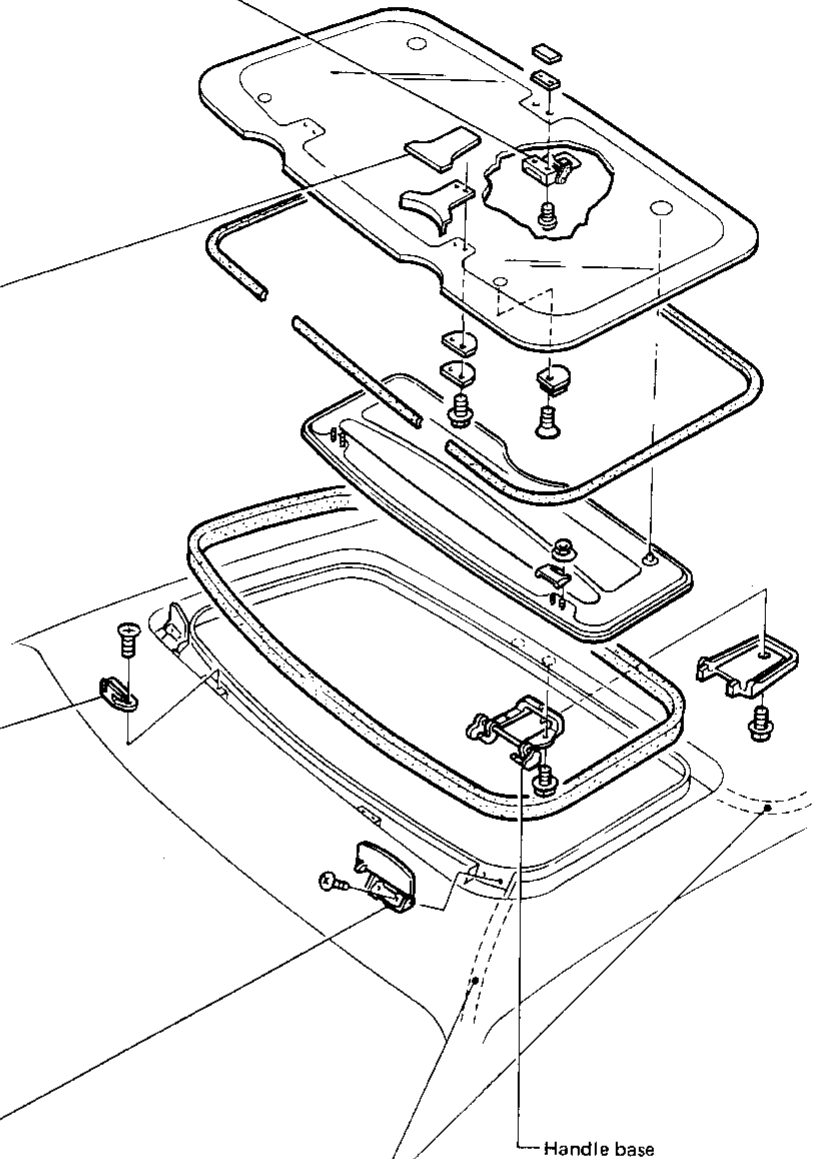
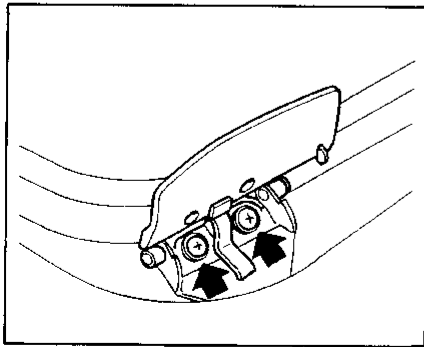

Drain hose  
After installation of drain hoses, make sure water drains smoothly.

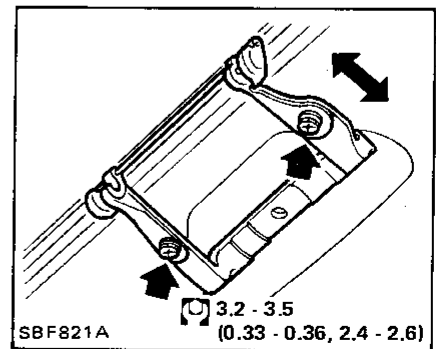

: N·m (kg-m, ft-lb)

ABT183

# WINDSHIELD AND WINDOWS

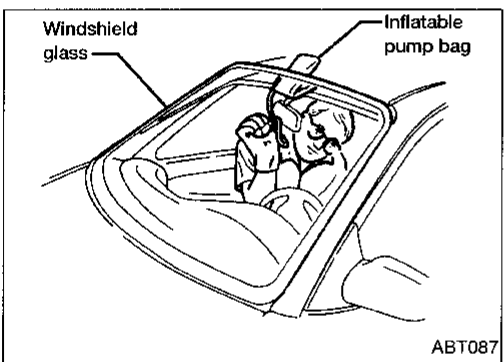
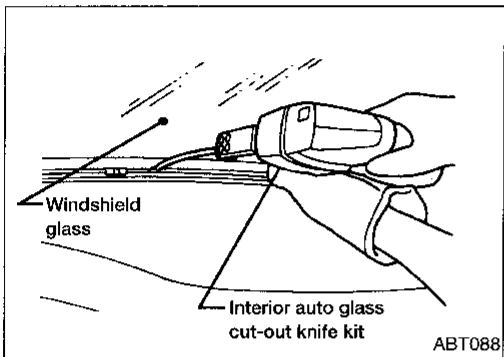
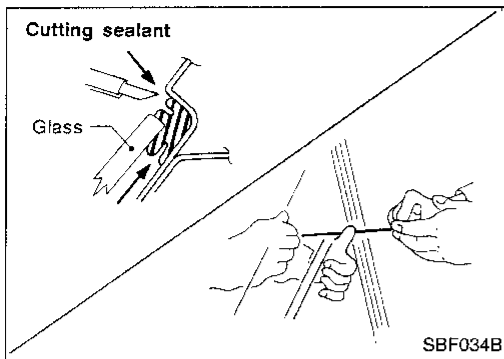

## REMOVAL

After removing moldings, remove glass using piano wire or power cutting tool and an inflatable pump bag.

### CAUTION:

Be careful not to scratch glass when removing.

## INSTALLATION

- Use genuine Nissan Sealant kit or equivalent. Follow instructions furnished with it.
- After installation, the vehicle should remain stationary until the sealant hardens.

### WARNING:

Keep heat and open flames away as primers are flammable.

### CAUTION:

Advise the user not to drive the vehicle on rough roads or surfaces for 24 hours after installation.

- Do not use sealant which is past its usable term.
- Do not leave cartridge unattended with its cap open.
- Keep primers and sealant in a cool, dry place. Ideally, they should be stored in a refrigerator.
- Molding must be installed securely so that it is in position and leaves no gap.

## Windshield

### Body side

**SEC. 720**

Install molding fastener.  
When installing it, heat body panel and fastener to approx. 30 to 40° C (86 to 104° F).

SBF500C

Install dam rubber & spacers with double-faced adhesive tape.

SBF389D

Install spacers to panel.

L.H. side only

Unit: mm (in)

SBF785D

ABT184

### Sealant application areas

Apply sealant to windshield

MBF786A

Apply sealant to back door window

MBF787A

Apply sealant evenly.

Unit: mm (in)

MBF788A

Apply sealant additionally to lower portion of glass and make it uniform as shown below.

SBF727C

MBF919A

# WINDSHIELD AND WINDOWS

## Windshield (Cont'd)

### REPAIRING WATER LEAKS FOR WINDSHIELD

Leaks can be repaired without removing and reinstalling glass.

**If water is leaking between caulking material and body or glass, determine the extent of the leak. This can be done by applying water while pushing glass outward.**

To stop the leak, apply primer (if necessary) and then sealant to the leak point.

### Back Window

- Window glass is held in place by weatherstripping. For details regarding weatherstrip, refer to "EXTERIOR", BT-17.
- Using sealant, fill gaps between vehicle body and weatherstrip as necessary.

SEC. 797

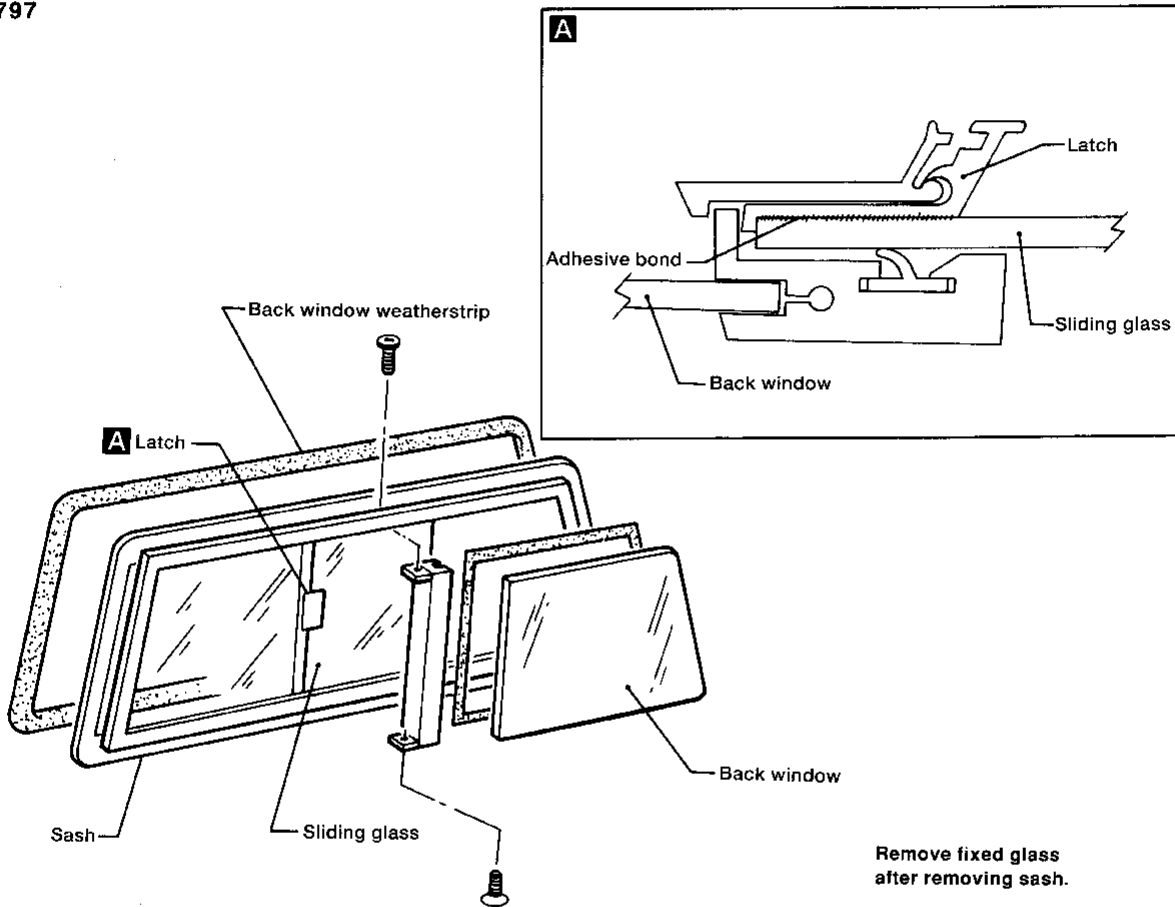

ABT185

Rear Side Window

GI  
MA  
EM  
LC  
EC  
FE  
CL  
MT  
AT  
TF  
PD  
FA  
RA  
BR  
ST  
RS  
BT  
HA  
EL  
IDX

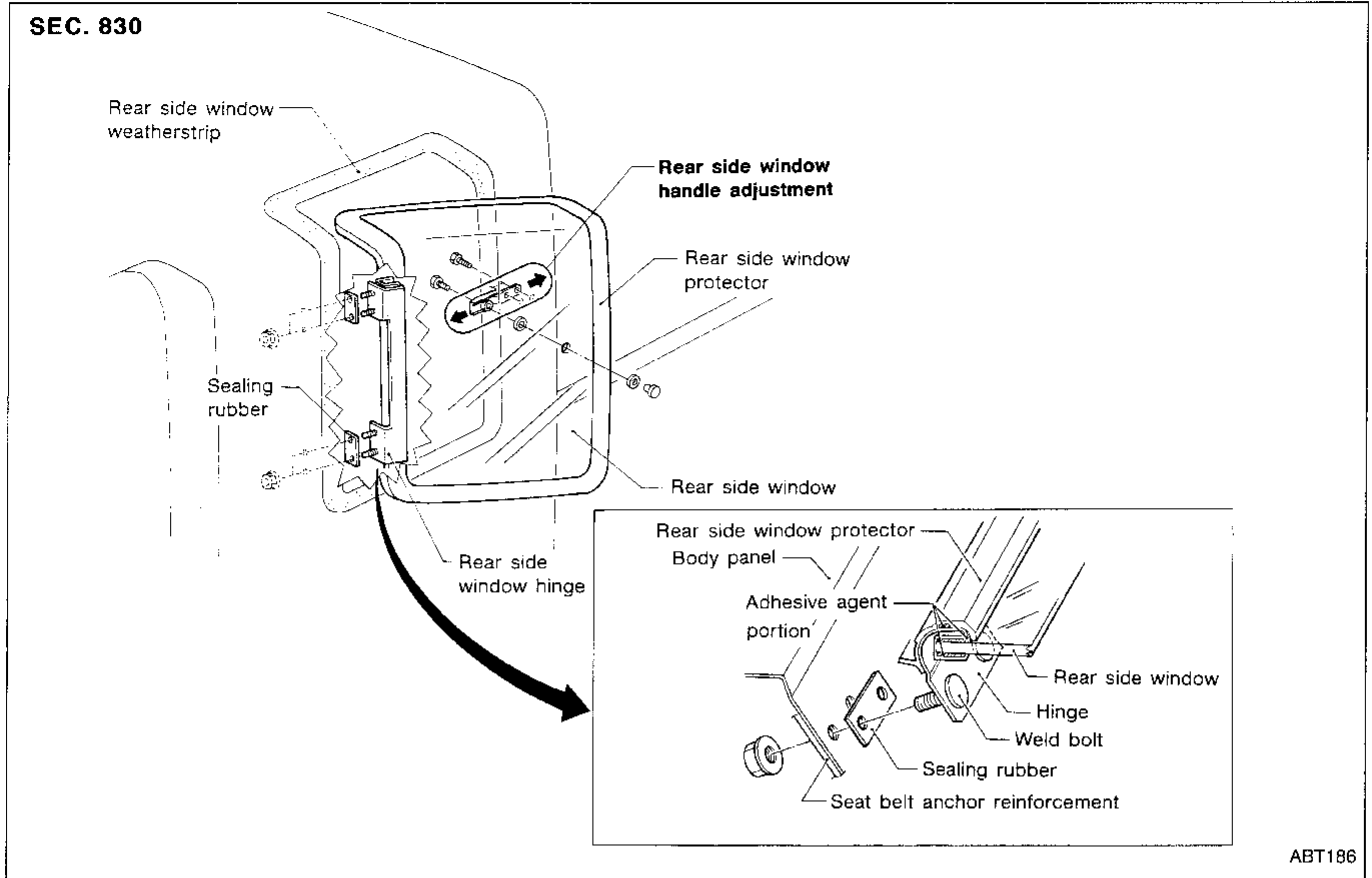

ABT186

# MIRROR

## Door Mirror

SEC. 963

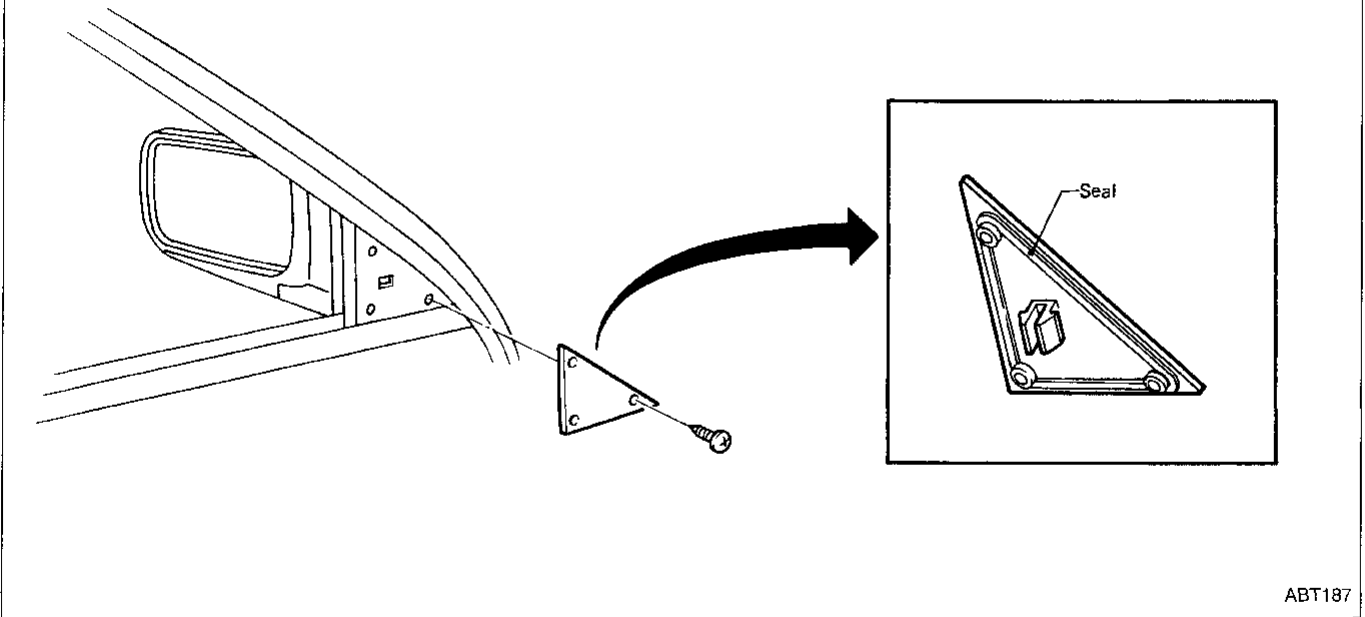

ABT187

★ For Wiring Diagram, refer to "MIRROR" in EL section.

# MIRROR

## Rearview Mirror

### REMOVAL

Remove rearview mirror by deflecting spring with screwdriver as shown in the figure.

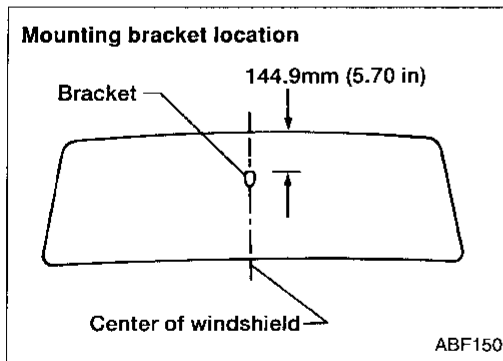
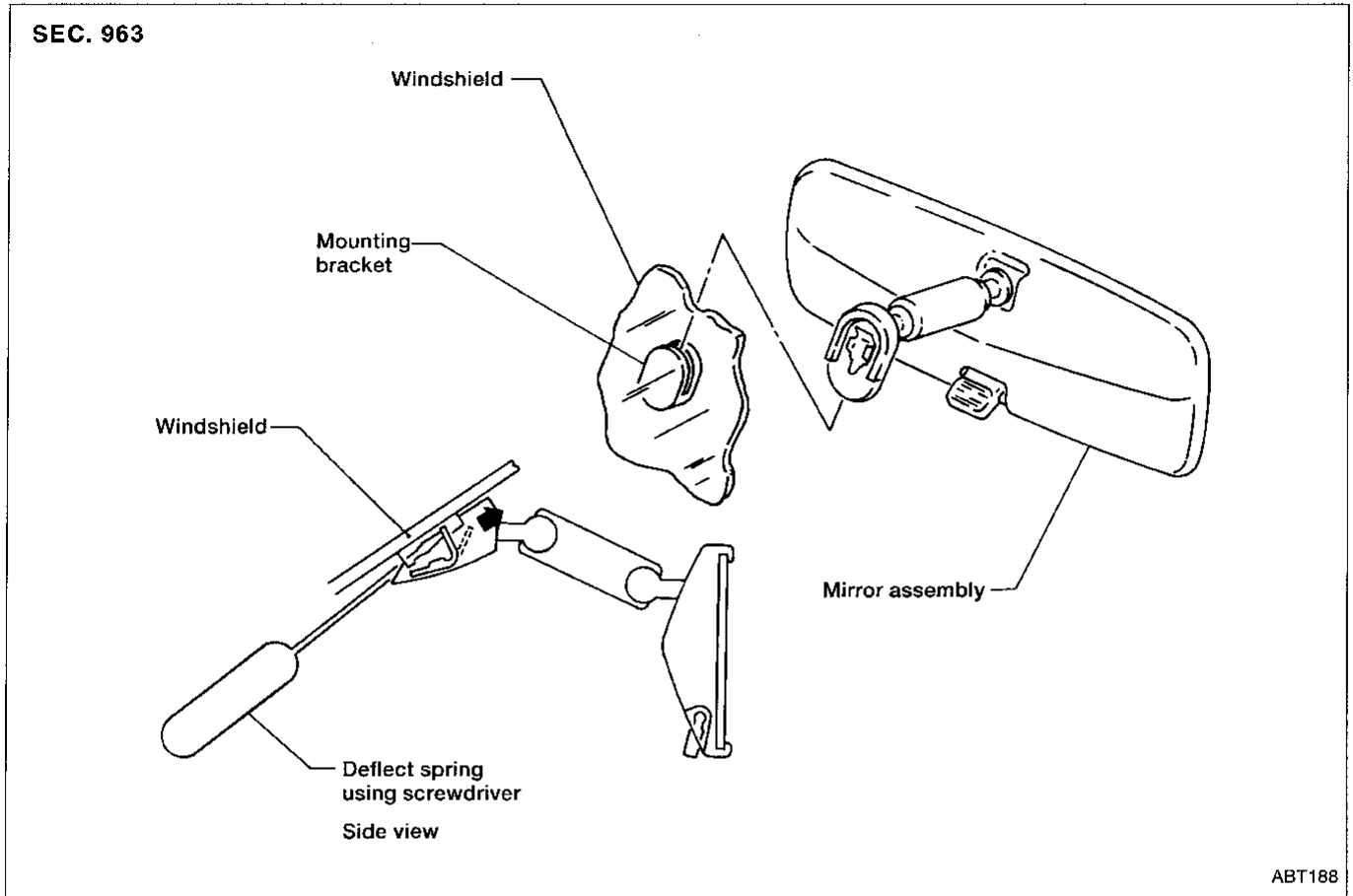

### INSTALLATION

1. Install mounting bracket as follows:
  - a. Determine mounting bracket position on windshield by measuring from top of windshield to top of mounting bracket as shown in the figure.
  - b. Mark location on outside of windshield with wax pencil or equivalent.
  - c. Clean attaching point on inside of windshield with an alcohol-saturated paper towel.
  - d. Sand bonding surface of mounting bracket with sandpaper (No. 320 or No. 360).
  - e. Clean bonding surface of mounting bracket with an alcohol-saturated paper towel.
  - f. Apply Loctite Adhesive 11067-2 or equivalent to bonding surface of mounting bracket.
  - g. Install mounting bracket at premarked position and press mounting bracket against glass for 30 to 60 seconds.
  - h. After five minutes, wipe off excess adhesive with an alcohol-moistened paper towel.
2. Install rearview mirror.

## CAB AND REAR BODY

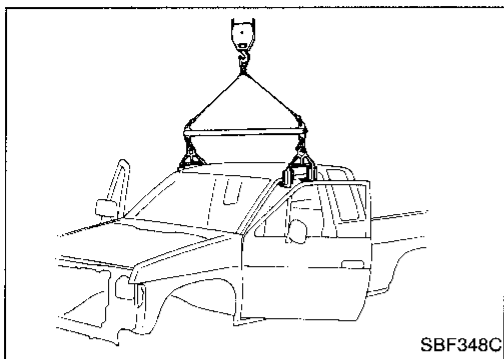

### Removal

#### CAB BODY

- Remove the following parts in engine compartment at least.
  - (1) Main harness and other wiring harnesses
- Disconnect brake and clutch lines in engine compartment.
- Remove the following parts from underbody at least.
  - (1) Transmission and transfer control levers
  - (2) Parking brake control lever and cables
  - (3) Main harness and other wiring harnesses

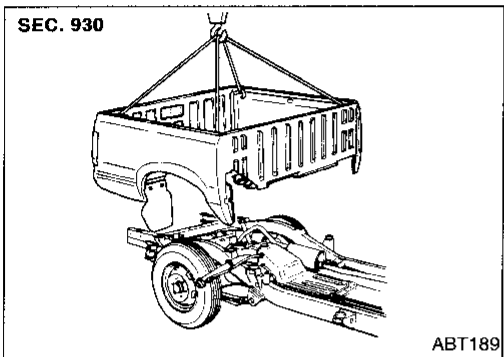

#### REAR BODY

- Remove the following parts at least.
  - (1) Rear combination lamp and license plate lamp harness
  - (2) Fuel filler tube fixing screws

# CAB AND REAR BODY

## Body Mounting

When installing, be sure to use new bolts and nuts (sealant applied bolts or self-lock nuts are used for all mounting).

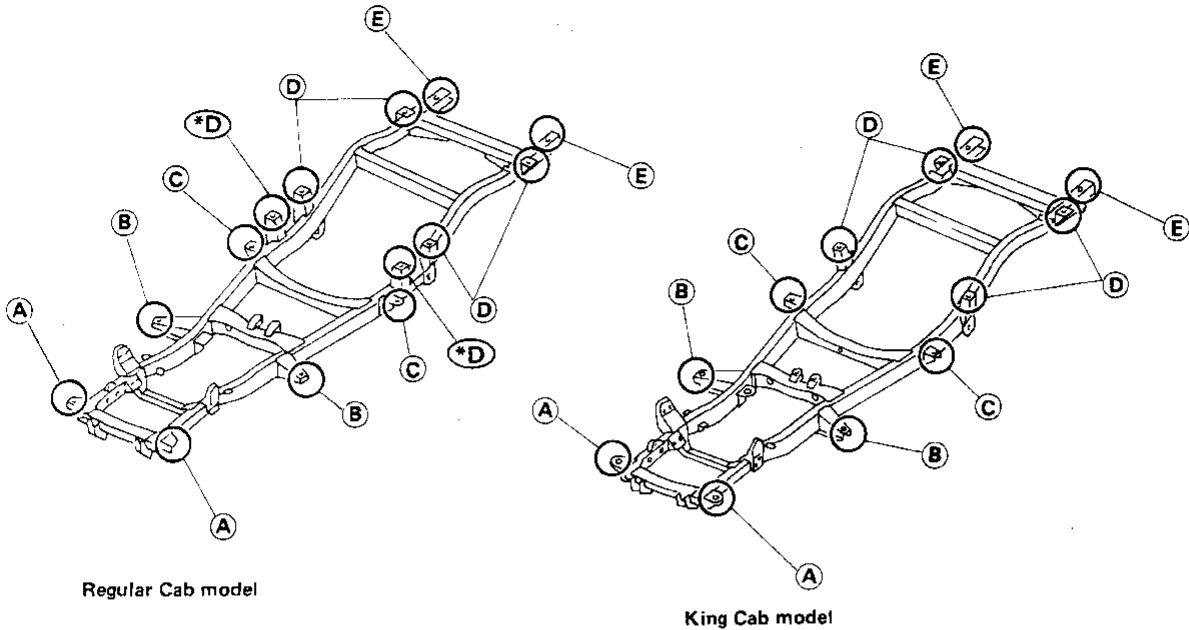

Regular Cab model

King Cab model

\*D : Except for short wheelbase model (This bracket is not used for body mounting.)

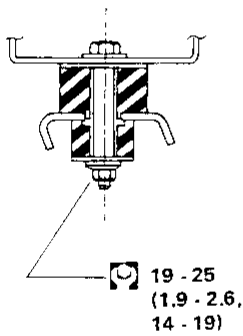

Section A

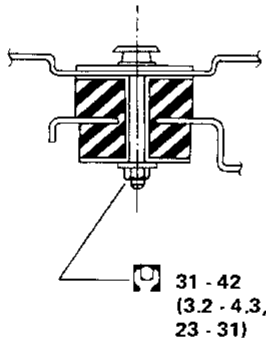

Section B

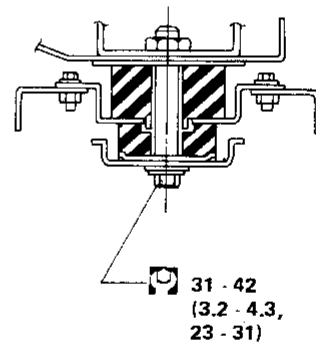

Section C

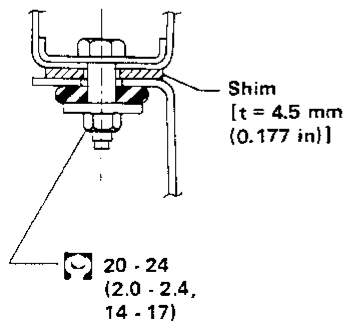

Section D

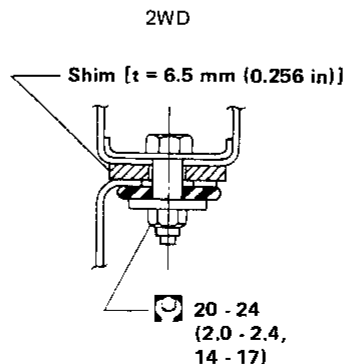

Section E

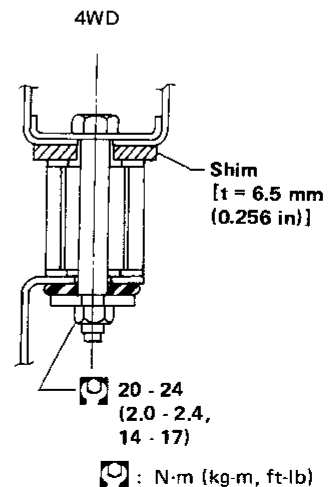

SBF350C

GI  
MA  
EM  
LC  
EC  
FE  
CL  
MT  
AT  
TF  
PD  
FA  
RA  
BR  
ST  
RS  
BT  
HA  
EL  
IDX

## BODY ALIGNMENT

- All dimensions indicated in figures are actual ones.
- When using a tracking gauge, adjust both pointers to equal length. Make sure there is no free play.
- When a measuring tape is used, check to be sure there is no elongation, twisting or bending.
- Measurements should be taken at the center of the mounting holes.
- All measurements and mounting hole diameters are expressed in millimeters (mm).
- An asterisk (\*) following the value at the measuring point indicates that the measuring point on the other side is symmetrically the same value.
- The coordinates of the measurement points are the distances measured from the respective dimension lines in the directions of "x", "y" and "z".

Dimension lines: "x" line — Center line of vehicle

"y" line — Center line of front axle (Any measurement point in front of the dimension line refers to a minus "-" value.)

"z" line — Datum line (Any measurement point under the dimension line refers to a minus "-" value.)

**2W** : 2WD

**2W.SB** : Short wheelbase (2WD)

**4W** : 4WD

**2W.LB** : Long wheelbase (2WD)

**SB** : Short wheelbase

**4W.SB** : Short wheelbase (4WD)

**LB** : Long wheelbase

**4W.LB** : Long wheelbase (4WD)

**R** : Regular Cab

**K** : King Cab

# BODY ALIGNMENT

## Engine Compartment

### MEASUREMENT

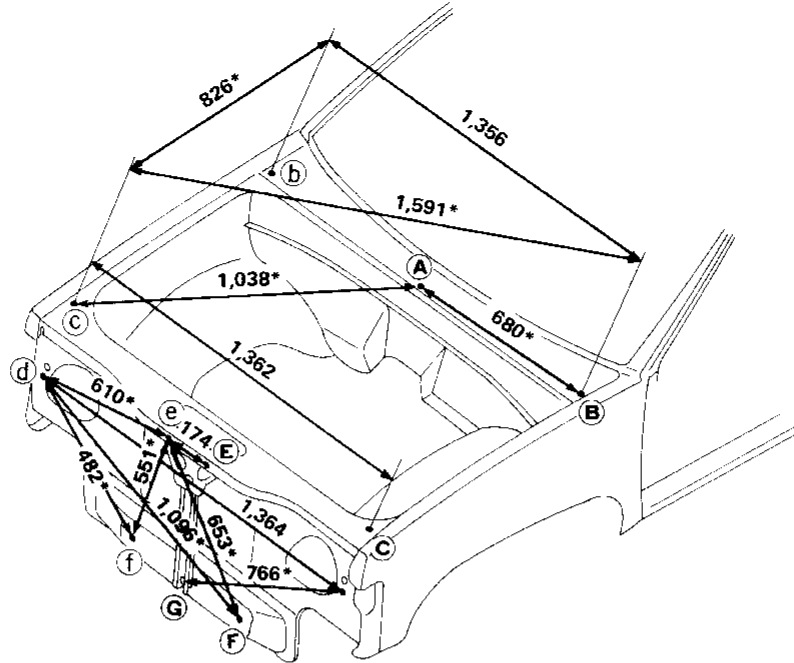

Unit: mm

### DETAILED MEASUREMENT POINTS

Unit: mm

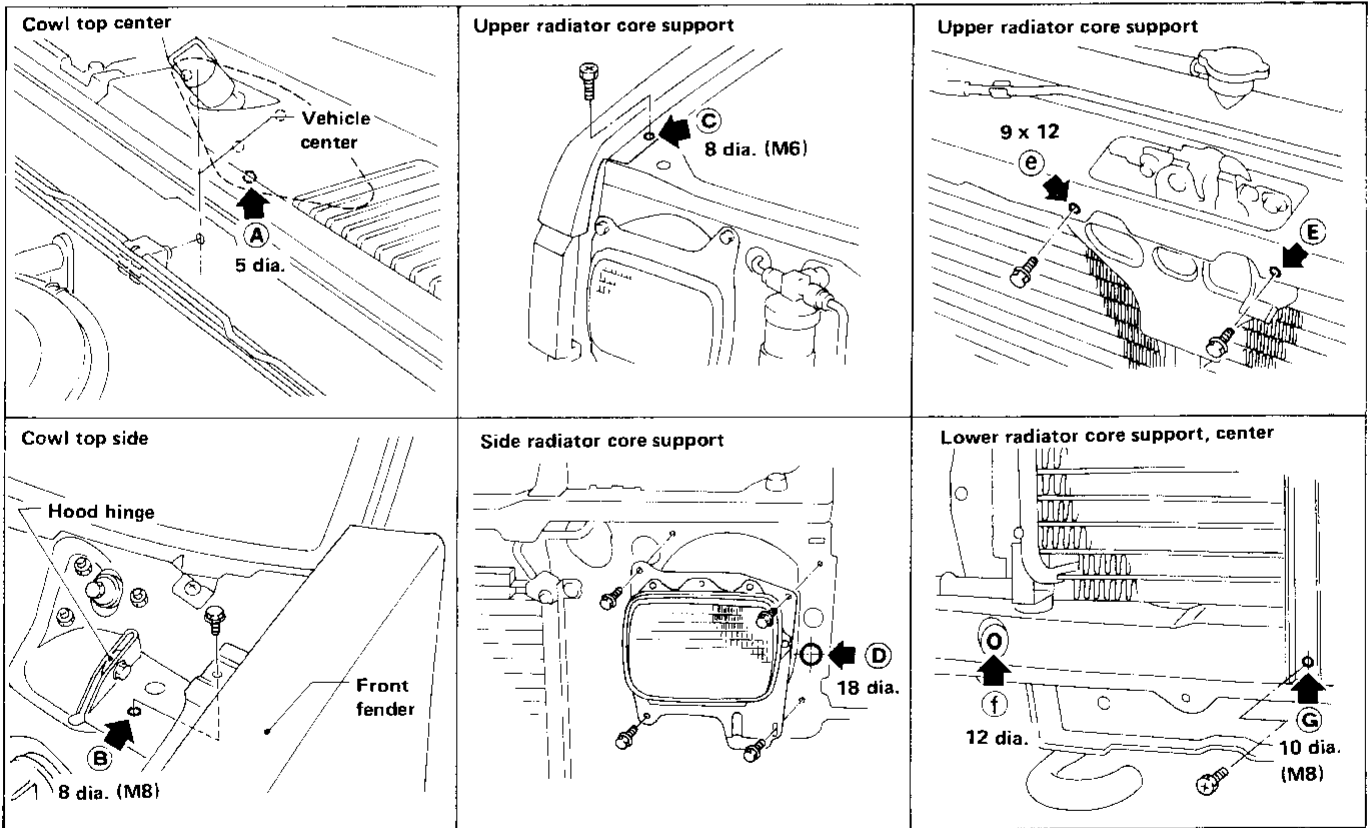

MBF726A

# BODY ALIGNMENT

## Underbody

### MEASUREMENT POINTS

2WD models

**R** : Regular cab  
**K** : King cab

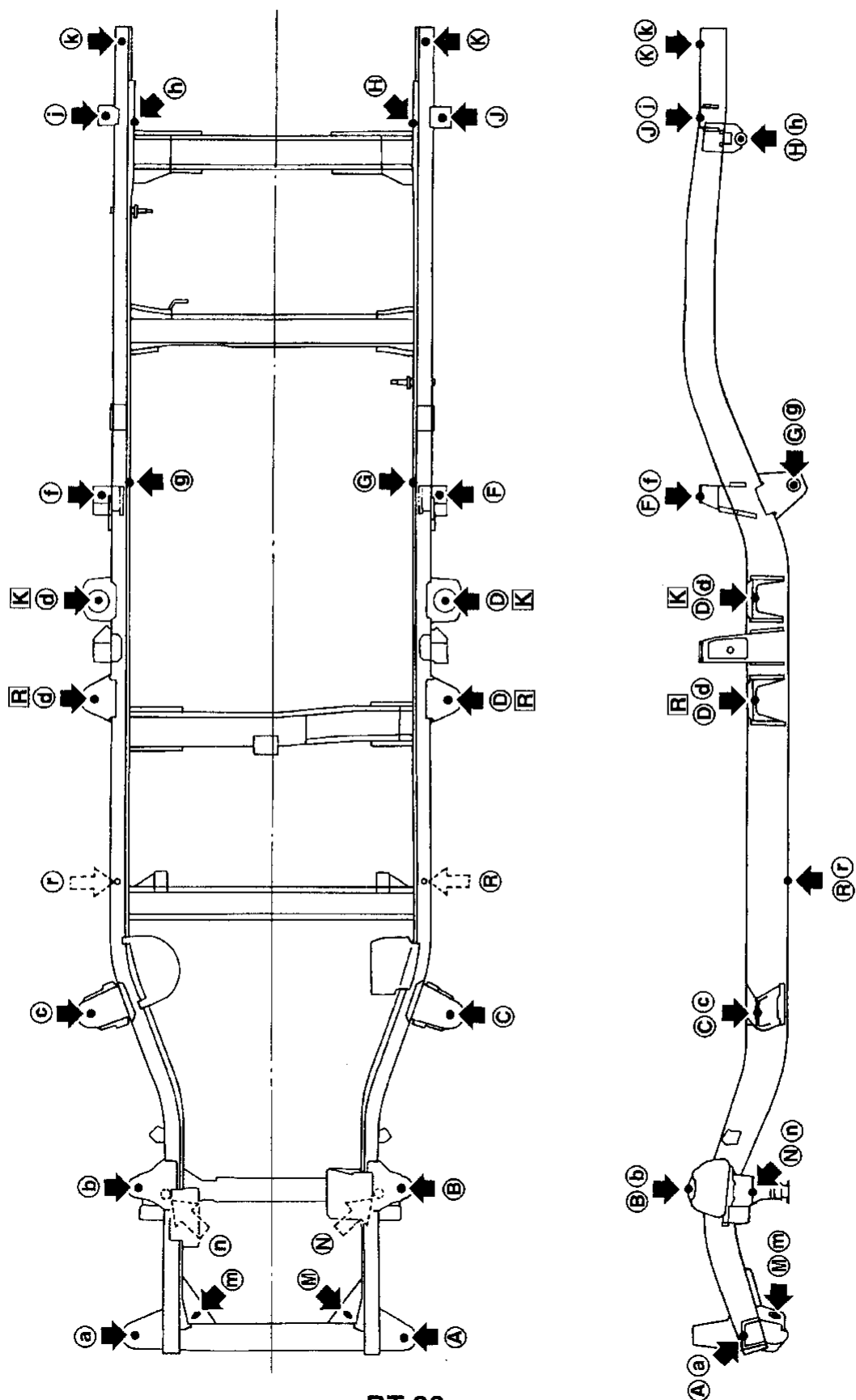

# BODY ALIGNMENT

## Underbody (Cont'd)

### MEASUREMENT POINTS

4WD models

**R** : Regular cab  
**K** : King cab

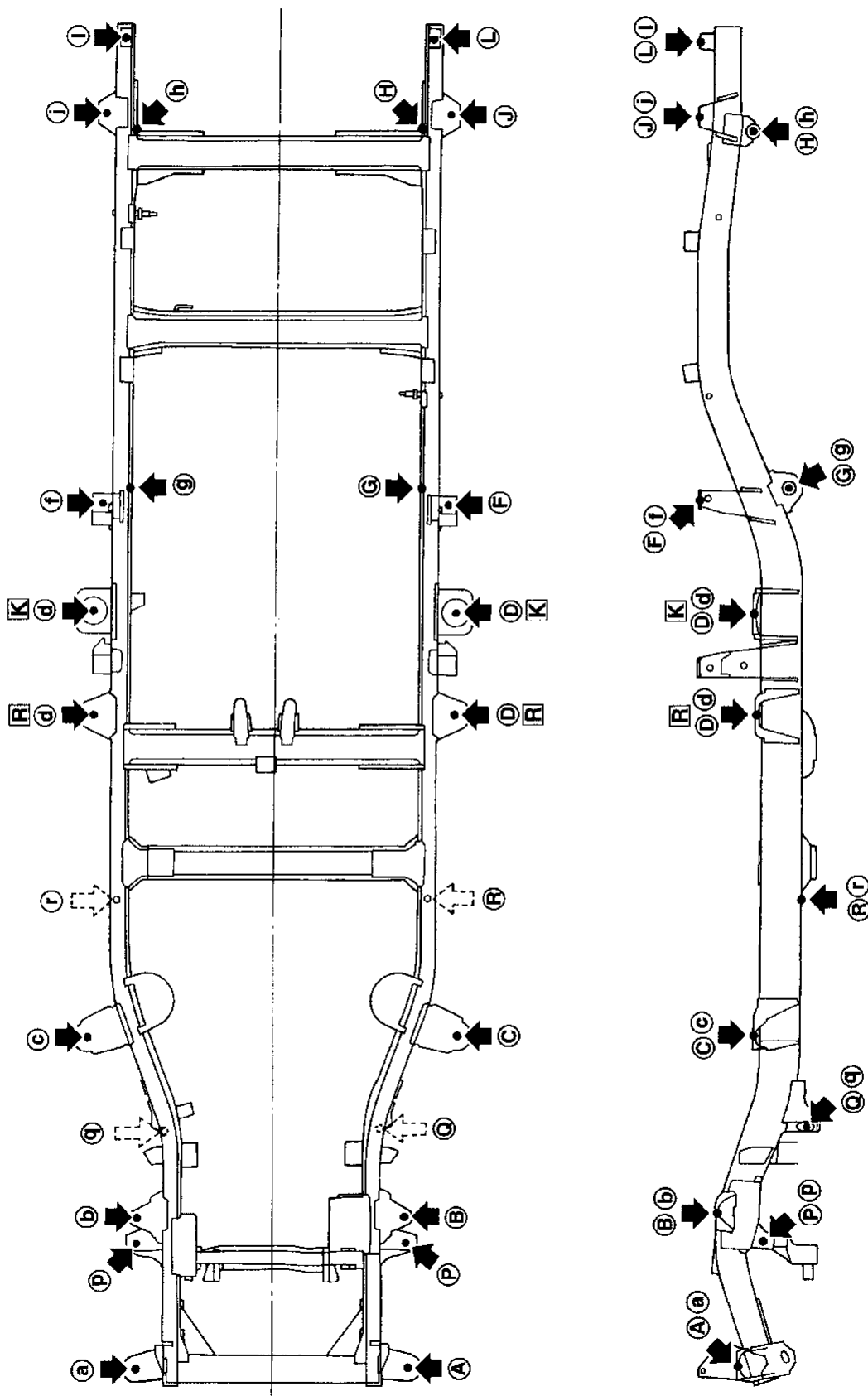

- GI
- MA
- EM
- LC
- EC
- FE
- CL
- MT
- AT
- TF
- PD
- FA
- RA
- BR
- ST
- RS
- BT**
- HA
- EL
- IDX

# BODY ALIGNMENT

## Underbody (Cont'd)

### MEASUREMENT

#### 2WD models

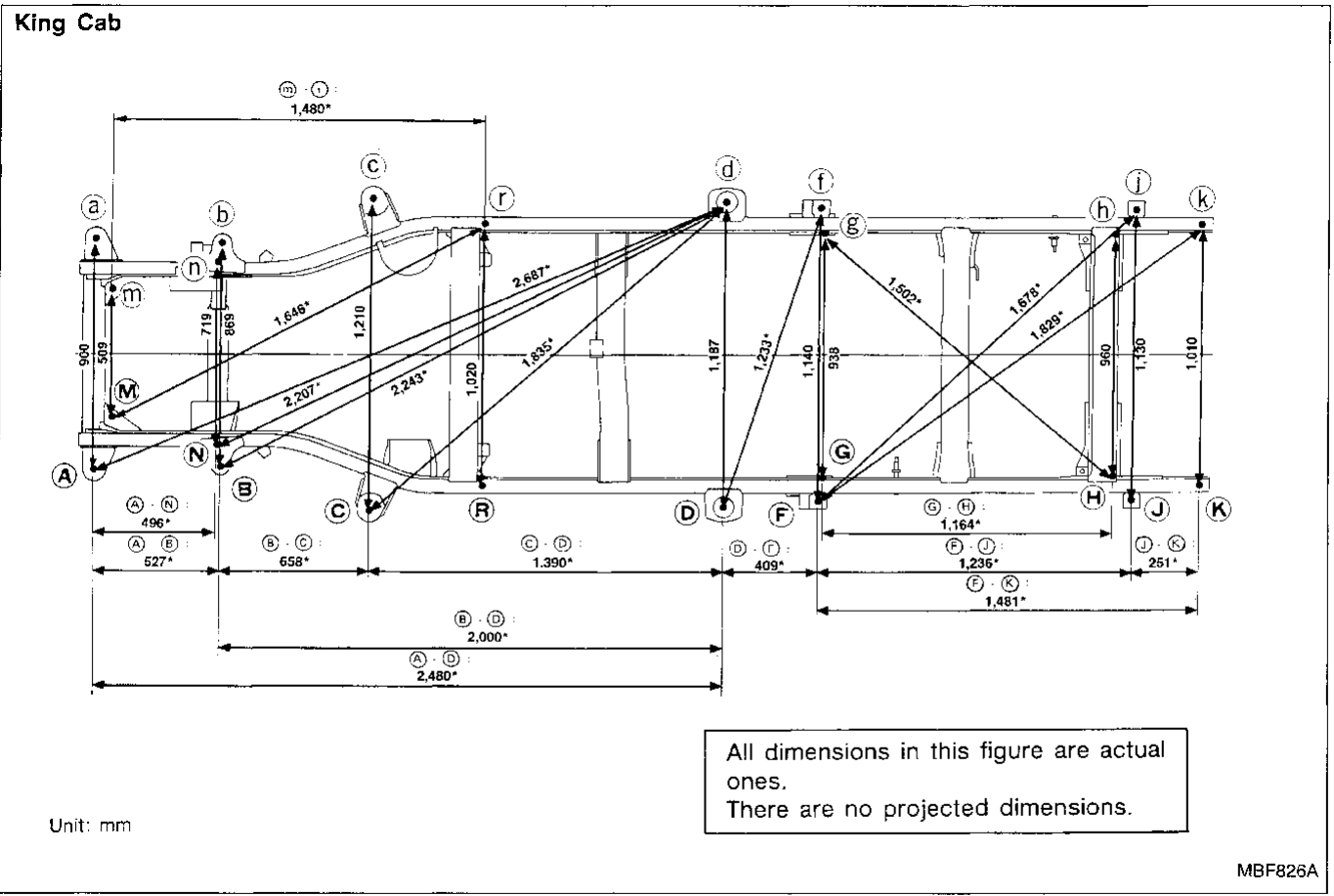
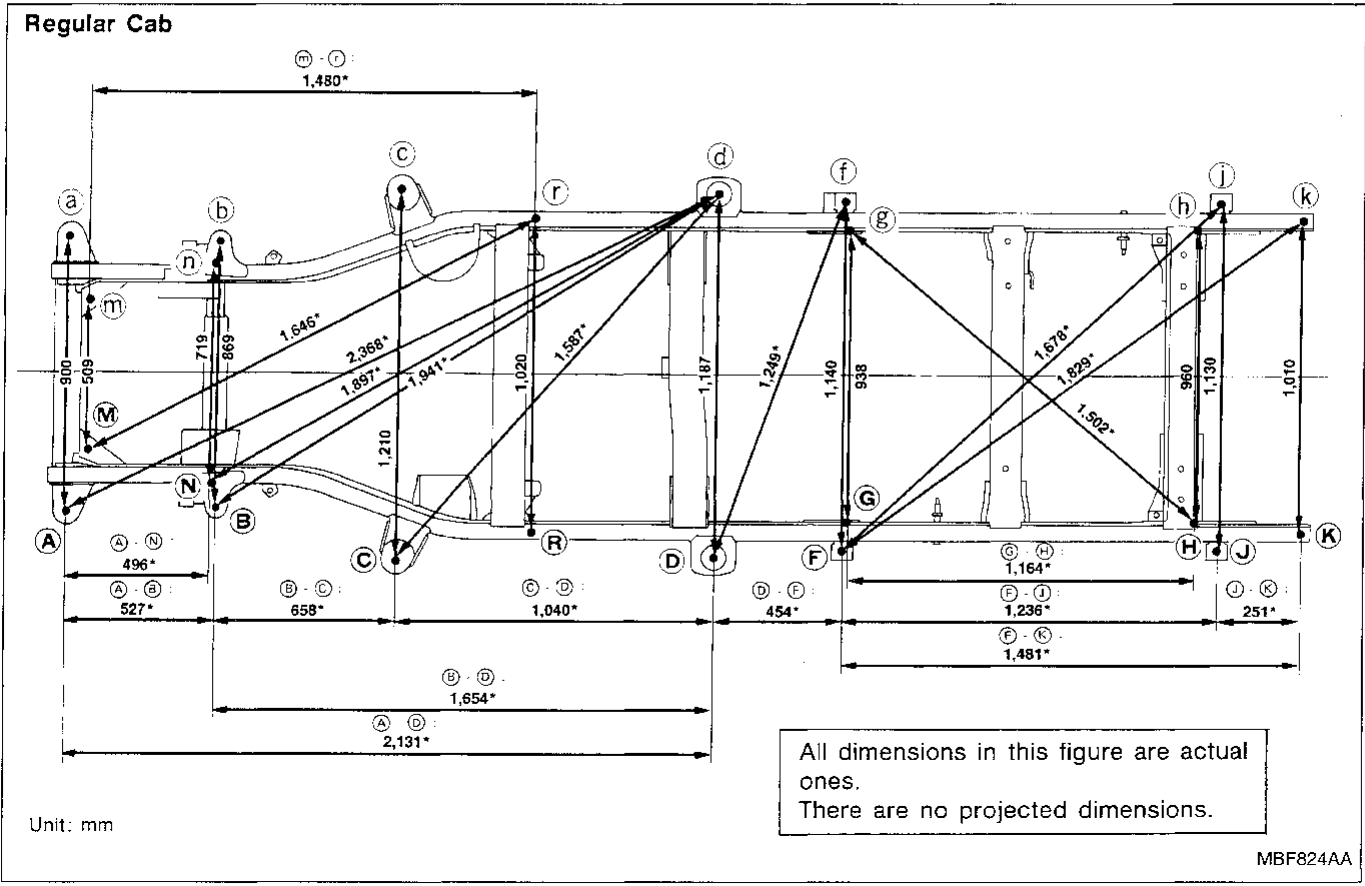

# BODY ALIGNMENT

## Underbody (Cont'd)

### 4WD models

#### Regular Cab

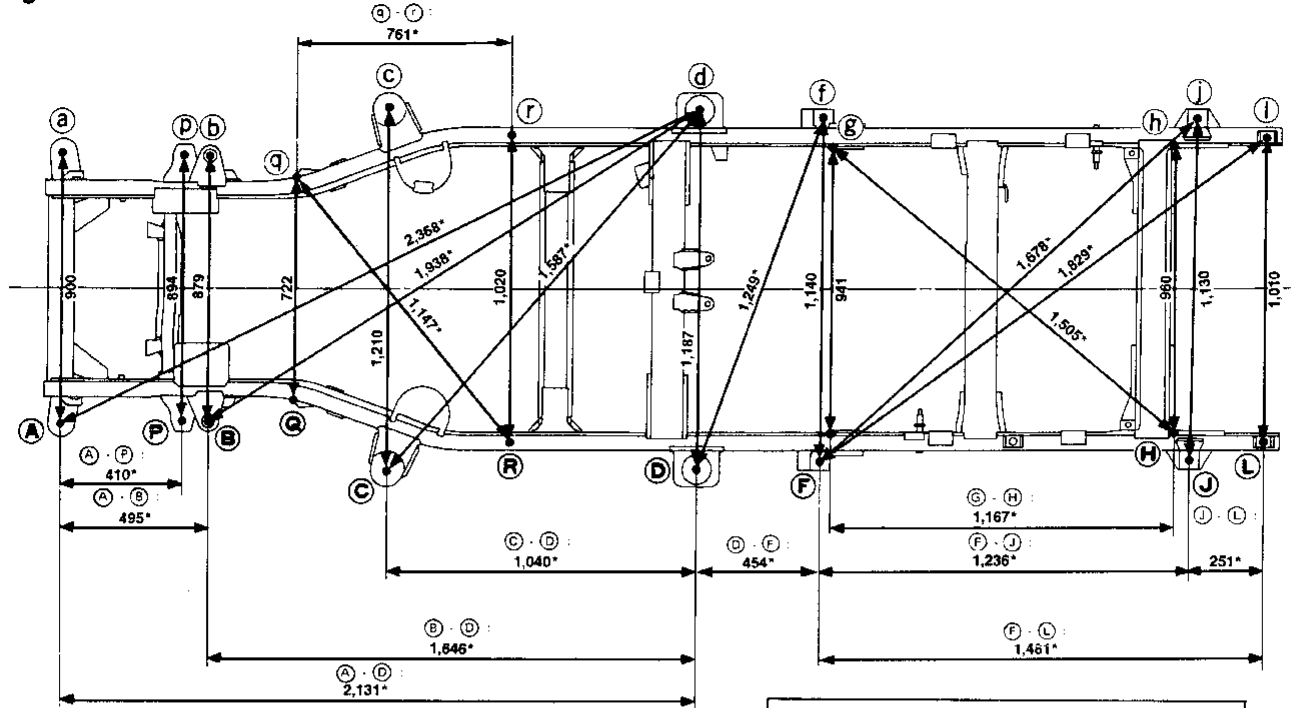

Unit: mm

All dimensions in this figure are actual ones.  
There are no projected dimensions.

MBF827AA

#### King Cab

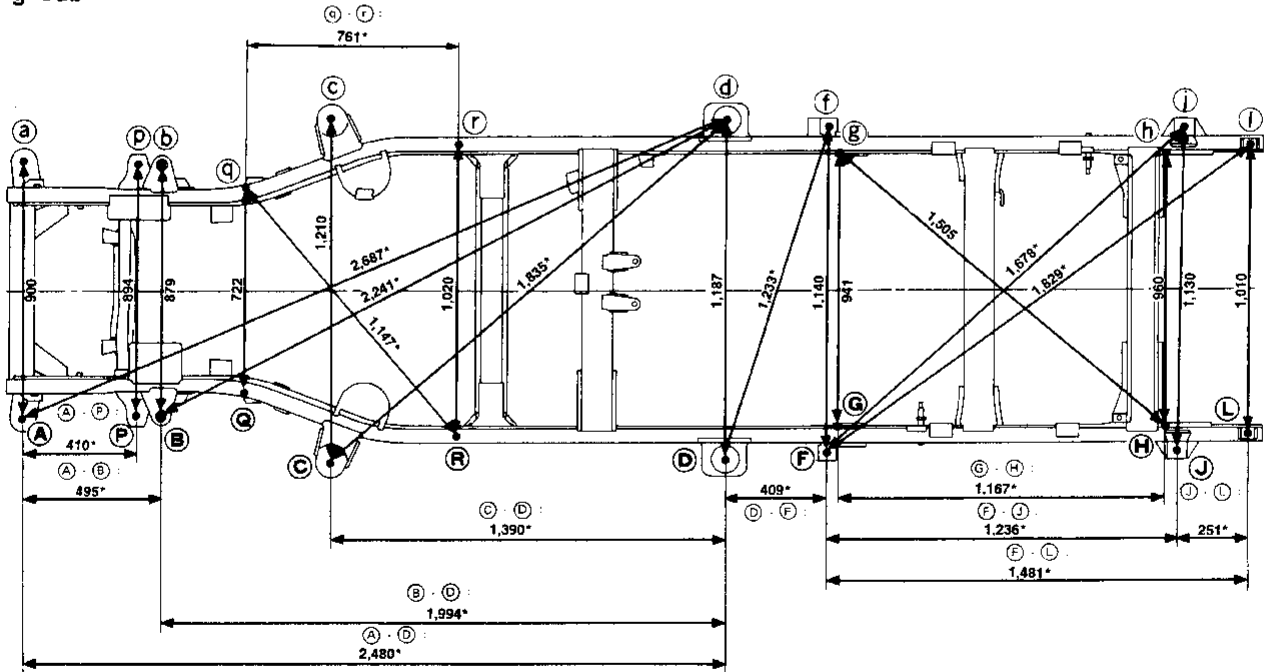

Unit: mm

All dimensions in this figure are actual ones.  
There are no projected dimensions.

MBF829A

GI  
MA  
EM  
LC  
EC  
FE  
CL  
MT  
AT  
TF  
PD  
FA  
RA  
BR  
ST  
RS  
BT  
HA  
EL  
IDX

# BODY ALIGNMENT

## Underbody (Cont'd)

### DETAILED MEASUREMENT POINTS

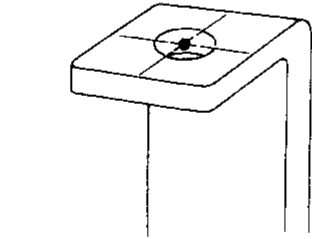
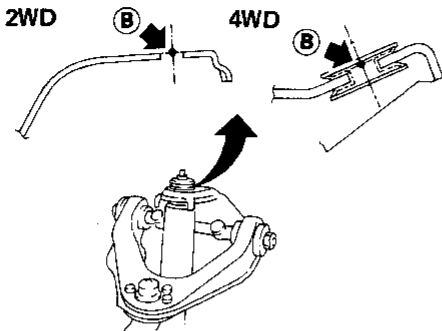
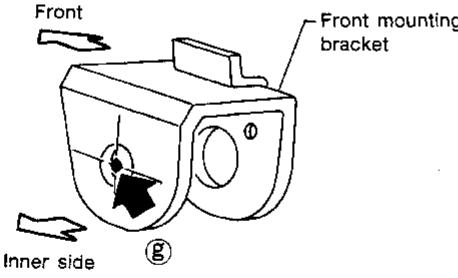
Points	Hole dia. mm	Detailed points	Coordinates mm			
			"x"	"y"	"z"	
(A) (a)	24	 <p style="text-align: center;">Center of hole on top of bracket</p> <p style="text-align: right;">SBF274B</p>	Cab body or rear body mounting insulator mounting hole	450.0	-488.5	<div style="border: 1px solid black; padding: 2px;">2W</div> : 21.2 <div style="border: 1px solid black; padding: 2px;">4W</div> : 71.2
(C) (c)	28			605.0	597.5	<div style="border: 1px solid black; padding: 2px;">2W</div> : -28.2 <div style="border: 1px solid black; padding: 2px;">4W</div> : 21.8
(D) (d)	85			593.5	<div style="border: 1px solid black; padding: 2px;">R</div> : 1,637.0 <div style="border: 1px solid black; padding: 2px;">K</div> : 1,987.0	<div style="border: 1px solid black; padding: 2px;">2W</div> : -15.0 <div style="border: 1px solid black; padding: 2px;">4W</div> : 35.0
(F) (f)	18			570.0	<div style="border: 1px solid black; padding: 2px;">SB</div> : 2,050.0 <div style="border: 1px solid black; padding: 2px;">LB</div> : 2,350.0	<div style="border: 1px solid black; padding: 2px;">2W</div> : 171.8 <div style="border: 1px solid black; padding: 2px;">4W</div> : 221.8
(J) (j)	18			565.0	<div style="border: 1px solid black; padding: 2px;">SB</div> : 3,286.0 <div style="border: 1px solid black; padding: 2px;">LB</div> : 3,586.0	<div style="border: 1px solid black; padding: 2px;">2W</div> : 171.8 <div style="border: 1px solid black; padding: 2px;">4W</div> : 221.8
(L) (l)	22	505.0	<div style="border: 1px solid black; padding: 2px;">SB</div> : 3,530.0 <div style="border: 1px solid black; padding: 2px;">LB</div> : 3,830.0	220.0		
(B) (b)	<div style="border: 1px solid black; padding: 2px;">2W</div> : 15 <div style="border: 1px solid black; padding: 2px;">4W</div> : 15.3	 <p style="text-align: right;">SBF668C</p>	Hole for front shock absorber mounting at the bracket	<div style="border: 1px solid black; padding: 2px;">2W</div> : 434.7 <div style="border: 1px solid black; padding: 2px;">4W</div> : 439.7	<div style="border: 1px solid black; padding: 2px;">2W</div> : 5.6 <div style="border: 1px solid black; padding: 2px;">4W</div> : 1.4	<div style="border: 1px solid black; padding: 2px;">2W</div> : 203.2 <div style="border: 1px solid black; padding: 2px;">4W</div> : 142.0
(G) (g)	12	 <p style="text-align: right;">SBF795G</p>	Hole for rear spring front mounting at the bracket	<div style="border: 1px solid black; padding: 2px;">2W</div> : 469.0 <div style="border: 1px solid black; padding: 2px;">4W</div> : 470.5	<div style="border: 1px solid black; padding: 2px;">2W.SB</div> : 2,059.0 <div style="border: 1px solid black; padding: 2px;">2W.LB</div> : 2,359.0 <div style="border: 1px solid black; padding: 2px;">4W.SB</div> : 2,080.0 <div style="border: 1px solid black; padding: 2px;">4W.LB</div> : 2,380.0	<div style="border: 1px solid black; padding: 2px;">2W</div> : -152.0 <div style="border: 1px solid black; padding: 2px;">4W</div> : -86.0

# BODY ALIGNMENT

## Underbody (Cont'd)

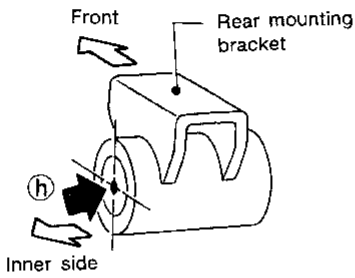
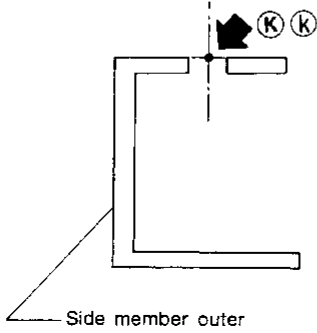
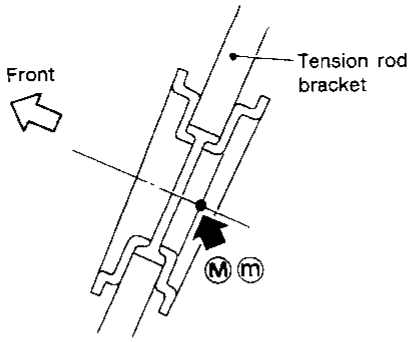
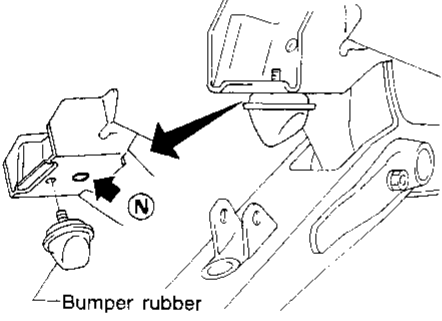
Points	Hole dia. mm	Detailed points	Coordinates mm		
			"x"	"y"	"z"
(H) (h)	33	 <p style="text-align: right;">SBF796G</p>	480.0	<div style="border: 1px solid black; padding: 2px;">2W.SB</div> : 3,209.0 <div style="border: 1px solid black; padding: 2px;">2W.LB</div> : 3,509.0 <div style="border: 1px solid black; padding: 2px;">4W.SB</div> : 3,240.0 <div style="border: 1px solid black; padding: 2px;">4W.LB</div> : 3,540.0	<div style="border: 1px solid black; padding: 2px;">2W</div> : 30.0 <div style="border: 1px solid black; padding: 2px;">4W</div> : 43.0
(K) (k)	22	 <p style="text-align: right;">SBF797G</p>	505.0	<div style="border: 1px solid black; padding: 2px;">SB</div> : 3,530.0 <div style="border: 1px solid black; padding: 2px;">LB</div> : 3,830.0	170.0
(M) (m)	27	 <p style="text-align: right;">SBF798G</p>	254.6	-417.1	-92.3
(N) (n)	9	 <p style="text-align: right;">SBF799G</p>	359.5	-3.2	-23.5

GI  
MA  
EM  
LC  
EC  
FE  
CL  
MT  
AT  
TF  
PD  
FA  
RA  
BR  
ST  
RS  
BT  
HA  
EL  
IDX

# BODY ALIGNMENT

## Underbody (Cont'd)

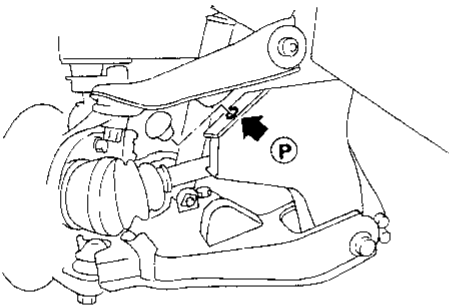
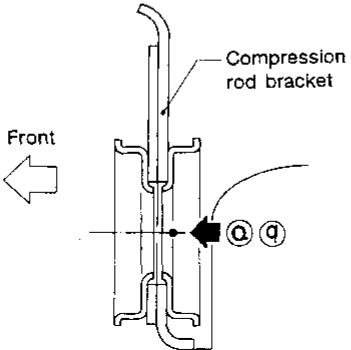
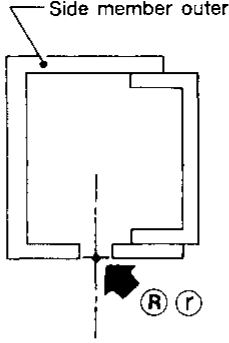
Points	Hole dia. mm	Detailed points		Coordinates mm		
				"x"	"y"	"z"
Ⓟ Ⓟ	10.5	 <p style="text-align: right;">SBF800G</p>	Hole for rebound bumper mounting at lower link bracket	447.0	-88.0	-14.9
Ⓠ Ⓠ	27	 <p style="text-align: right;">SBF801G</p>	Hole for compression rod mounting at the bracket	361.1	294.5	-158.9
Ⓡ Ⓡ	13	 <p style="text-align: right;">SBF802G</p>	Hole for waxing at lower side of side member outer	510.0	1,040.0	-135.0