

HARBORFRONT

BRAKE SYSTEM

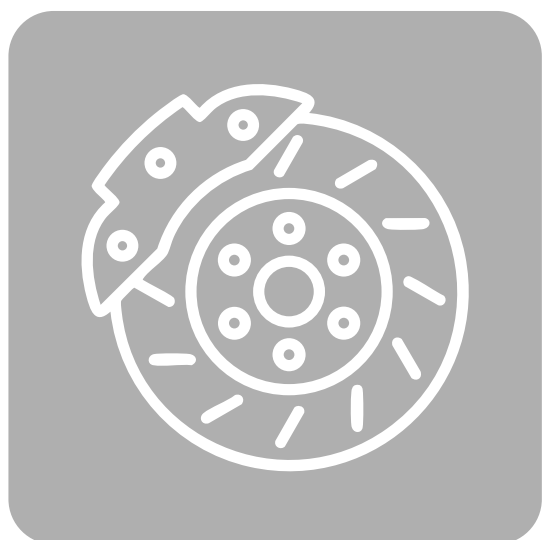

SECTION BR

CONTENTS

PRECAUTIONS AND PREPARATION2	REAR WHEEL ANTI-LOCK BRAKE SYSTEM30
Supplemental Restraint System (SRS) "AIR BAG".....2	Purpose.....30
Commercial Service Tools.....3	Operation.....30
CHECK AND ADJUSTMENT4	System Description.....30
Checking Brake Fluid Level.....4	System Components.....31
Checking Brake Line.....4	Hydraulic Circuit.....31
Changing Brake Fluid.....4	Removal and Installation.....32
AIR BLEEDING5	TROUBLE DIAGNOSES33
Bleeding Procedure.....5	How to Perform Trouble Diagnoses for Quick and Accurate Repair.....33
BRAKE HYDRAULIC LINE6	Symptom Chart.....34
CONTROL VALVE8	Preliminary Check 1.....35
Proportioning Valve (4WD).....8	Self-diagnosis.....36
Load Sensing Valve (2WD).....9	Component Parts and Harness Connector Location.....37
BRAKE PEDAL AND BRACKET11	Circuit Diagram.....38
Adjustment.....12	Wiring Diagram -ABS-.....39
MASTER CYLINDER13	Diagnostic Procedures.....41
BRAKE BOOSTER16	Electrical Components Inspection.....49
On-vehicle Service.....16	SERVICE DATA AND SPECIFICATIONS (SDS)50
VACUUM HOSE18	General Specifications.....50
FRONT DISC BRAKE19	Inspection and Adjustment.....51
Pad Replacement.....19	
REAR DRUM BRAKE24	
PARKING BRAKE CONTROL28	
Adjustment.....29	

When you read wiring diagrams:

- Read G1 section, "HOW TO READ WIRING DIAGRAMS".
- See EL section, "POWER SUPPLY ROUTING" for power distribution circuit.

When you perform trouble diagnoses, read G1 section, "HOW TO FOLLOW FLOW CHART IN TROUBLE DIAGNOSES" and "HOW TO PERFORM EFFICIENT DIAGNOSIS FOR AN ELECTRICAL INCIDENT".

G1

MA

EM

LC

EC

FE

CL

MT

AT

TF

PD

FA

RA

BR

ST

RS

BT

HA

EL

IDX

Supplemental Restraint System (SRS) "AIR BAG"

The Supplemental Restraint System "Air Bag", used along with a seat belt, helps to reduce the risk or severity of injury to the driver in a frontal collision. The Supplemental Restraint System consists of an air bag module (located in the center of the steering wheel), a diagnosis sensor unit, warning lamp, wiring harness, a crash zone sensor (4WD models) and spiral cable. Information necessary to service the system safely is included in the **RS section** of this Service Manual.

WARNING:

- To avoid rendering the SRS inoperative, which could increase the risk of personal injury or death in the event of a collision which would result in air bag inflation, all maintenance must be performed by an authorized NISSAN dealer.
- Improper maintenance, including incorrect removal and installation of the SRS, can lead to personal injury caused by unintentional activation of the system.
- Do not use electrical test equipment on any circuit related to the SRS unless instructed to in this Service Manual. SRS wiring harnesses are covered with yellow insulation either just before the harness connectors or for the complete harness, for easy identification.

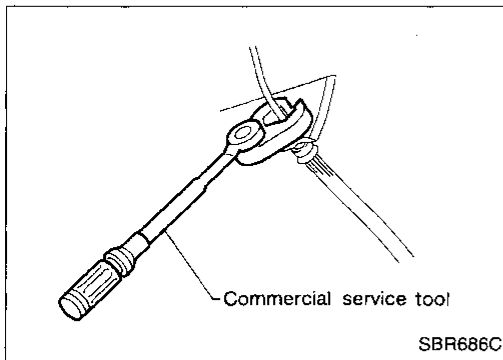

Brake System

- Use brake fluid DOT 3.
- Never reuse drained brake fluid.
- Be careful not to splash brake fluid on painted areas; it may cause paint damage. If brake fluid is splashed on painted areas, wash it away with water immediately.
- To clean master cylinder parts, disc brake caliper parts or wheel cylinder parts, use clean brake fluid.
- Never use mineral oils such as gasoline or kerosene. They will ruin rubber parts of the hydraulic system.
- Use flare nut wrench when removing and installing brake tubes.
- Always torque brake lines when installing.

WARNING:

- Clean brakes with a vacuum dust collector to minimize the hazard of airborne materials.

PRECAUTIONS AND PREPARATION

Commercial Service Tools

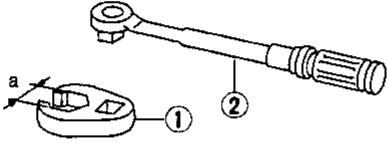
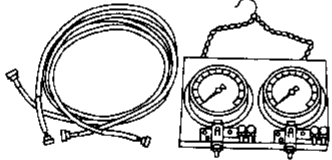
Tool name	Description
<ul style="list-style-type: none"> ① Flare nut crowfoot ② Torque wrench 	<p data-bbox="1019 261 1455 293">Removing and installing each brake piping</p>  <p data-bbox="451 449 513 474">NT360</p> <p data-bbox="1019 449 1219 474">a: 10 mm (0.39 in)</p>
<p data-bbox="151 495 427 527">Brake fluid pressure gauge</p>	<p data-bbox="1019 495 1338 527">Measuring brake fluid pressure</p>  <p data-bbox="451 683 513 708">NT151</p>

GI

MA

EM

LC

EC

FE

CL

MT

AT

TF

PD

FA

RA

BR

ST

RS

BT

HA

EL

IDX

CHECK AND ADJUSTMENT

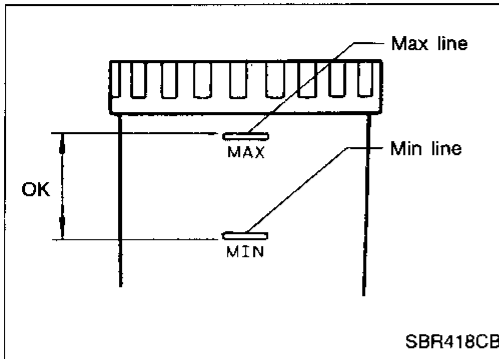

Checking Brake Fluid Level

- Check fluid level in reservoir tank. It should be between Max and Min lines on reservoir tank.
- If fluid level is extremely low, check brake system for leaks.
- If the brake warning lamp comes on, check brake fluid level switch and parking brake switch.

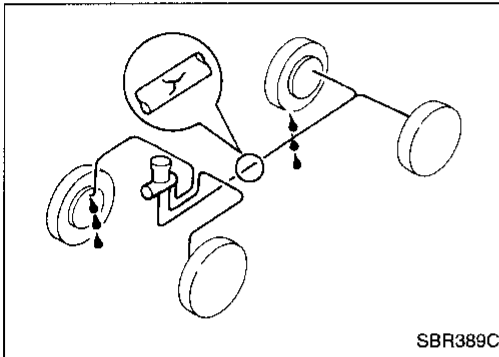

Checking Brake Line

CAUTION:

If leakage occurs around joints, retighten or, if necessary, replace damaged parts.

1. Check brake lines (tubes and hoses) for cracks, deterioration and other damage. Replace any damaged parts.
2. Check for oil leakage by fully depressing brake pedal while engine is running.

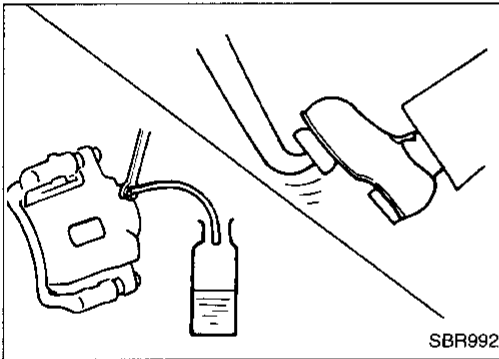

Changing Brake Fluid

CAUTION:

- Refill with new brake fluid DOT 3.
- Always keep fluid level higher than minimum line on reservoir tank.
- Never reuse drained brake fluid.
- Be careful not to splash brake fluid on painted areas; it may cause paint damage. If brake fluid is splashed on painted areas, wash it away with water immediately.

1. Clean inside of reservoir tank, and refill with new brake fluid.
2. Connect a vinyl tube to each air bleeder valve.
3. Drain brake fluid from each air bleeder valve by depressing brake pedal.
4. Refill until brake fluid comes out of each air bleeder valve. Use same procedure as in bleeding hydraulic system to refill brake fluid. Refer to "Bleeding Procedure", BR-5.

AIR BLEEDING

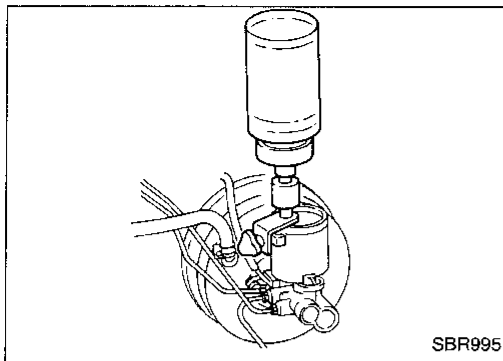

Bleeding Procedure

CAUTION:

- Carefully monitor brake fluid level at master cylinder during bleeding operation.
- If master cylinder is suspected to have air inside, bleed air from master cylinder first. Refer to "Installation", "MASTER CYLINDER", BR-15.
- Fill reservoir with new brake fluid DOT 3. Make sure it is full at all times while bleeding air out of system.
- Place a container under master cylinder to avoid spillage of brake fluid.
- Rear Wheel Anti-Lock Brake system:
Before bleeding air, be sure to turn ignition switch OFF and disconnect battery ground cable and actuator connector.
- Bleed air in the following order.
 - a. LSV air bleeder (Models equipped with LSV)
 - b. Left rear brake
 - c. Right rear brake
 - d. Left front brake
 - e. Right front brake
 - f. ABS actuator

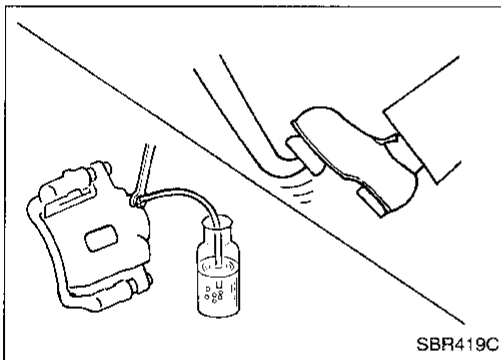

1. Connect a transparent vinyl tube to air bleeder valve.
2. Fully depress brake pedal several times.
3. With brake pedal depressed, open air bleeder valve to release air.
4. Close air bleeder valve.
5. Release brake pedal slowly.
6. Repeat steps 2 through 5 until clear brake fluid comes out of air bleeder valve.
7. Tighten air bleeder to the specified torque.
🔧: 7 - 9 N·m (0.7 - 0.9 kg-m, 61 - 78 in-lb)

GI

MA

EM

LC

EC

FE

CL

MT

AT

TF

PD

FA

RA

BR

ST

RS

BT

HA

EL

IDX

BRAKE HYDRAULIC LINE

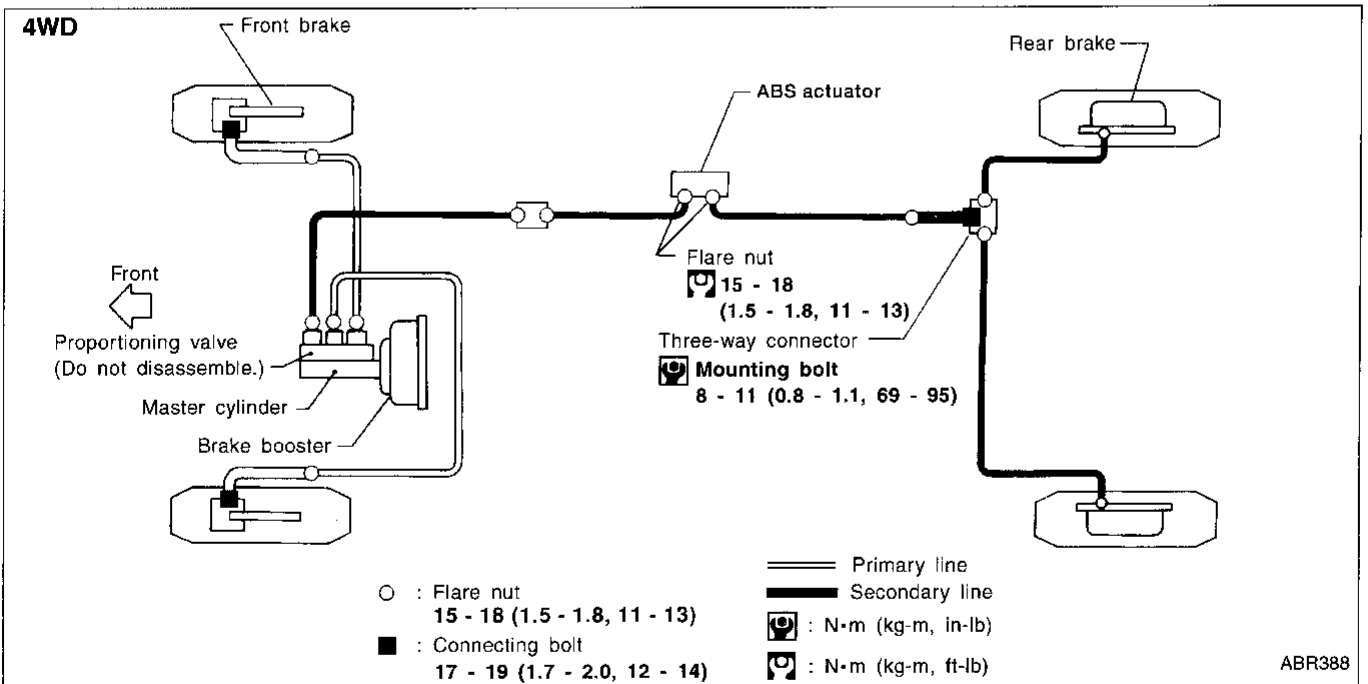
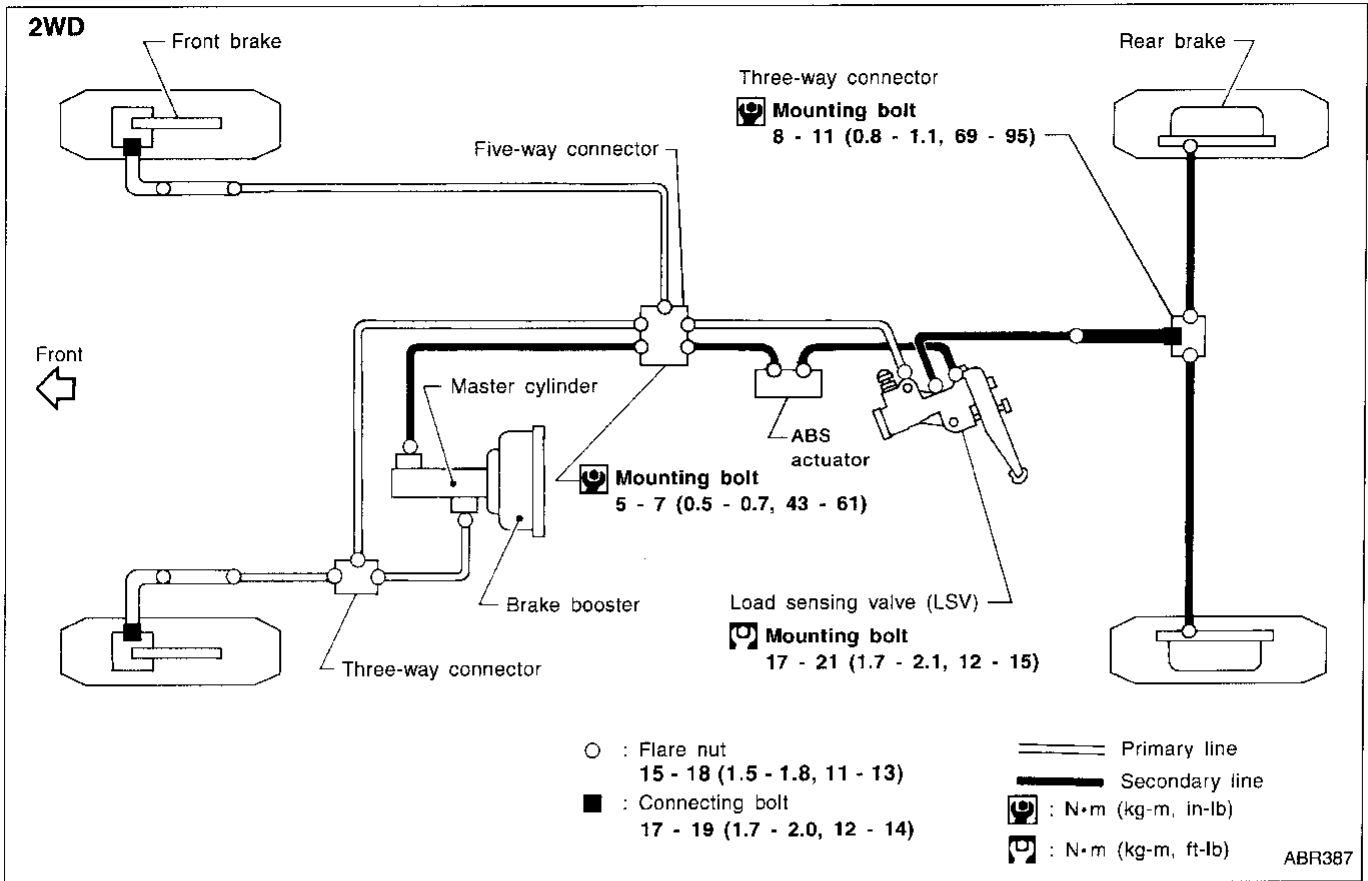

BRAKE HYDRAULIC LINE

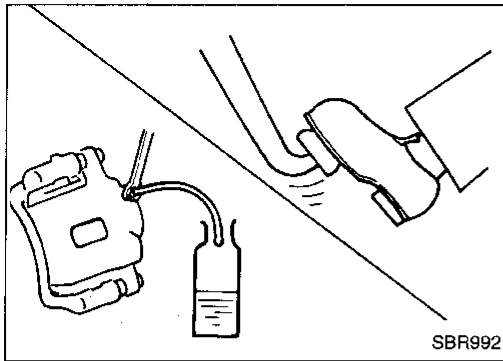

REMOVAL

CAUTION:

- Be careful not to splash brake fluid on painted areas; it may cause paint damage. If brake fluid is splashed on painted areas, wash it away with water immediately.

- All hoses must be free from excessive bending, twisting and pulling.

1. Connect vinyl tube to air bleeder valve.
2. Drain brake fluid from each air bleeder valve by depressing brake pedal.
3. Remove flare nut connecting brake tube and hose, then withdraw lock spring.
4. Cover openings to prevent entrance of dirt whenever disconnecting brake line.

INSPECTION

Check brake lines (tubes and hoses) for cracks, deterioration and other damage. Replace any damaged parts.

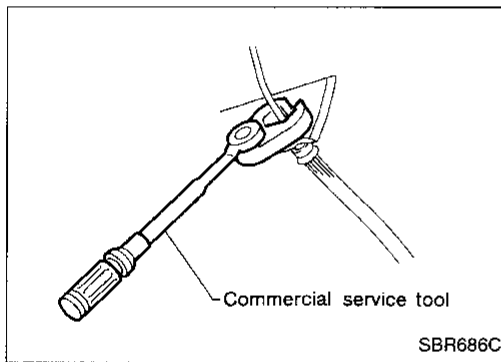

INSTALLATION

CAUTION:

- Refill with new brake fluid DOT 3.
- Never reuse drained brake fluid.

1. Tighten all flare nuts and connecting bolts.

Flare nut:

: 15 - 18 N·m (1.5 - 1.8 kg-m, 11 - 13 ft-lb)

Connecting bolt:

: 17 - 19 N·m (1.7 - 2.0 kg-m, 12 - 14 ft-lb)

2. Refill until new brake fluid comes out of each air bleeder valve.
3. Bleed air. Refer to "Bleeding Procedure", BR-5.

GI

MA

EM

LC

EC

FE

CL

MT

AT

TF

PD

FA

RA

BR

ST

RS

BT

HA

EL

IDX

CONTROL VALVE

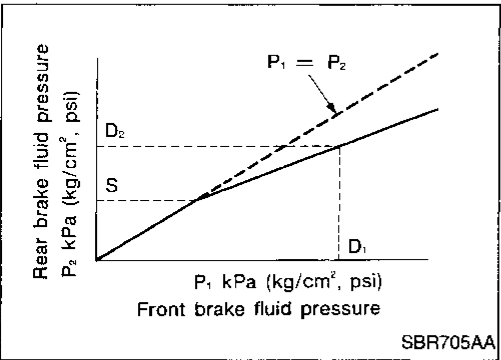
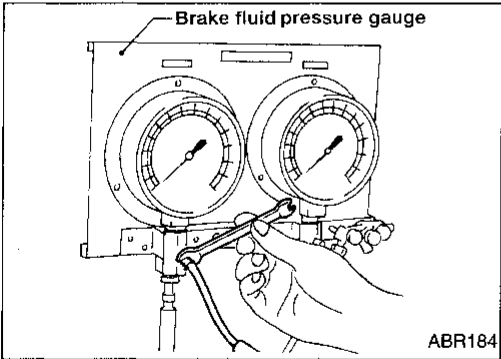
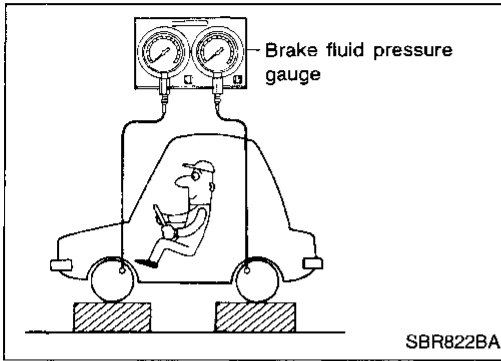

Proportioning Valve (4WD)

INSPECTION

CAUTION:

- Carefully monitor brake fluid level at master cylinder.
- Use new brake fluid DOT 3.
- Be careful not to splash brake fluid on painted areas; it may cause paint damage. If brake fluid is splashed on paint areas, wash it away with water immediately.
- Depress pedal slowly when raising front brake pressure.
- Check rear brake pressure 2 seconds after front brake pressure reaches specified value.
- Disconnect ABS harness connectors from ABS actuator relay box before checking.

1. Connect Tool to air bleeders of front and rear brakes on either LH or RH side.
2. Bleed air from the Tool.
3. Check fluid pressure by depressing brake pedal.

Unit: kPa (kg/cm², psi)

Wheelbase	Standard	Long
Applied pressure (Front brake) D_1	5,884 (60, 853)	6,375 (65, 924)
Output pressure (Rear brake) D_2	2,942 - 3,334 (30 - 34, 427 - 483)	3,432 - 3,825 (35 - 39, 498 - 555)

If output pressure is out of specifications, replace master cylinder assembly (built-in type).

4. Bleed air after disconnecting the Tool. Refer to "Bleeding Procedure", BR-5.

REMOVAL AND INSTALLATION (Built-in type)

- Always replace proportioning valve and master cylinder as an assembly.
- Refer to "Removal", "MASTER CYLINDER", BR-13.

CONTROL VALVE

Load Sensing Valve (2WD) (Cont'd)

INSPECTION

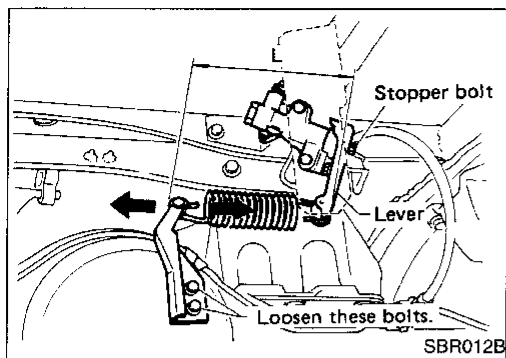

1. Ensure vehicle is unladen condition*.
 - * Fuel, radiator coolant and engine oil full. Spare tire, jack, hand tools and mats in designated positions.
2. Have a driver sit in the driver's seat and one person sit on the rear of the vehicle. Then have the person on the rear of the vehicle slowly get off. This is necessary to stabilize suspension deflection.
3. Adjust length "L" as follows:
 - a. Loosen stopper bolt locknut.
 - b. Pull lever against stopper bolt and adjust by turning stopper bolt.
 - c. Tighten stopper bolt locknut.

Length "L":

Approx. 189 mm (7.44 in)

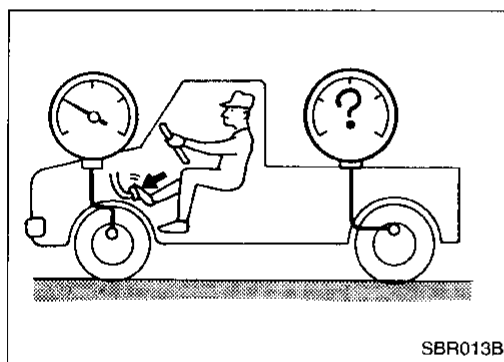

4. Install pressure gauge on front and rear brake.
5. Bleed air from the Tool.
6. Raise front brake pressure to 5,884 kPa (60 kg/cm², 853 psi) and 9,807 kPa (100 kg/cm², 1,422 psi) and check rear brake pressure.

Rear brake pressure:

Refer to table below.

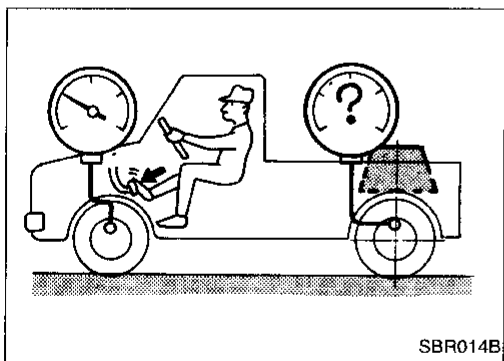

7. Set down weight slowly over axle center so that sensor spring length becomes the same as when in loaded condition (refer to table below). Check rear brake pressure in the same way described in step 6.

Unit: kPa (kg/cm², psi)

	U.S.A.	Canada
Without weight	2,942 - 3,727 (30 - 38, 427 - 540)	2,942 - 3,727 (30 - 38, 427 - 540)
With weight	3,432 - 4,805 (35 - 49, 498 - 697)	3,334 - 4,707 (34 - 48, 483 - 683)

BRAKE PEDAL AND BRACKET

Removal and Installation

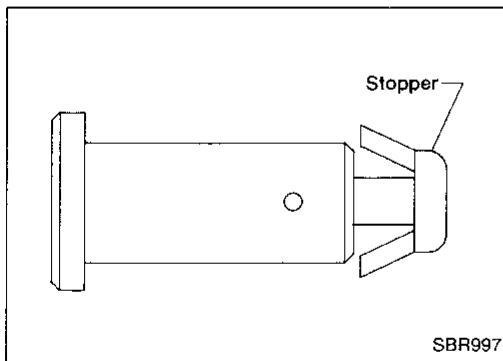
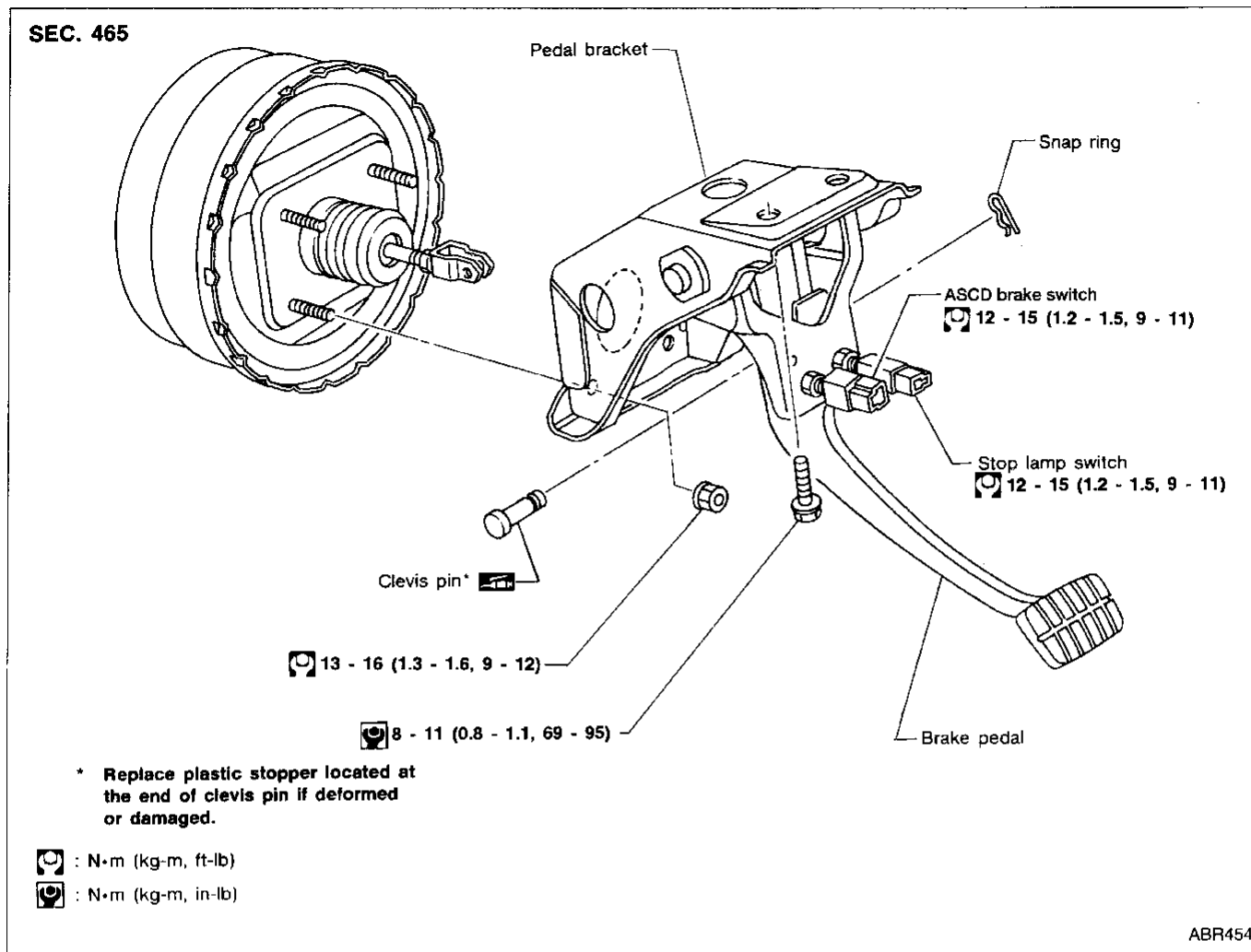

Inspection

Check brake pedal for following items:

- Brake pedal bend
- Clevis pin deformation
- Crack of any welded portion
- Crack or deformation of clevis pin stopper

GI
MA
EM
LC
EC
FE
CL
MT
AT
TF
PD
FA
RA
BR
ST
RS
BT
HA
EL
IDX

BRAKE PEDAL AND BRACKET

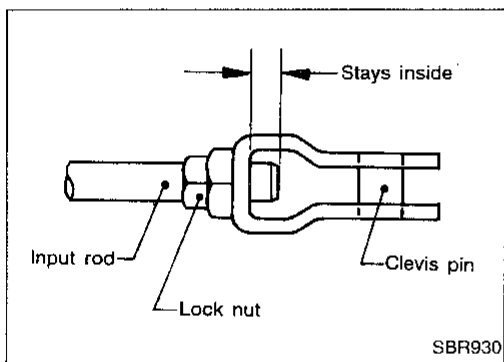
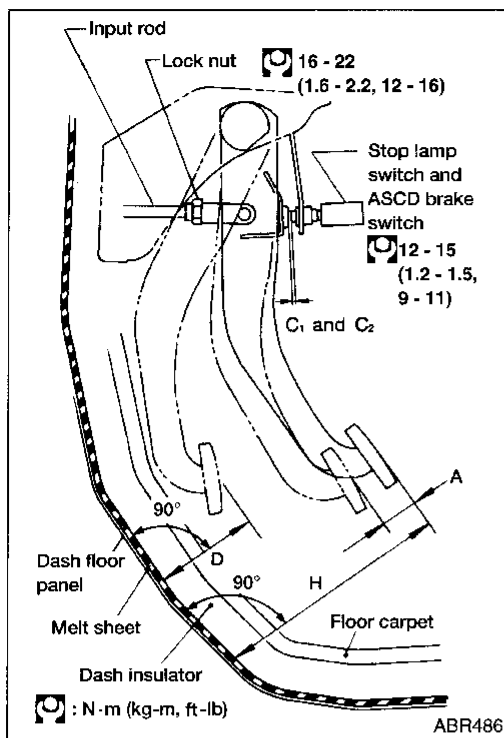

Adjustment

Check brake pedal free height from melt sheet.

H: Free height

Refer to SDS BR-51.

D: Depressed height

Refer to SDS BR-51.

Under force of 490 N (50 kg, 110 lb) with engine running

C₁: Clearance between pedal stopper and threaded end of stop lamp switch
0.3 - 1.0 mm (0.012 - 0.039 in)

C₂: Clearance between pedal stopper and threaded end of ASCD switch
0.3 - 1.0 mm (0.012 - 0.039 in)

A: Pedal free play at clevis
1 - 3 mm (0.04 - 0.12 in)

If necessary, adjust brake pedal free height.

1. Loosen lock nut and adjust pedal free height by turning brake booster input rod. Then tighten lock nut.

- **Make sure that the tip of input rod stays inside.**

2. Loosen lock nut and adjust clearance "C₁" and "C₂" with stop lamp switch and ASCD brake switch respectively. Then tighten lock nuts.

3. Check pedal free play.

- **Make sure that stop lamps are off when pedal is released.**

4. Check depressed height of brake pedal while engine is running. If lower than specification, check for leaks, air in system and damage to components (master cylinder, wheel cylinder, etc.).

MASTER CYLINDER

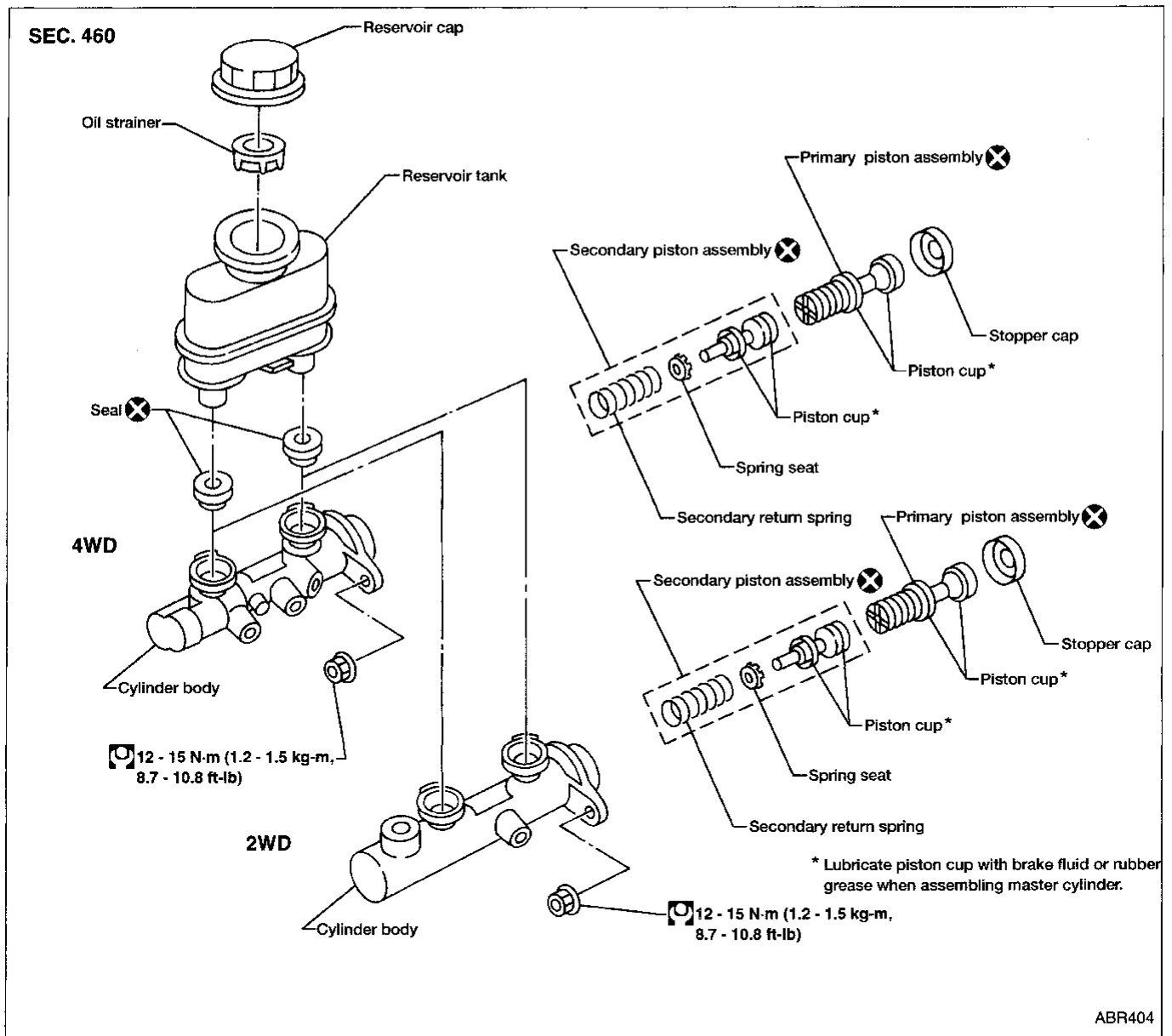

Removal

CAUTION:

- Be careful not to splash brake fluid on painted areas; it may cause paint damage. If brake fluid is splashed on painted areas, wash it away with water immediately.
- In the case of brake fluid leakage from the master cylinder, disassemble the cylinder. Then check piston cups for deformation and scratches and replace necessary parts.

1. Connect a vinyl tube to air bleeder valve.
2. Drain brake fluid from each air bleeder valve, depressing brake pedal to empty fluid from master cylinder.
3. Remove brake pipe flare nuts.
4. Remove master cylinder mounting nuts.

MASTER CYLINDER

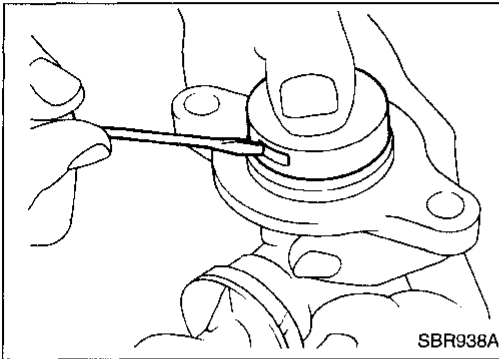

Disassembly

1. Bend claws of stopper cap outward.
2. Remove piston assemblies.
 - If it is difficult to remove secondary piston assembly, gradually apply compressed air through fluid outlet.
3. Draw out reservoir tank.

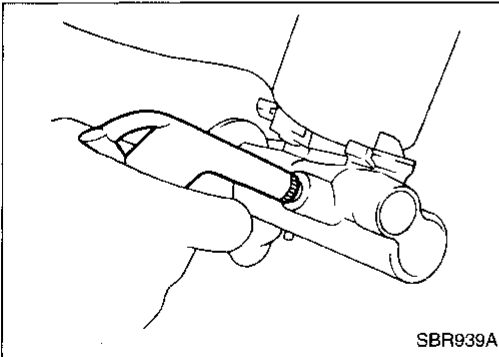

Inspection

Check master cylinder inner wall for pin holes and scratches. Replace if damaged.

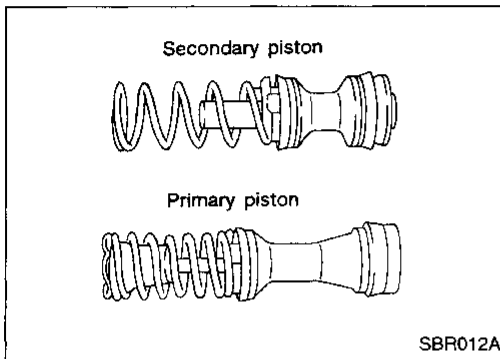

Assembly

1. Insert secondary piston assembly. Then insert primary piston assembly.
 - Pay attention to direction of piston cups in figure at left. Also, insert pistons squarely to avoid scratches on cylinder bore.
2. Install stopper cap.
 - Before installing stopper cap, ensure that claws are bent inward.
3. Push reservoir tank seals into cylinder body.
4. Push reservoir tank into cylinder body.

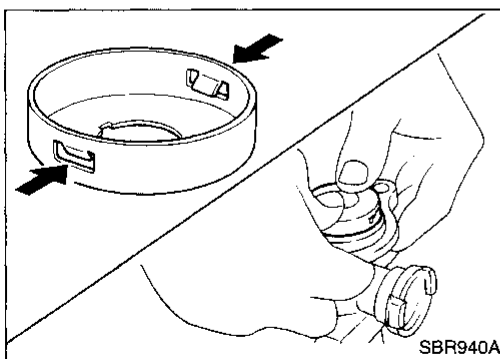

MASTER CYLINDER

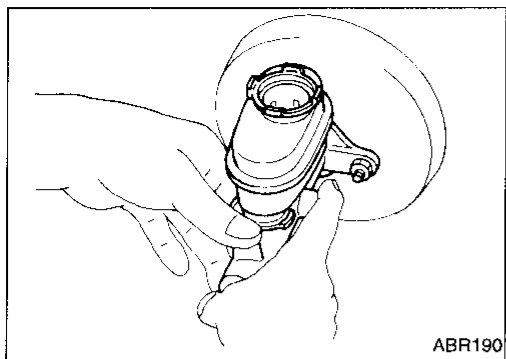

Installation

CAUTION:

- Refill with new brake fluid DOT 3.
 - Never reuse drained brake fluid.
1. Place master cylinder onto brake booster and secure mounting nuts lightly.
 2. Tighten mounting nuts.
⚙️: 12 - 15 N·m (1.2 - 1.5 kg-m, 8.7 - 10.8 ft-lb)
 3. Fill up reservoir tank with new brake fluid.
 4. Plug all ports on master cylinder with fingers to prevent air suction while releasing brake pedal.
 5. Have driver depress brake pedal slowly several times until no air comes out of master cylinder.
 6. Fit brake lines to master cylinder.
 7. Tighten flare nuts.
⚙️: 15 - 18 N·m (1.5 - 1.8 kg-m, 11 - 13 ft-lb)
 8. Bleed air from brake system. Refer to "Bleeding Procedure", BR-5.

GI

MA

EM

LC

EC

FE

CL

MT

AT

TF

PD

FA

RA

BR

ST

RS

BT

HA

EL

IDX

BRAKE BOOSTER

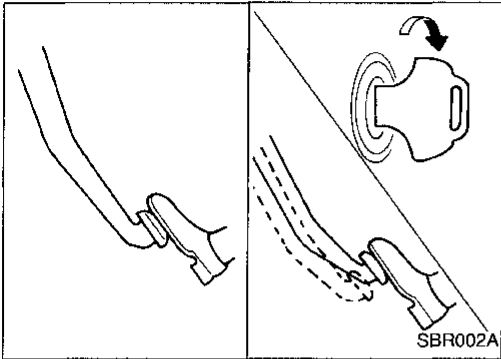

SBR002A

On-vehicle Service

OPERATING CHECK

- Depress brake pedal several times with engine off. After exhausting vacuum, make sure there is no change in pedal stroke.
- Depress brake pedal, then start engine. If pedal goes down slightly, operation is normal.

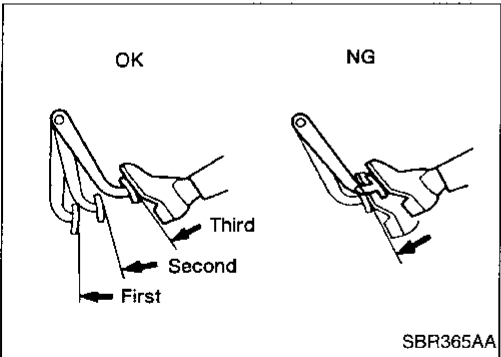

SBR365AA

AIRTIGHT CHECK

- Start engine, and stop it after one or two minutes. Depress brake pedal several times slowly. Booster is airtight if pedal stroke is less each time.
- Depress brake pedal while engine is running, and stop engine with pedal depressed. The pedal position should not change after holding pedal down for **30 seconds**.

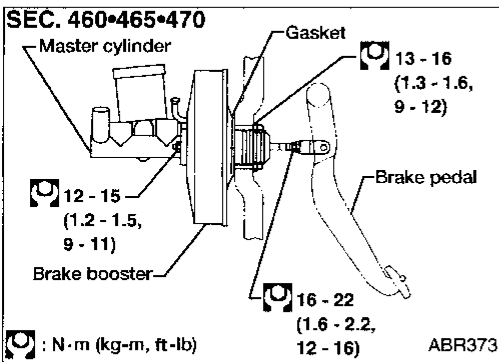

Removal

CAUTION:

- Be careful not to splash brake fluid on painted areas; it may cause paint damage. If brake fluid is splashed on painted areas, wash it away with water immediately.
- Be careful not to deform or bend brake pipes during removal of booster.

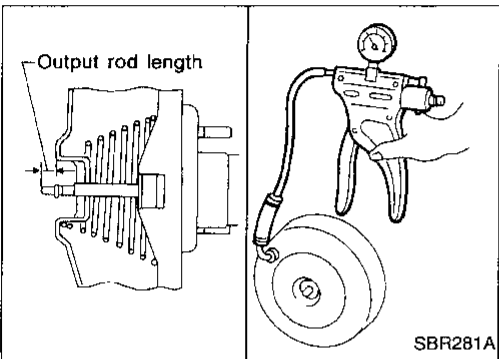

SBR281A

Inspection

OUTPUT ROD LENGTH CHECK

1. Apply vacuum of -66.7 kPa (-500 mmHg, -19.69 inHg) to brake booster with a hand vacuum pump.
2. Check output rod length.

Specified length:

10.275 - 10.525 mm (0.4045 - 0.4144 in)

Installation

CAUTION:

- Be careful not to deform or bend brake pipes during installation of booster.
- Replace clevis pin if damaged.
- Refill with new brake fluid DOT 3.
- Never reuse drained brake fluid.
- Take care not to damage brake booster mounting bolt thread when installing. Due to the narrow angle of installation, the threads can be damaged by the dash panel.

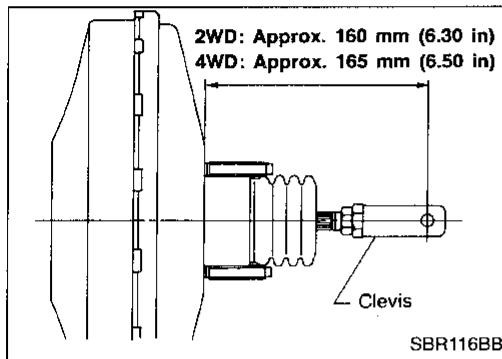

1. Before fitting booster, temporarily adjust clevis to dimension shown.
2. Fit booster, then secure mounting nuts (brake pedal bracket to brake booster) lightly.
3. Connect brake pedal and booster input rod with clevis pin.
4. Secure mounting nuts.
⚠: 13 - 16 N·m (1.3 - 1.6 kg-m, 9 - 12 ft-lb)
5. Install master cylinder. Refer to "Installation", "MASTER CYLINDER", BR-15.
6. Adjust brake pedal height and free play. Refer to BR-12.
7. Secure lock nut for clevis.
⚠: 16 - 22 N·m (1.6 - 2.2 kg-m, 12 - 16 ft-lb)
8. Bleed air. Refer to "Bleeding Procedure", BR-5.

GI

MA

EM

LC

EC

FE

CL

MT

AT

TF

PD

FA

RA

BR

ST

RS

BT

HA

EL

IDX

VACUUM HOSE

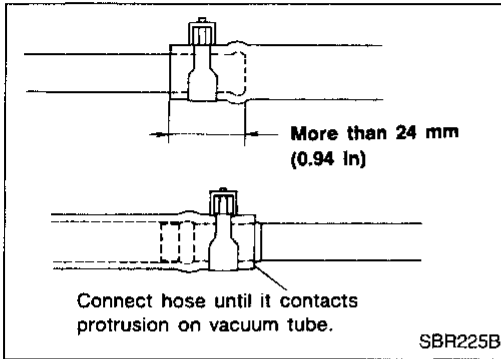

Removal and Installation

CAUTION:

When installing vacuum hoses, pay attention to the following points.

- Do not apply any oil or lubricants to vacuum hose and check valve.
- Insert vacuum tube into vacuum hose as shown.

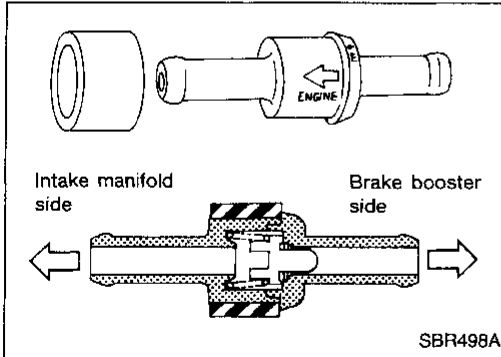

- Install check valve, paying attention to its direction.

Inspection

HOSES AND CONNECTORS

Check vacuum lines, connections and check valve for airtightness, improper attachment chafing and deterioration.

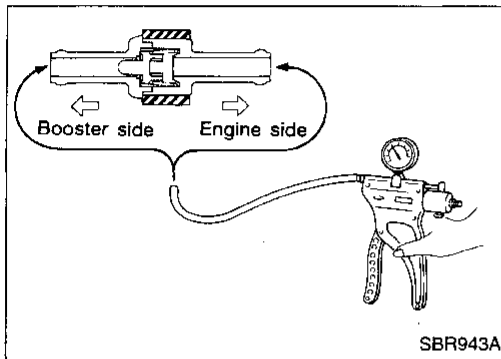

CHECK VALVE

Check vacuum with a vacuum pump.

Connect to booster side	Vacuum should exist.
Connect to engine side	Vacuum should not exist.

FRONT DISC BRAKE

Pad Replacement

WARNING:

Clean brake pads with a vacuum dust collector to minimize the hazard of airborne materials.

CAUTION:

- When cylinder body is open, do not depress brake pedal or caliper piston will pop out.
- Be careful not to damage piston boot or get oil on rotor. Always replace shims when replacing pads.
- If shims are rusted or show peeling of the rubber coat, replace them with new shims.
- It is only necessary to remove connecting bolt if disassembling or replacing caliper assembly. Otherwise, suspend cylinder body with wire so as not to stretch brake hose.

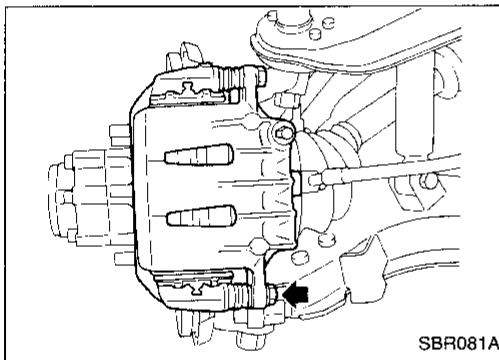

1. Remove master cylinder reservoir cap.
2. Remove lower pin bolt.

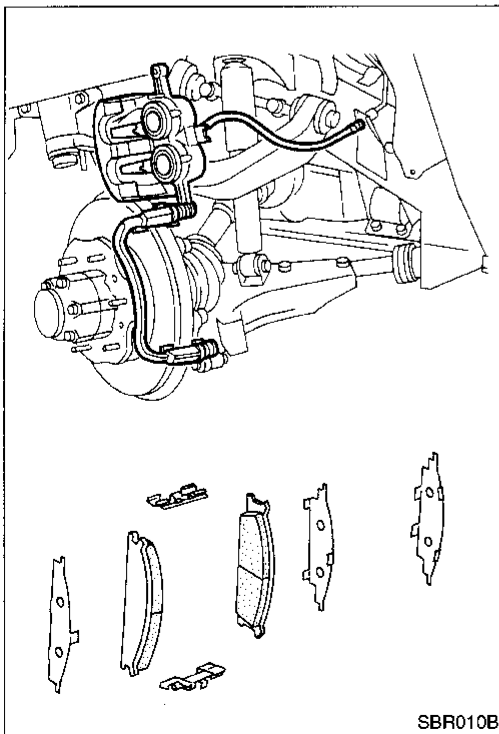

3. Open cylinder body upward. Then remove pad retainers and inner and outer shims.

Standard pad thickness:

CL28VA model

11 mm (0.44 in)

CL28VD model

10 mm (0.39 in)

Pad wear limit:

2.0 mm (0.079 in)

- Carefully monitor brake fluid level because brake fluid will return to reservoir when pushing back piston.

GI

MA

EM

LC

EC

FE

CL

MT

AT

TF

PD

FA

RA

BR

ST

RS

BT

HA

EL

IDX

FRONT DISC BRAKE

CL28VA

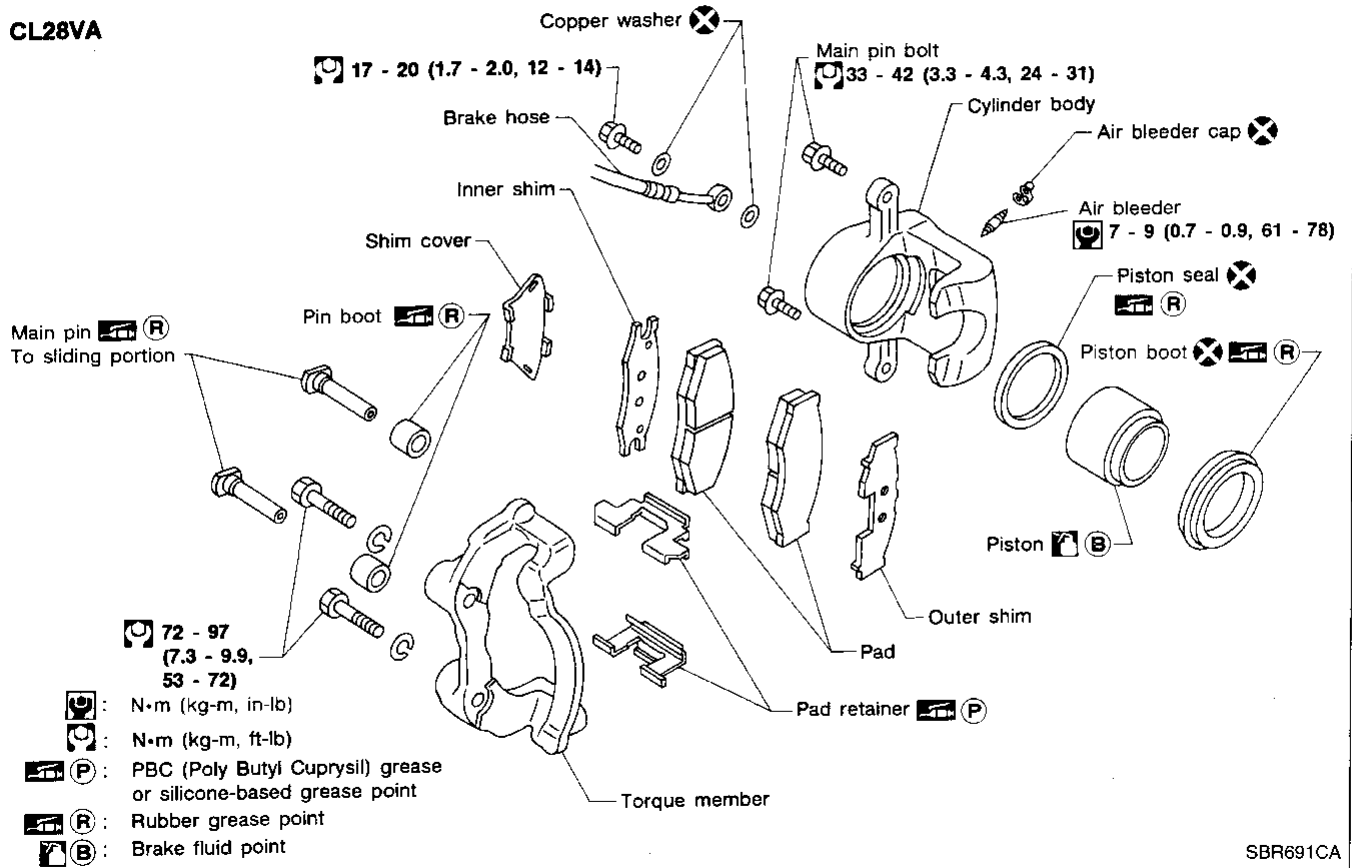

CL28VD

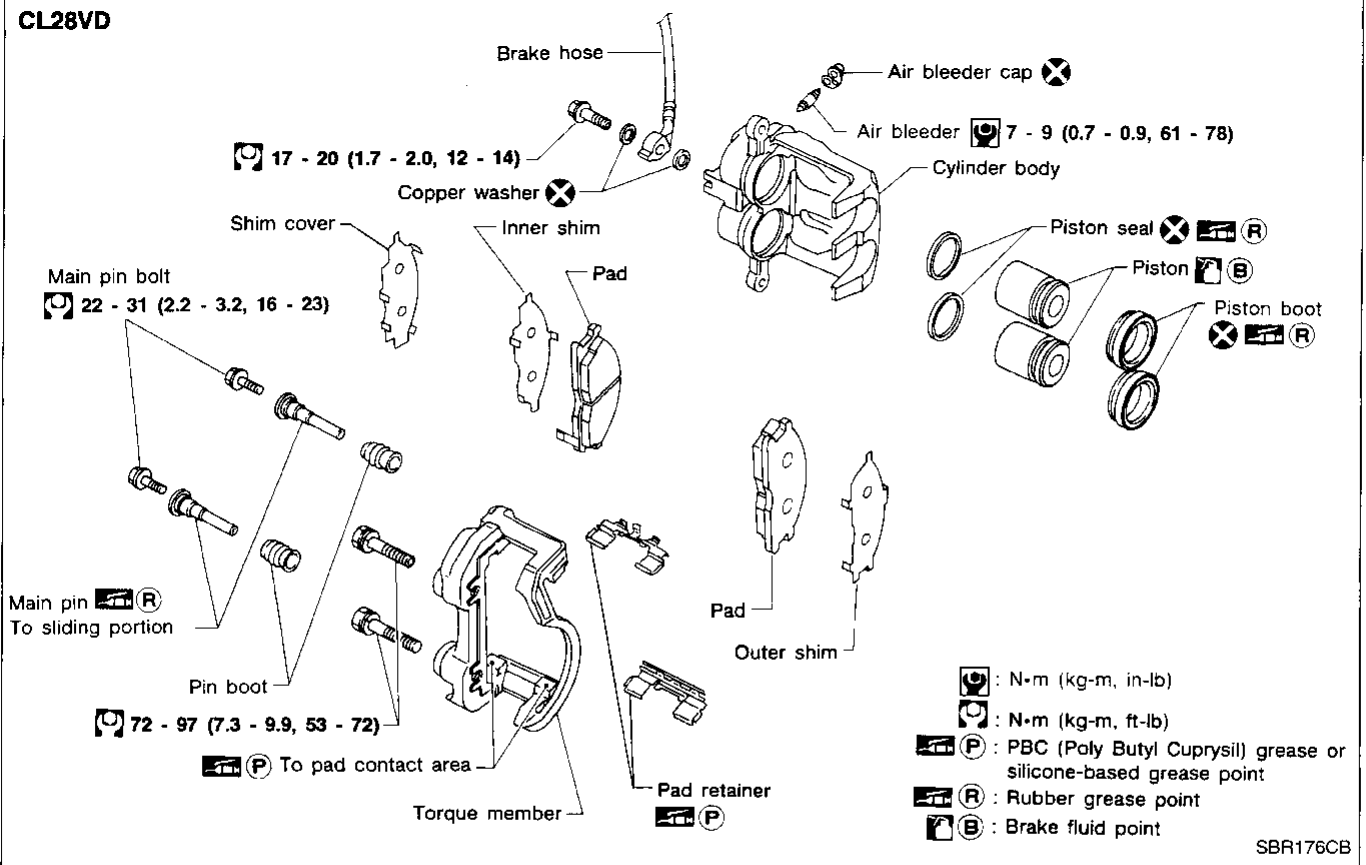

FRONT DISC BRAKE

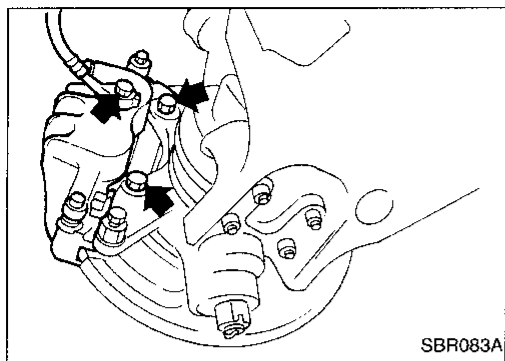

Removal

WARNING:

Clean brake pads with a vacuum dust collector to minimize the hazard of airborne materials.

CAUTION:

Suspend caliper assembly with wire so as not to stretch brake hose.

Remove torque member fixing bolts and connecting bolt.

- It is only necessary to remove connecting bolt if disassembling or replacing caliper assembly. Otherwise, suspend caliper assembly with wire so as not to stretch brake hose.

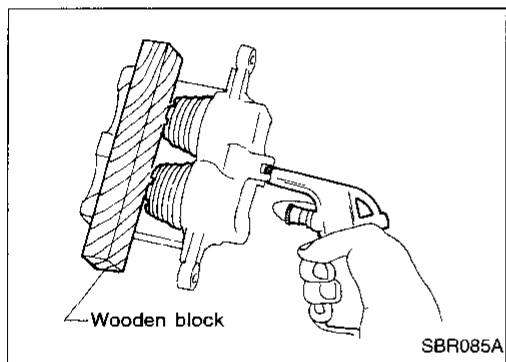

Disassembly

WARNING:

Do not place your fingers in front of piston.

CAUTION:

- Do not scratch or score cylinder wall.
 - CL28VD type front disc brake uses plastic pistons, handle them carefully.
1. Push out piston and dust cover with compressed air. For CL28VD (2-piston type), use a wooden block so that both pistons come out evenly.
 2. Remove piston seal with a suitable tool.

Inspection — Caliper

CYLINDER BODY

- Check inside surface of cylinder for score, rust, wear, damage and presence of foreign objects. If any of the above conditions are observed, replace cylinder body.
- Minor damage from rust or foreign objects may be eliminated by polishing the surface with a fine emery sandpaper. Replace cylinder body if necessary.

CAUTION:

Use brake fluid to clean. Never use mineral oil.

PISTON

— for steel piston (CL28VA) —

Check piston for score, rust, wear, damage and presence of foreign objects. Replace if any of these conditions are observed.

CAUTION:

Piston sliding surface is plated. Do not polish with emery sandpaper even if rust or foreign objects are stuck to sliding surface.

— for plastic piston (CL28VD) —

Check pistons for uneven surface, chips and cracks. Replace if any of these conditions are observed.

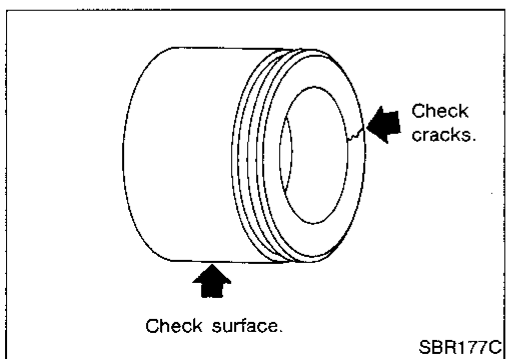

GI

MA

EM

LC

EC

FE

CL

MT

AT

TF

PD

FA

RA

BR

ST

RS

BT

HA

EL

IDX

FRONT DISC BRAKE

Inspection — Caliper (Cont'd) SLIDE PIN, PIN BOLT AND PIN BOOT

Check for wear, cracks and other damage. Replace if any of these conditions are observed.

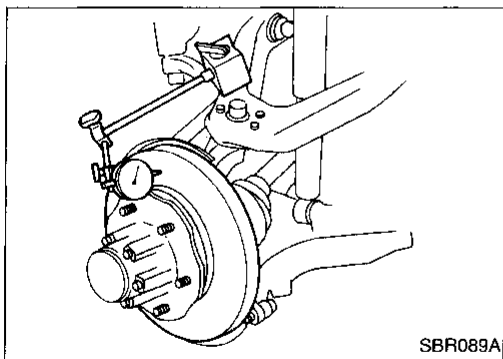

Inspection — Rotor

RUNOUT

1. Check runout using a dial indicator.
 - **Make sure that wheel bearing axial end play is within the specifications before measuring. Refer to FA section ("Front Wheel Bearing", "ON-VEHICLE SERVICE").**

Maximum runout:

0.07 mm (0.0028 in)

2. If the runout is out of specification, machine rotor with on-car brake lathe ("MAD, DL-8700", "AMMCO 700 and 705" or equivalent).

THICKNESS

Thickness variation (At least 8 positions):

Maximum 0.02 mm (0.0008 in)

If thickness variation exceeds the specification, machine rotor with on-car brake lathe.

Rotor repair limit:

CL28VA 20.0 mm (0.787 in)

CL28VD 24.0 mm (0.945 in)

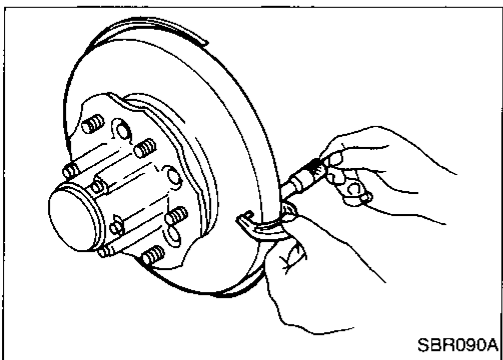

Assembly

1. Insert piston seal into groove on cylinder body.
2. With piston boot fitted to piston, insert piston boot into groove on cylinder body and install piston.
3. Properly secure piston boot.

CAUTION:

- **Secure dust seal properly.**
- **Lubricate with new brake fluid before installing plastic pistons (CL28VD) into cylinder body.**

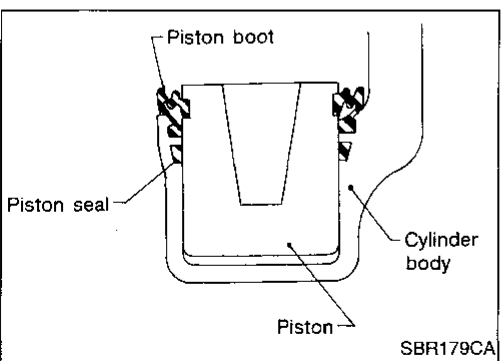
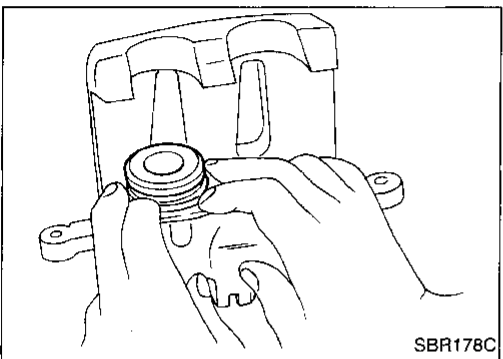

FRONT DISC BRAKE

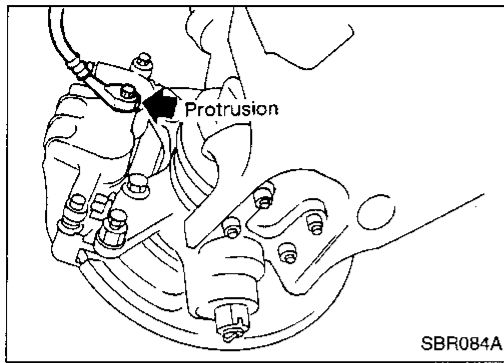

Installation

CAUTION:

- Refill with new brake fluid DOT 3.
 - Never reuse drained brake fluid.
1. Install caliper assembly.
 2. Install brake hose to caliper securely.
 3. Install all parts and secure all bolts.
 4. Bleed air. Refer to "Bleeding Procedure", BR-5.

GI

MA

EM

LC

EC

FE

CL

MT

AT

TF

PD

FA

RA

BR

ST

RS

BT

HA

EL

IDX

REAR DRUM BRAKE

LT30A (4WD)

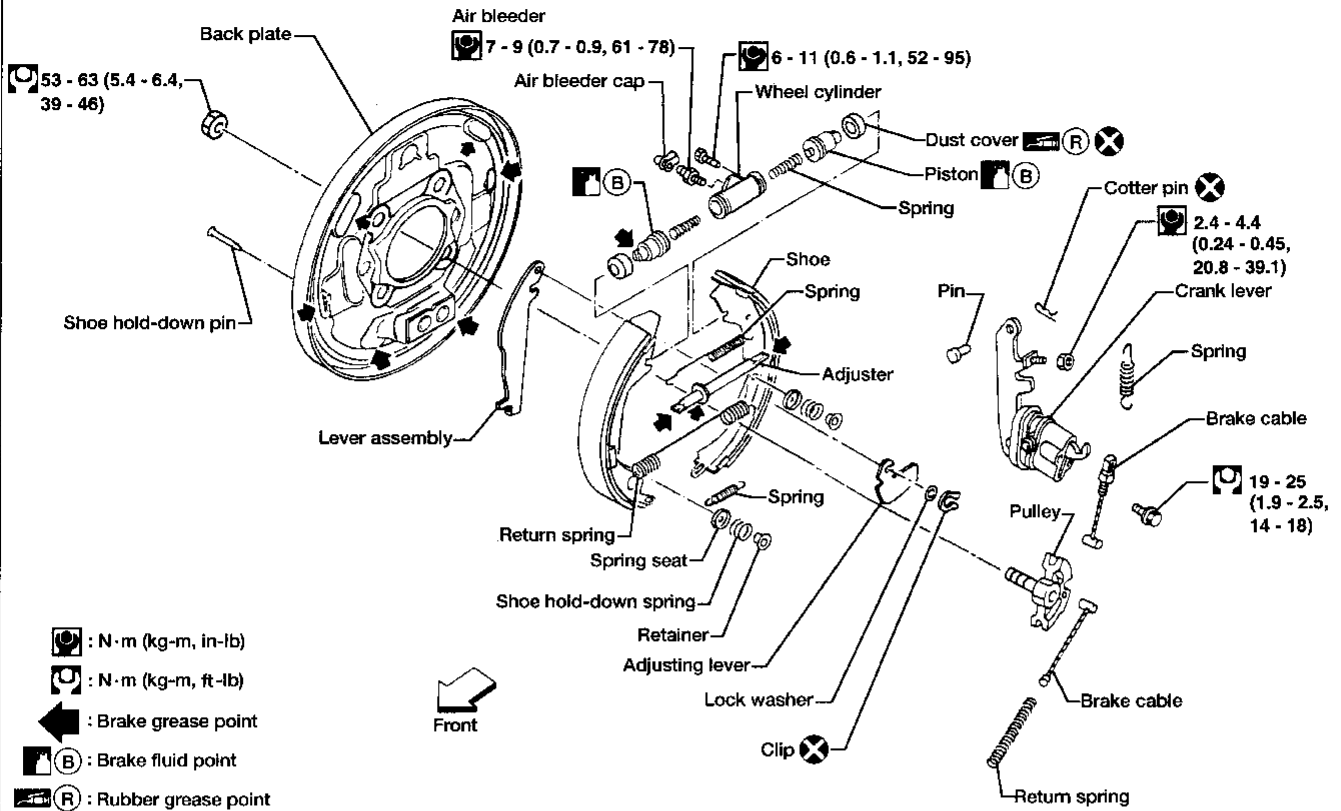

ABR367

LT26B (2WD)

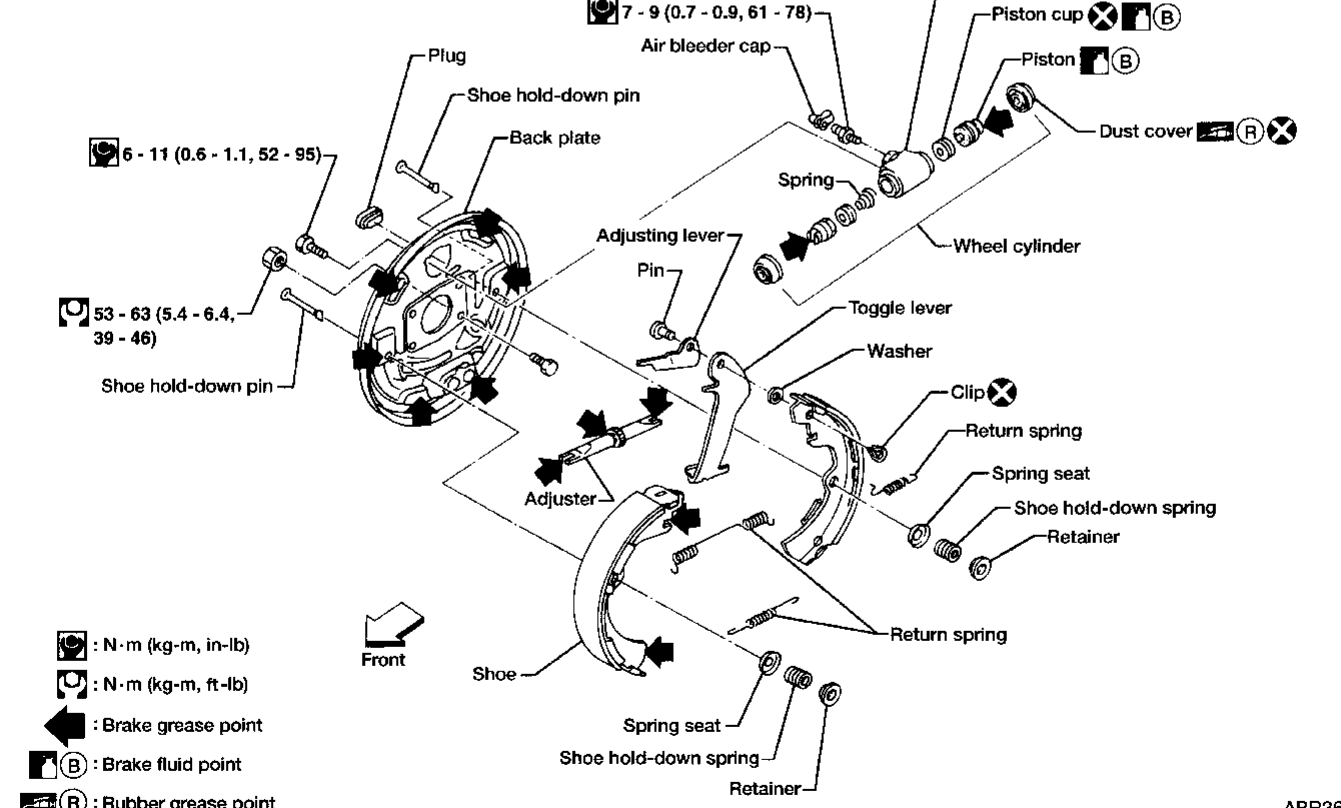

ABR368

REAR DRUM BRAKE

Removal

WARNING:

Clean brake lining with a vacuum dust collector to minimize the hazard of airborne materials.

CAUTION:

Make sure parking brake lever is completely released.

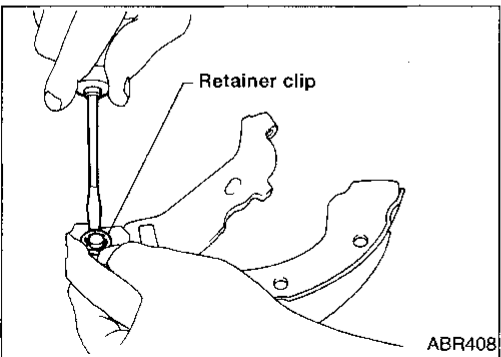
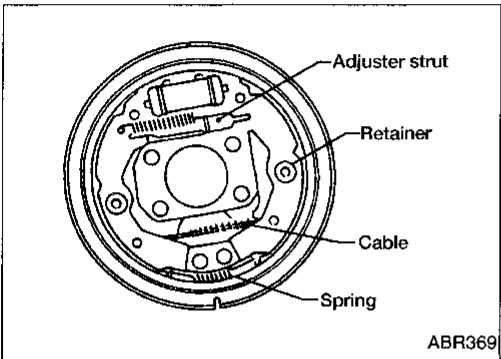
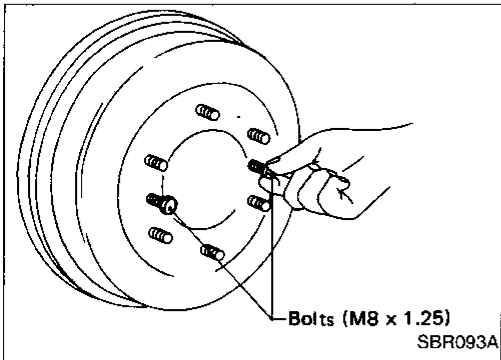
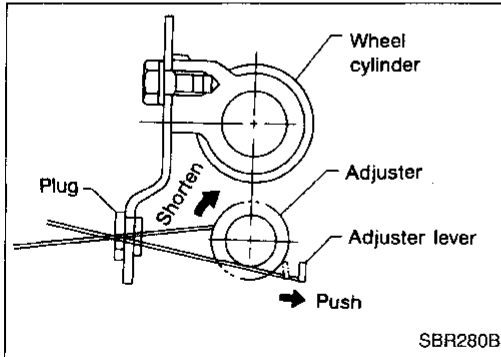

1. Release parking brake lever fully, then remove drum.
 - If drum is hard to remove, the following procedures should be carried out.
 - a. Remove plug. Then shorten adjuster to make clearance between brake shoe and drum.

- b. Install two bolts as shown. Tighten the two bolts gradually.

2. After removing retainer, remove spring by rotating shoes.
 - Be careful not to damage wheel cylinder piston boots.
 - Be careful not to damage parking brake cable when separating it.

3. Remove adjuster.
 4. Disconnect parking brake cable from toggle lever.

5. Remove retainer clip with a suitable tool. Then separate toggle lever and brake shoe.

REAR DRUM BRAKE

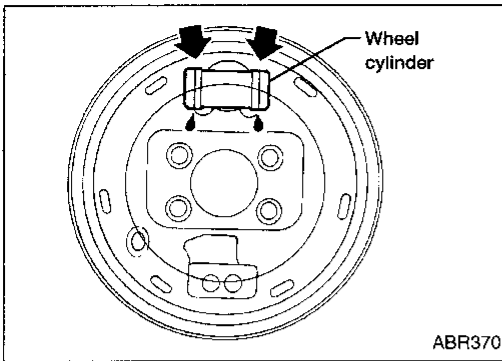

Inspection — Wheel Cylinder

- Check wheel cylinder for leakage.
- Check for wear, damage and loose conditions. Replace if any such conditions exists.

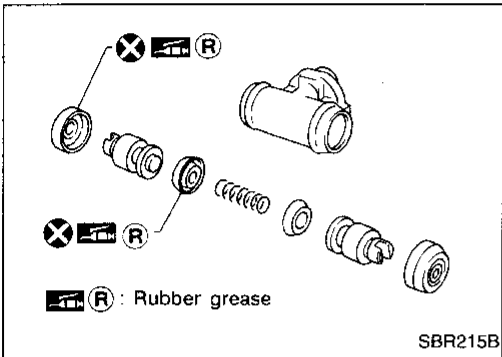

Wheel Cylinder Overhaul

- Check all internal parts for wear, rust and damage. Replace if necessary.
- Pay attention not to scratch cylinder when installing pistons.

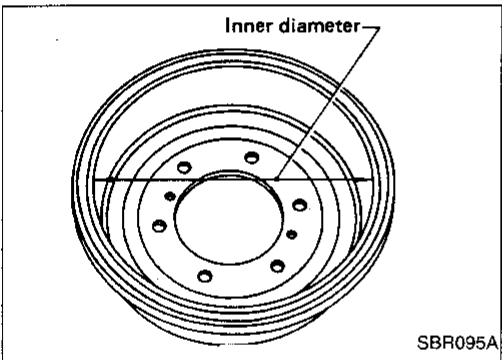

Inspection — Drum

Maximum inner diameter (Repair limit):

LT26B 261.5 mm (10.30 in)

LT30A 296.5 mm (11.67 in)

- Contact surface should be finished with No. 120 to 150 emery sandpaper.
- Using a brake lathe, machine brake drum if it shows score marks, partial wear or stepped wear.
- After brake drum has been completely reconditioned or replaced, check drum and shoes for proper contact pattern.

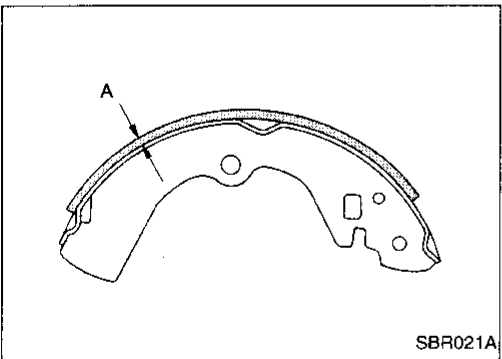

Inspection — Lining

Check lining thickness.

Standard lining thickness:

LT26B 5.5 mm (0.217 in)

LT30A 6.1 mm (0.240 in)

Lining wear limit (A):

LT26B 1.5 mm (0.059 in)

LT30A 1.5 mm (0.059 in)

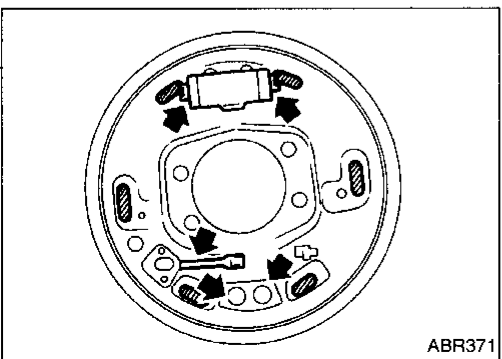

Installation

- **Always perform shoe clearance adjustment. Refer to BR-29.**
1. Fit toggle lever to brake shoe with retainer clip.
 2. Apply brake grease to the contact areas shown at left.

REAR DRUM BRAKE

Installation (Cont'd)

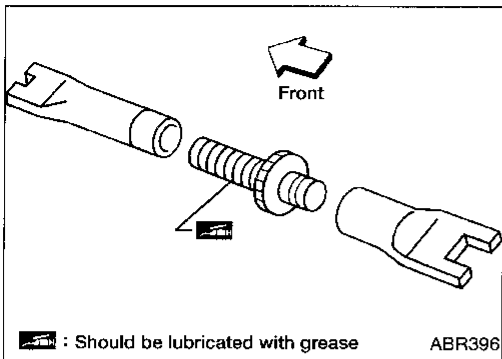

3. Shorten adjuster by rotating it.
- Pay attention to direction of adjuster.

Wheel	Screw
Left	Left-hand thread
Right	Right-hand thread

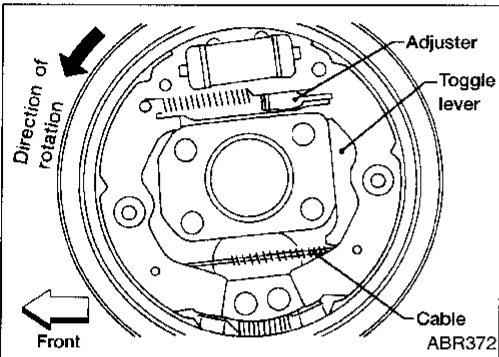

4. Connect parking brake cable to toggle lever.
5. Install all parts.
- Be careful not to damage wheel cylinder piston boots.
6. Check that all parts are installed properly.
- After installation is completed, adjust shoe-to-drum clearance.
7. Install brake drum.
8. When installing new wheel cylinder or overhauling wheel cylinder, bleed air. Refer to "Bleeding Procedure", BR-5.
9. Adjust parking brake. Refer to BR-29.
- Install all the parts by referring to the figure below.

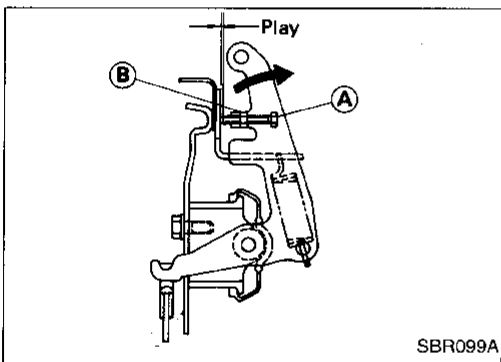

LT30A model

- After installing crank lever on back plate, make sure that there is no play between crank lever and back plate. If play exists, adjust bolt (A) and lock nut (B).

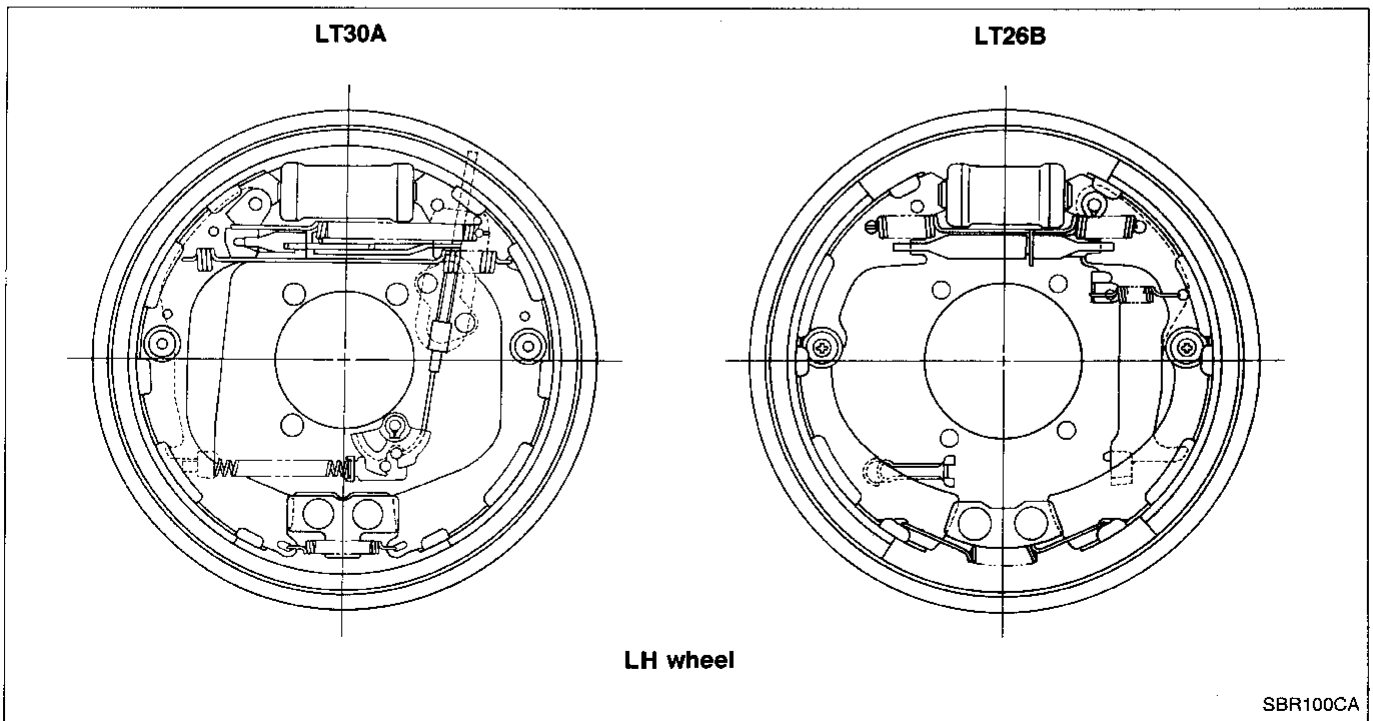

GI
MA
EM
LC
EC
FE
CL
MT
AT
TF
PD
FA
RA
BR
ST
RS
BT
HA
EL
IDX

PARKING BRAKE CONTROL

2WD

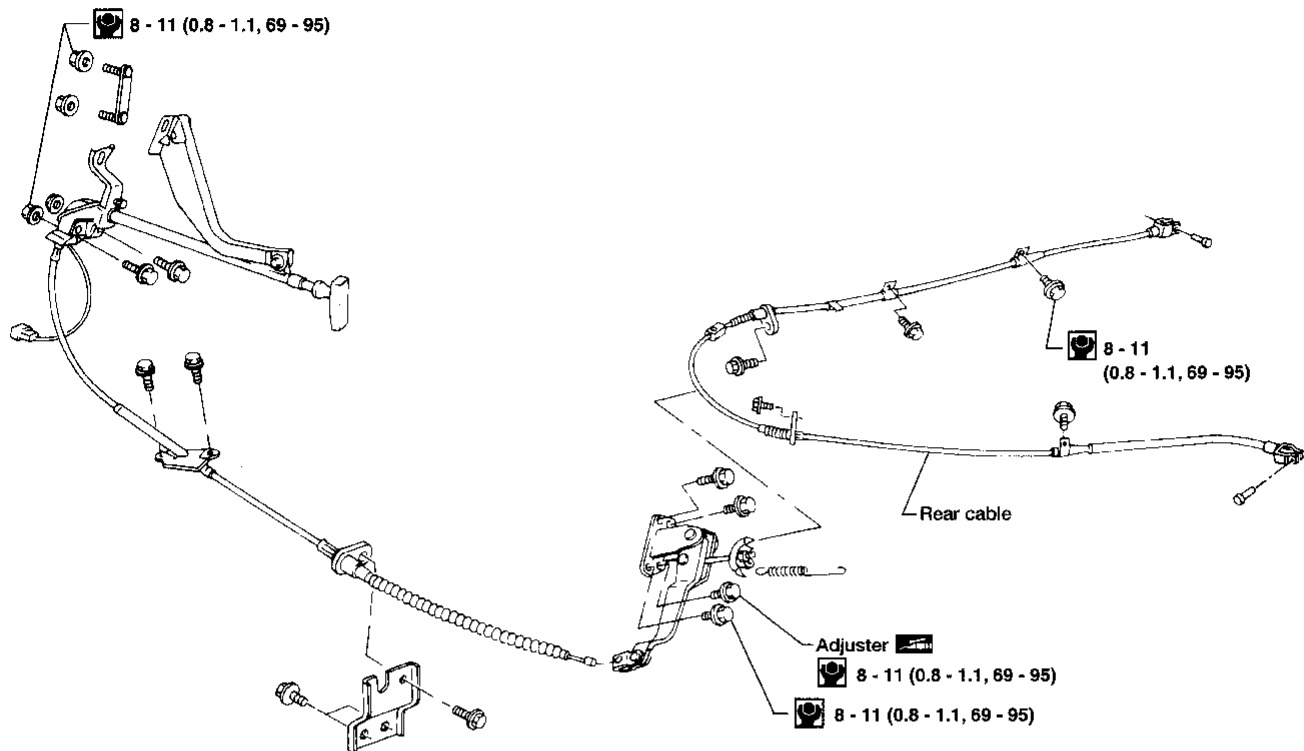

4WD

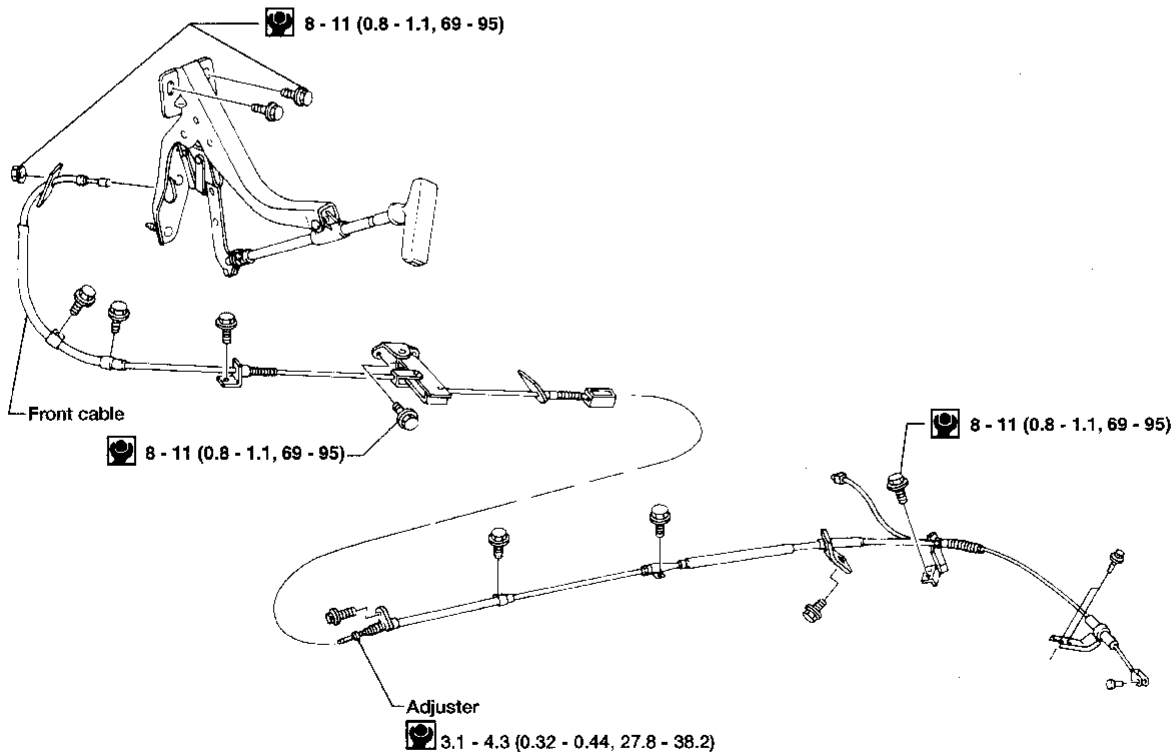

: N · m (kg-m, in-lb)

ABR411

Removal and Installation

- Be careful not to damage cable.
- Make sure there is no free play after installation.

Inspection

1. Check control lever for wear and damage. Replace if necessary.
2. Check wires for discontinuity and deterioration. Replace if necessary.
3. Check warning lamp and switch. Correct if necessary.
4. Check part at each connecting portion and, if found deformed or damaged, replace.

Adjustment

Adjust parking brake as follows:

— LT26B —

1. Pull parking brake lever several times until clicking sound does not occur from rear brakes.
2. Release parking brake lever.
3. Loosen lock nut (A), rotate adjusting nut (B).
4. Tighten lock nut (A).
5. Pull control lever with specified amount of force. Check lever stroke and ensure smooth operation.

Number of notches: Refer to SDS, BR-51

— LT30A —

1. Release parking brake lever.
2. Depress brake pedal fully at least 10 times.
3. Loosen lock nut (A), rotate adjuster (B).
4. Tighten lock nut (A).
5. Pull control lever with specified amount of force. Check lever stroke and ensure smooth operation.

Number of notches: Refer to SDS, BR-51.

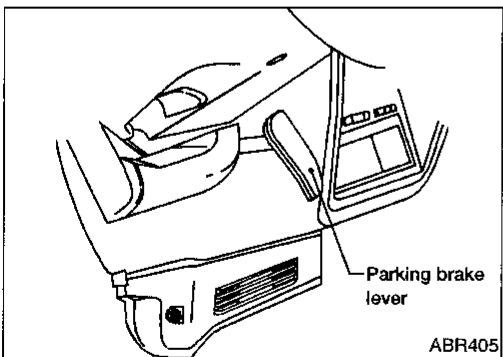
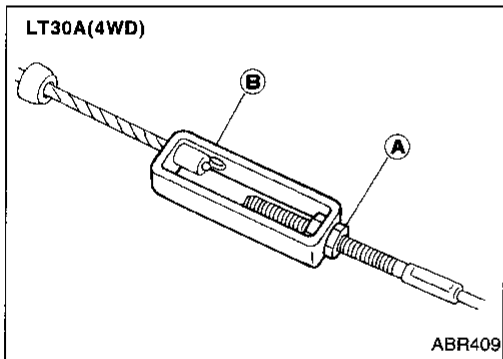
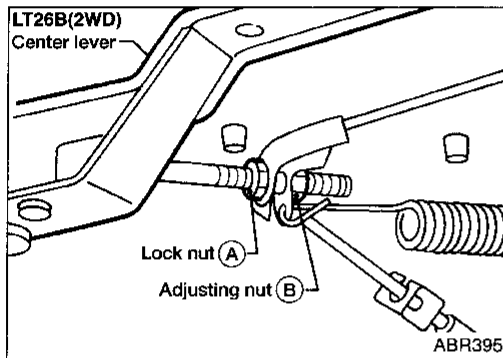

REAR WHEEL ANTI-LOCK BRAKE SYSTEM

Purpose

The Rear Wheel Anti-Lock Brake System (ABS) consists of electronic and hydraulic components. It controls rear braking force so locking of the rear wheels can be avoided.

The ABS:

- 1) Improves proper tracking performance during severe braking.
- 2) Eases obstacle avoidance during severe braking.
- 3) Improves vehicle stability.

Operation

- When the vehicle speed is less than 10 km/h (6 MPH) this system does not work.
- The Rear Wheel Anti-Lock Brake System (ABS) has self-test capabilities. The system turns on the ABS warning lamp for a few seconds each time the ignition switch is turned ON. After the engine is started, the ABS warning lamp turns off. The system performs a circuit check when the ignition switch is first turned ON. If a malfunction is found during this check, the ABS warning lamp will stay on.
- While driving, a mechanical noise may be heard and slight pedal pulsation may be felt during ABS operation. This is a normal condition.

CAUTION:

When driving in 4WD, the rear wheel anti-lock brake system is not effective in most cases. The rear wheels will lock if the front wheels lock because the transfer mechanically couples the front and rear axles together. If this happens, the rear wheel anti-lock brake system may not function but the ordinary brakes will operate normally. The ABS warning lamp will then turn on. The above condition is not a malfunction and the rear wheel anti-lock brake system can be re-activated by starting the engine again. The ABS warning lamp will then go off.

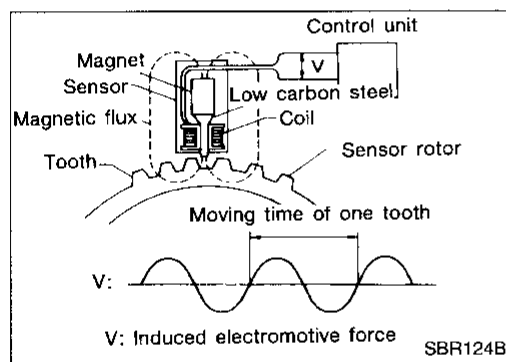

System Description

REAR SENSOR

The rear sensor unit consists of a gear-shaped sensor rotor and a sensor unit. The sensor unit consists of a bar magnet around which a coil is wound. The sensor rotor is installed on the companion flange and the sensor unit is installed on the rear axle housing. A sine-wave current is generated by the rear sensor unit as the rear axle pinion rotates. The frequency and voltage increase as the rotating speed increases.

ABS CONTROL UNIT

The ABS control unit computes the rear axle pinion rotating speed by reading the signal from the rear sensor unit. Then it supplies a DC current to the ABS actuator. If any electrical malfunction is detected in the system, the ABS control unit causes the ABS warning lamp to turn on. In this condition, the ABS system will be deactivated by the ABS control unit, and the vehicle's brake system reverts to normal operation.

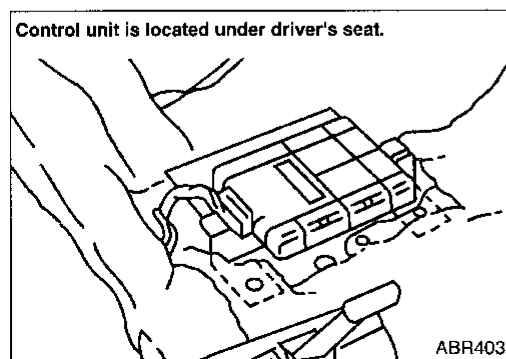
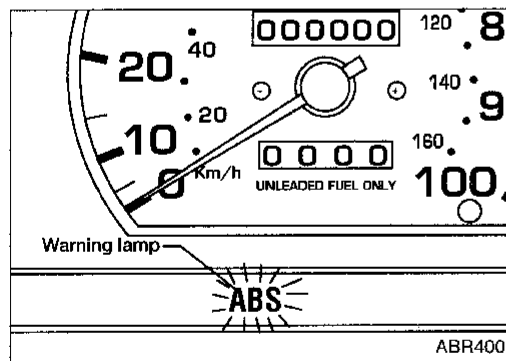

REAR WHEEL ANTI-LOCK BRAKE SYSTEM

System Components

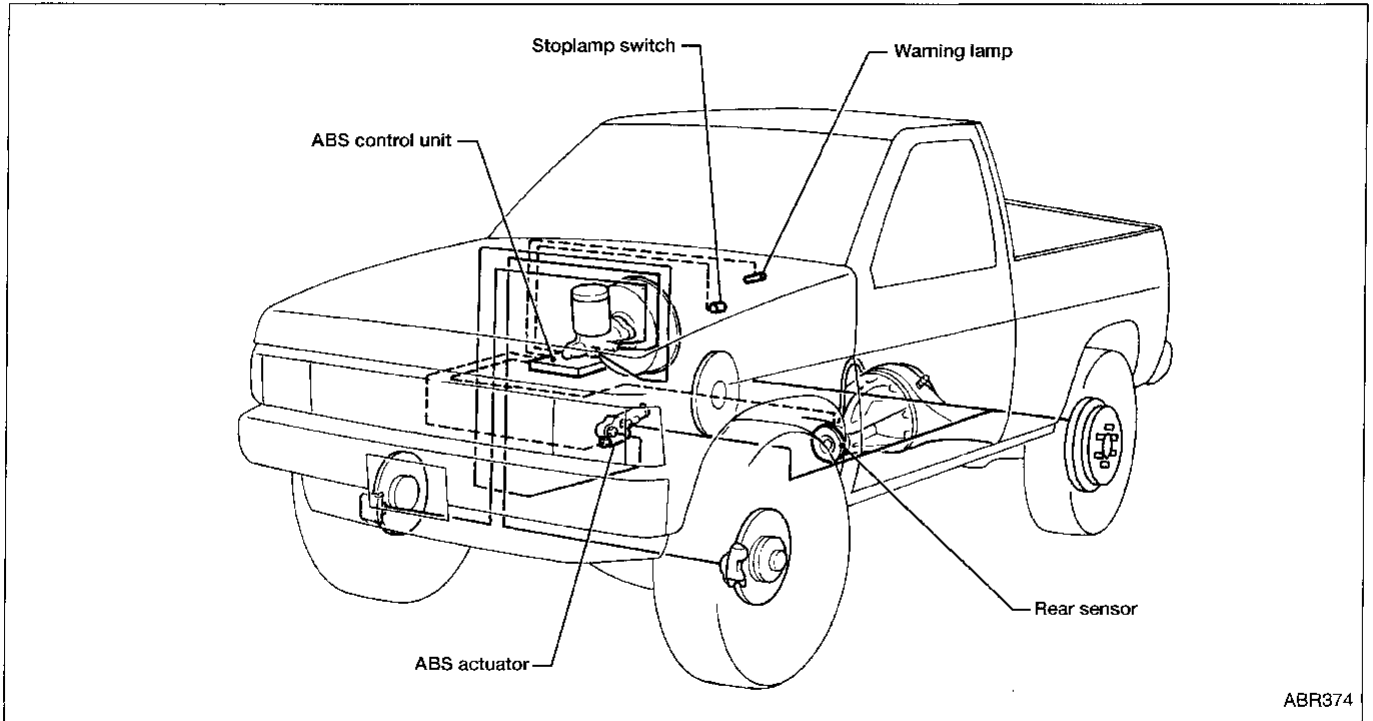

Hydraulic Circuit

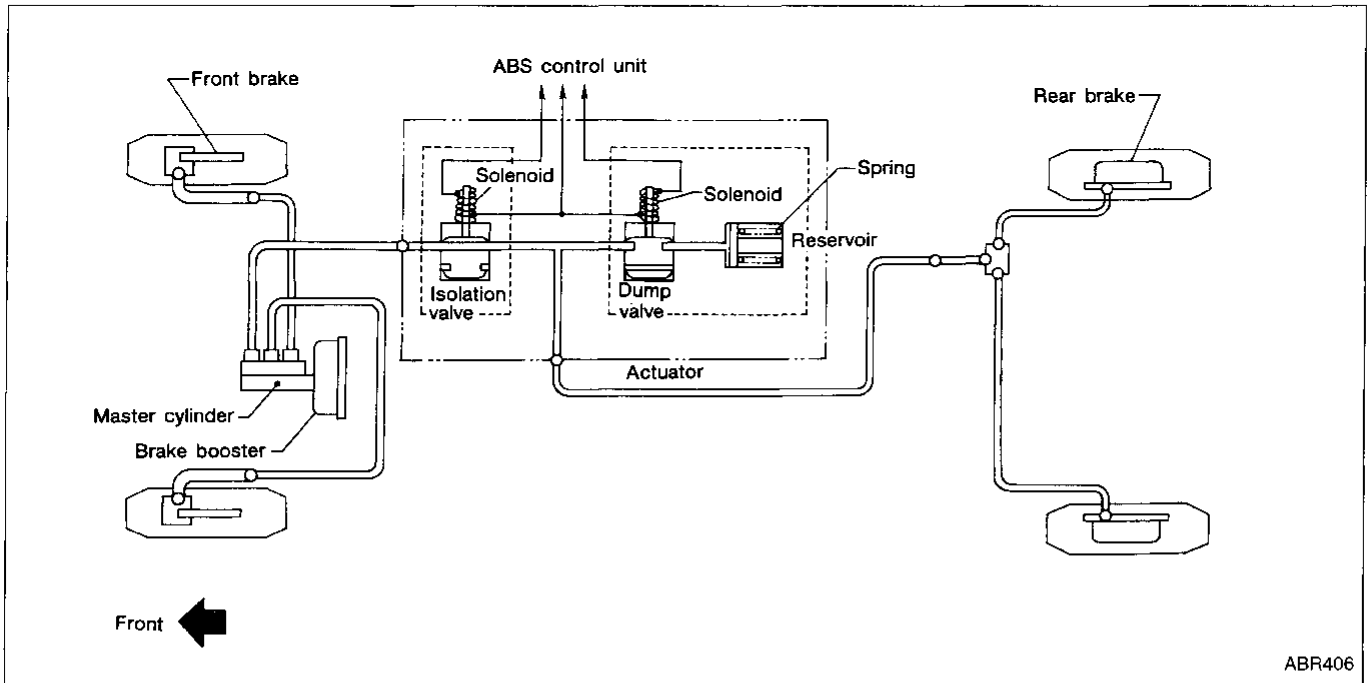

GI
MA
EM
LC
EC
FE
CL
MT
AT
TF
PD
FA
RA
BR
ST
RS
BT
HA
EL
IDX

REAR WHEEL ANTI-LOCK BRAKE SYSTEM

Removal and Installation

CAUTION:

Be careful not to damage sensor edge and sensor rotor teeth. In case the final drive assembly needs to be removed, disconnect the ABS sensor from the assembly and move it away. Failure to do so may result in damage to the sensor wires making the sensor inoperative.

REAR SENSOR AND CONTROL UNIT

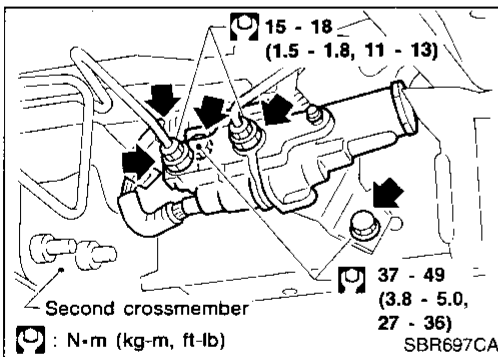
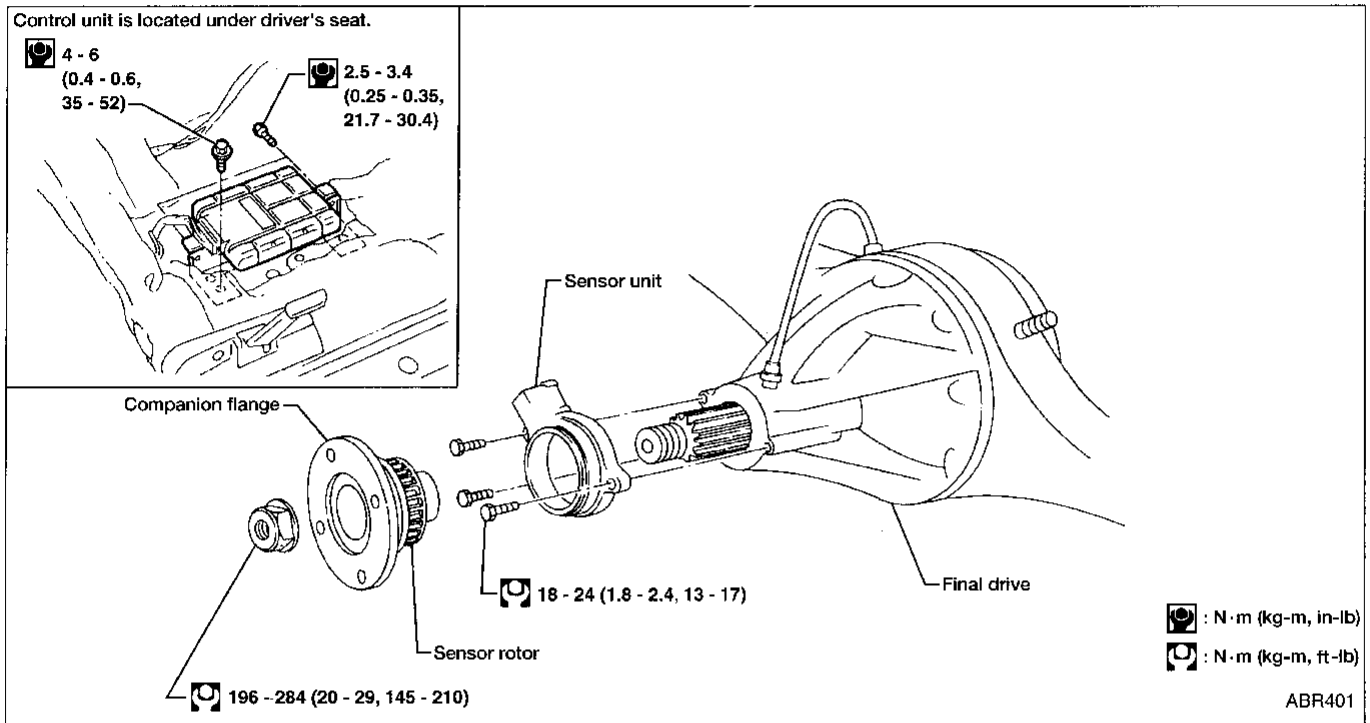

ACTUATOR

Removal

1. Disconnect battery cable.
2. Drain brake fluid.
Refer to "Changing Brake Fluid", "CHECK AND ADJUSTMENT", BR-4.
3. Disconnect connectors, brake pipes and remove fixing nuts.

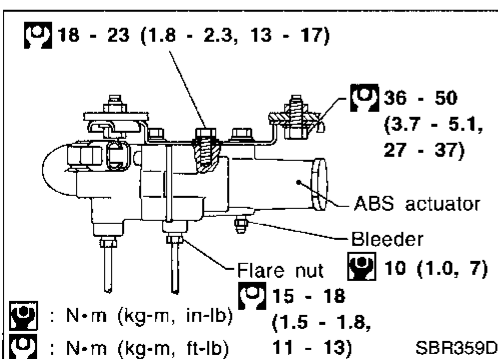

Installation

CAUTION:

After installation, refill brake fluid. Then bleed air. Refer to "Bleeding Procedure", BR-5.

1. Connect brake pipes temporarily.
2. Secure fixing bolts.
3. Torque brake pipe flare nuts.
4. Connect connectors and battery cable.

TROUBLE DIAGNOSES

How to Perform Trouble Diagnoses for Quick and Accurate Repair

WORK FLOW

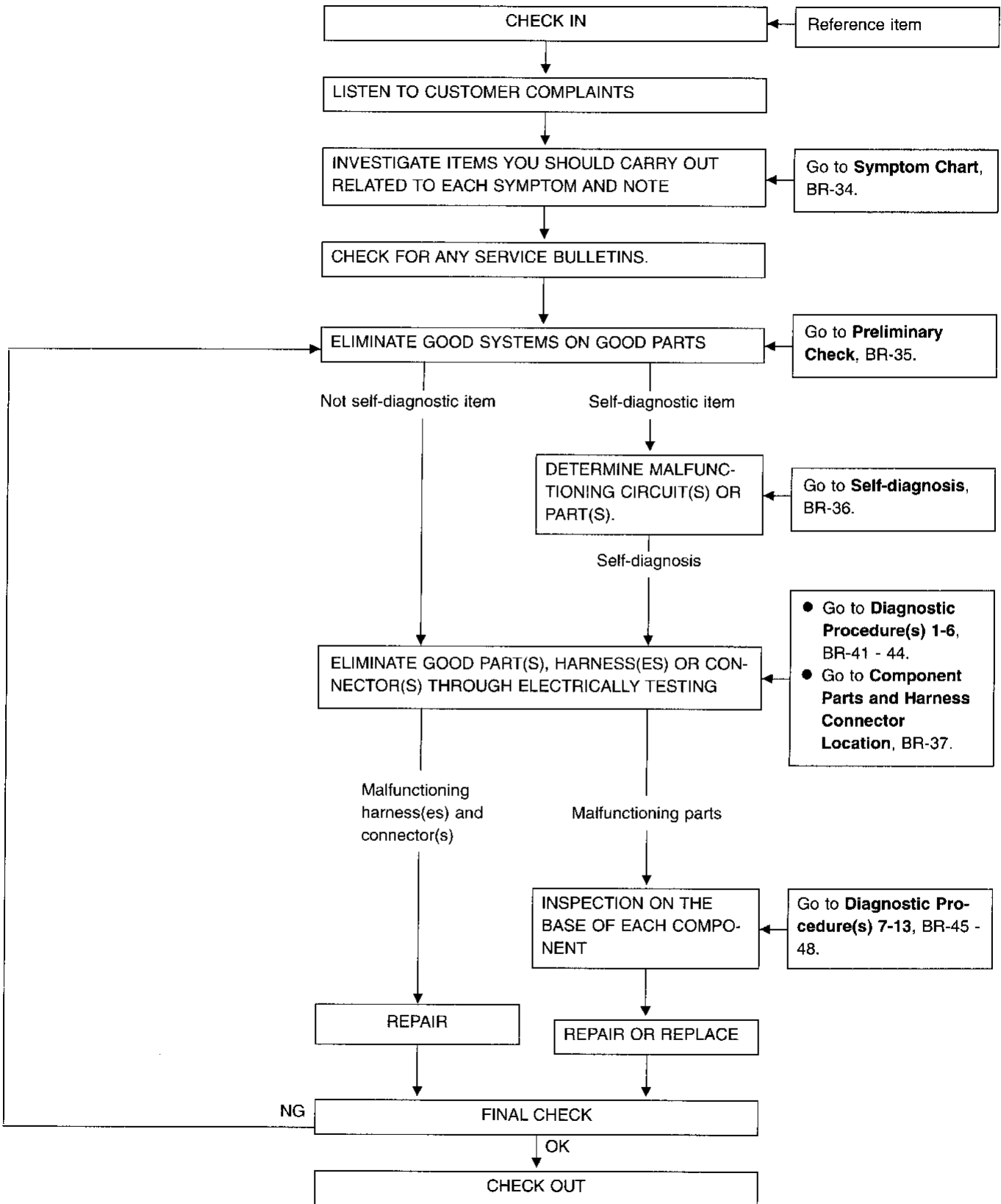

GI
MA
EM
LC
EC
FE
CL
MT
AT
TF
PD
FA
RA
BR
ST
RS
BT
HA
EL
IDX

GI
 MA
 EM
 LC
 EC
 FE
 CL
 MT
 AT
 TF
 PD
 FA
 RA
BR
 ST
 RS
 BT
 HA
 EL
 IDX

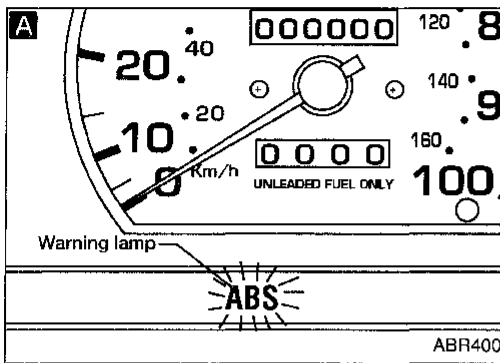

Preliminary Check 1

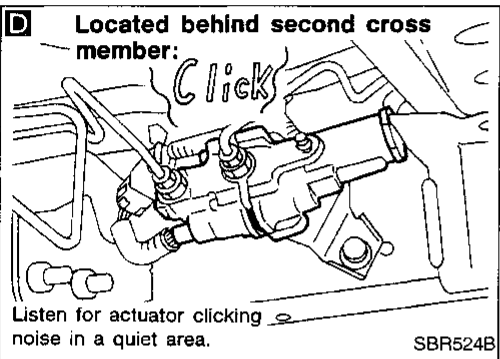
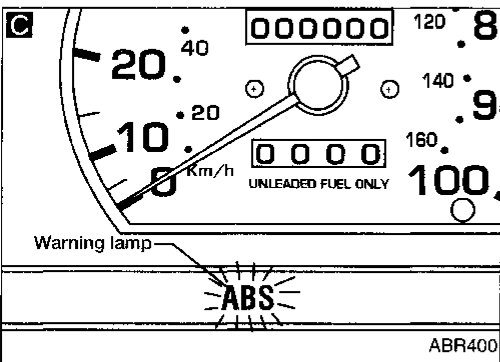
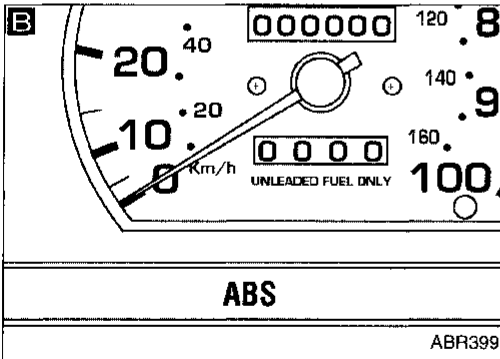
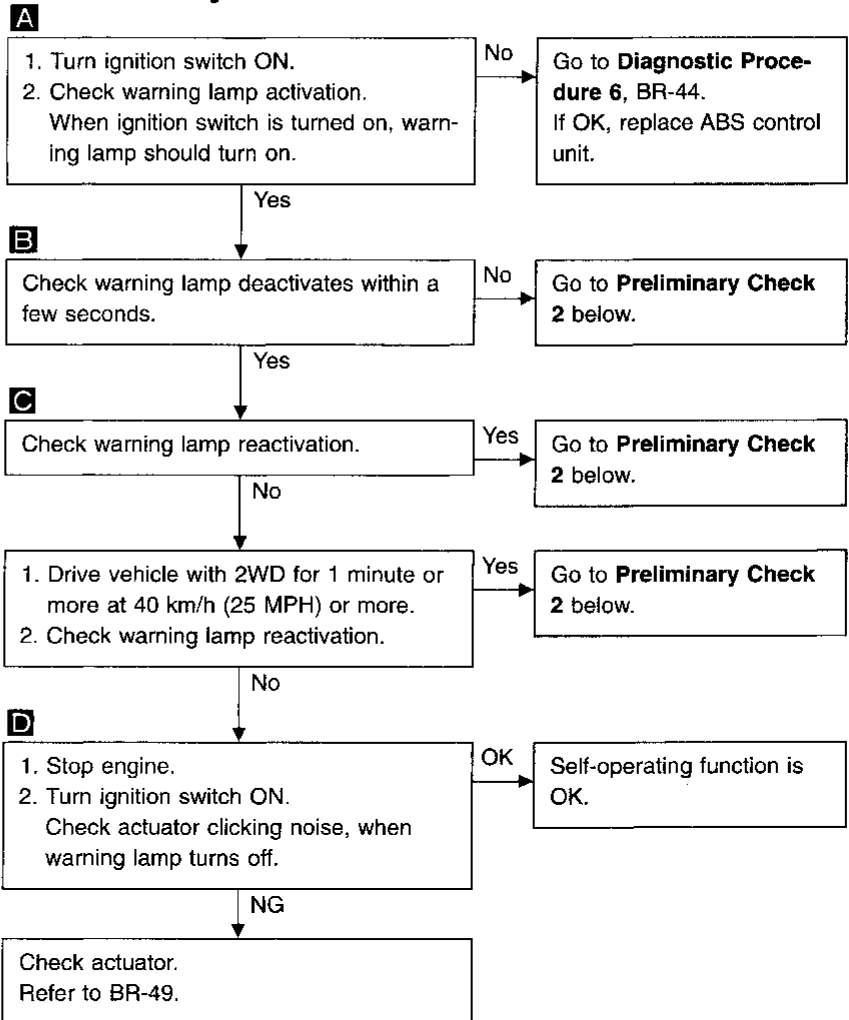

Preliminary Check 2

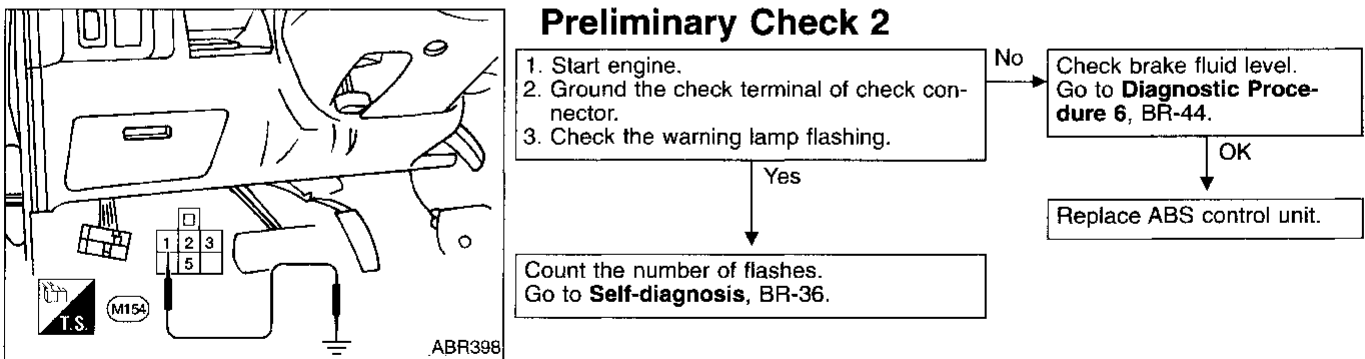

TROUBLE DIAGNOSES

Self-diagnosis

CHECKING THE NUMBER OF WARNING LAMP FLASHES

When a problem occurs in the ABS, the ABS warning lamp on the instrument panel turns on. As shown in the table, the control unit performs self-diagnosis.

To obtain satisfactory self-diagnosing results, the vehicle must be driven in 2WD above 40 km/h (25 MPH) for at least one minute before the self-diagnosis is performed. After the vehicle has been stopped, the number of ABS warning lamp flashes is counted by grounding the check terminal, with the engine running, thereby identifying a malfunctioning part or unit by the number of flashes.

If more than two parts or units malfunction at the same time, the ABS warning lamp will flash to indicate one of the malfunctioning parts or units. After the part or unit has been repaired, the ABS warning lamp will then flash to indicate that the other part or unit is malfunctioning.

No. of warning lamp flashes	Detected items	Malfunctioning cause or part		Diagnostic Procedure
2	ABS actuator	ISO solenoid	Open	Diagnostic Procedure 7
7			Short circuit	Diagnostic Procedure 7
4			Blocked	Diagnostic Procedure 8
3		DUMP solenoid	Open	Diagnostic Procedure 9
8			Short circuit	Diagnostic Procedure 9
9		Rear sensor	Open	
10	Short circuit		Diagnostic Procedure 10	
6	Erratic		Diagnostic Procedure 11	
13, 14 or 15	ABS control unit	—		Diagnostic Procedure 12
5	Other			Diagnostic Procedure 13

CAUTION:

When driving in 4WD, the rear wheel anti-lock brake system is not effective in most cases. The rear wheels will lock if the front wheels lock because the transfer mechanically couples the front and rear axles together. If this happens, the rear wheel anti-lock brake system may not function but the ordinary brakes will operate normally. The ABS warning lamp will then turn on. The above condition is not a malfunction and the rear wheel anti-lock brake system can be re-activated by starting the engine again. The ABS warning lamp will then go off.

Component Parts and Harness Connector Location

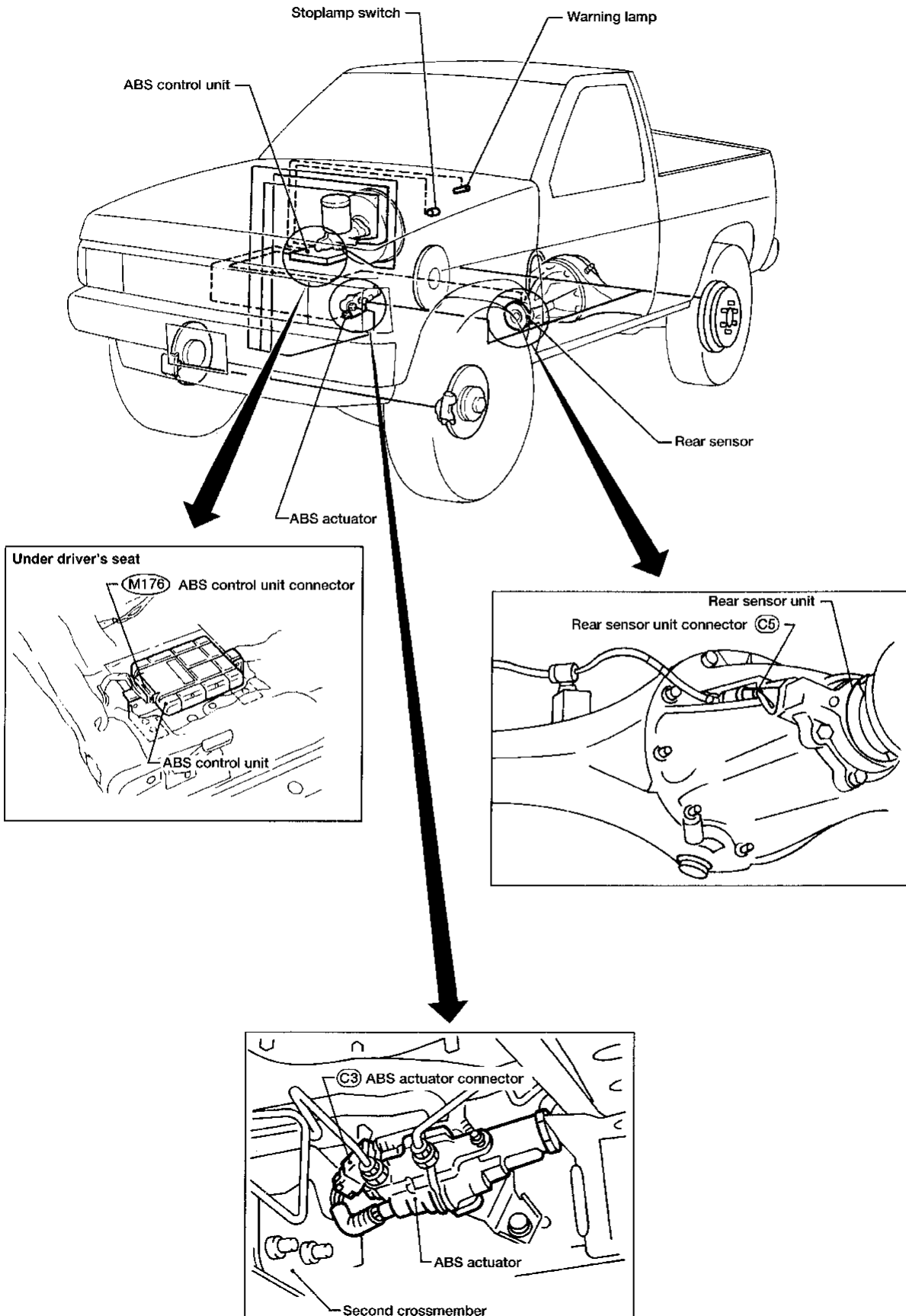

GI
MA
EM
LC
EC
FE
CL
MT
AT
TF
PD
FA
RA
BR
ST
RS
BT
HA
EL
IDX

TROUBLE DIAGNOSES

Wiring Diagram -ABS-

BR-ABS-01

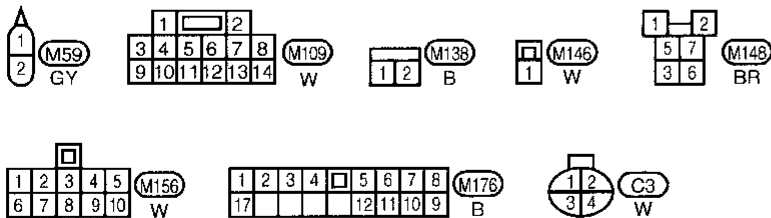
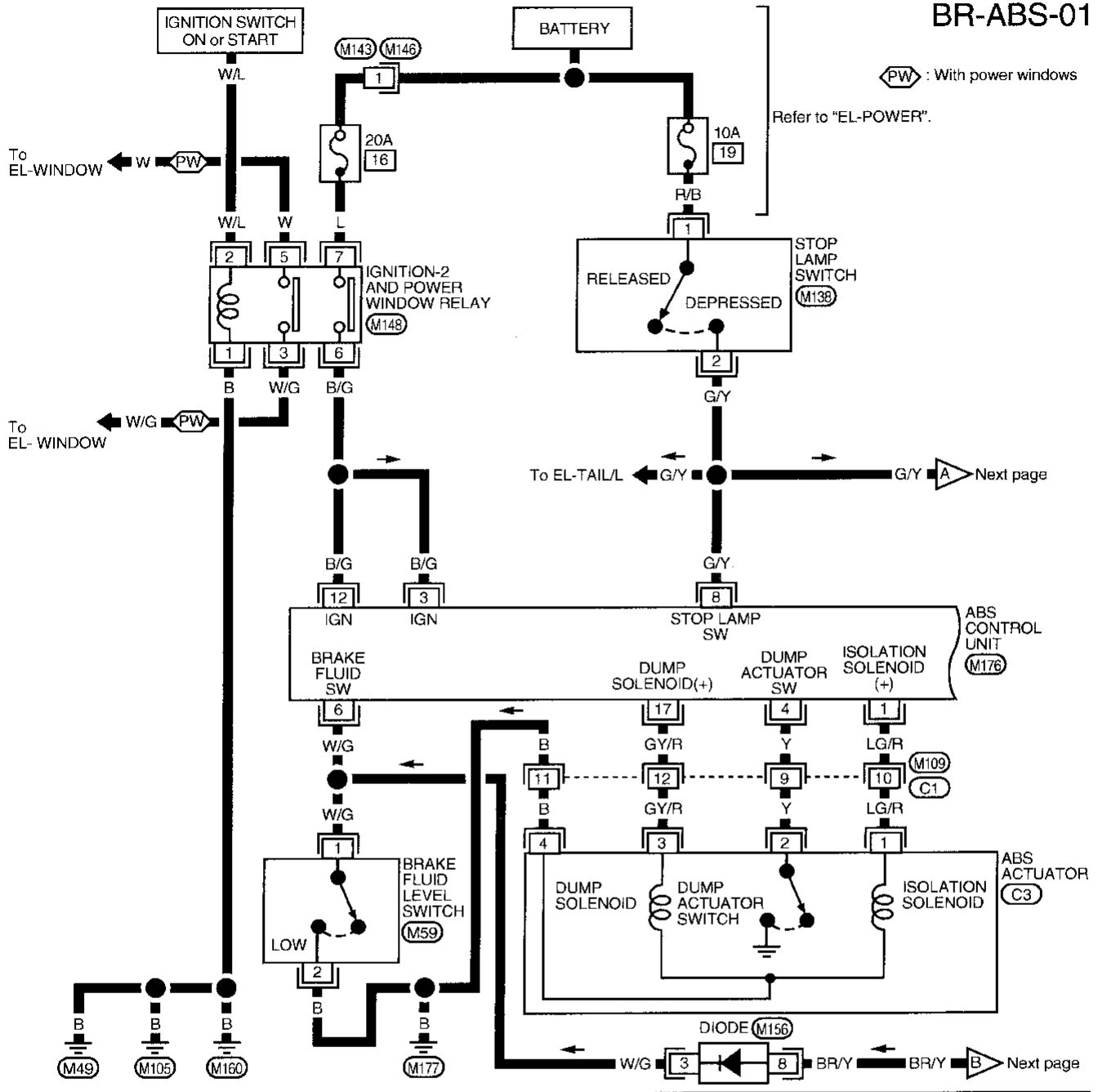

CF
MA
EM
LC
EC
FE
CL
MT
AT
TF
PD
FA
RA
BR
ST
RS
BT
HA
EL
IDX

TROUBLE DIAGNOSES

Wiring Diagram - ABS- (Cont'd)

BR-ABS-02

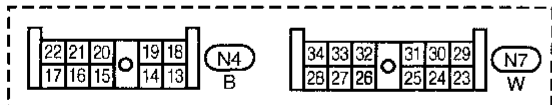
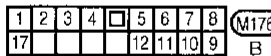
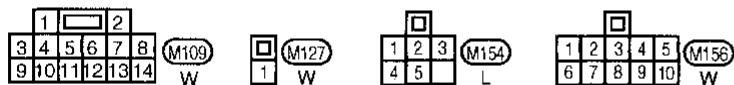
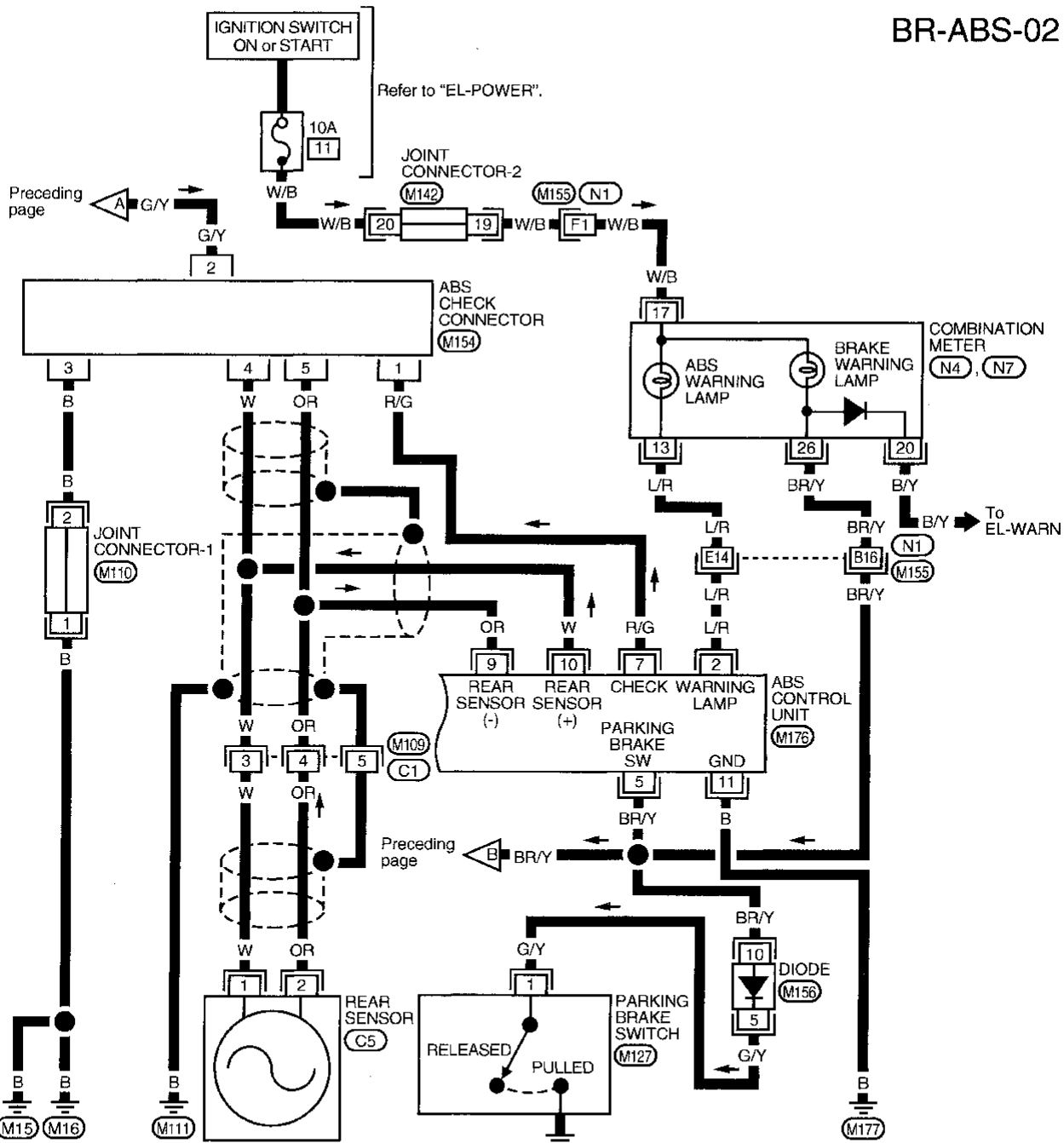

Refer to last page (Foldout page).

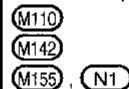

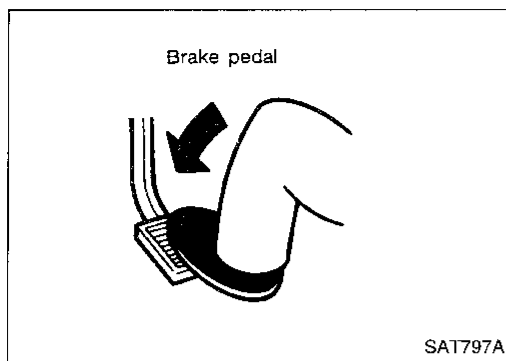

Diagnostic Procedure 1

SYMPTOM: Pedal vibration or noise

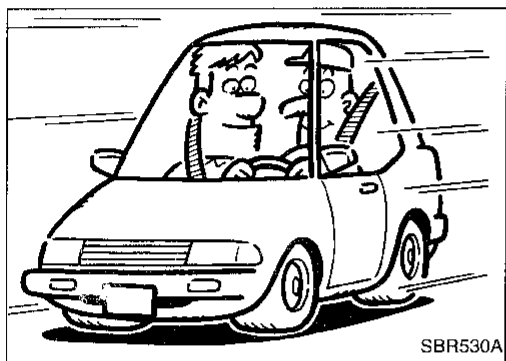
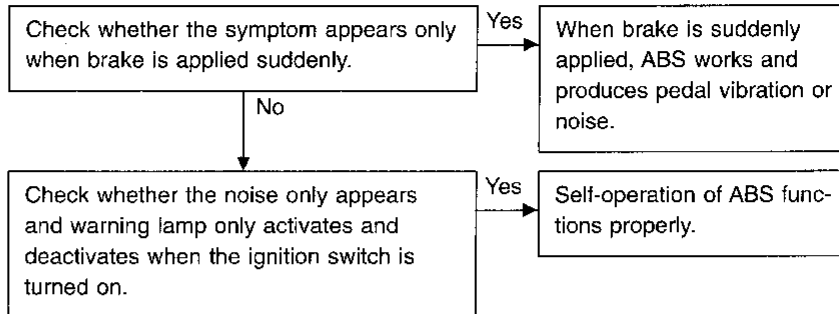

Diagnostic Procedure 2

SYMPTOM: Long stopping distance
Refer to worksheet results.

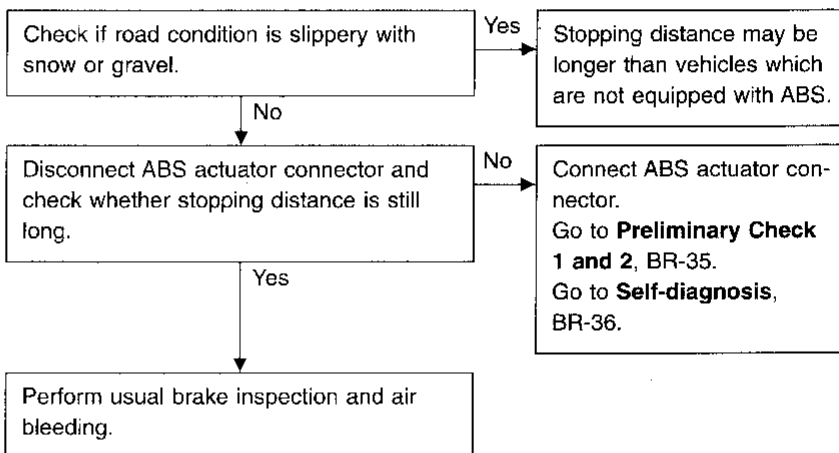

Diagnostic Procedure 3

SYMPTOM: Brake pedal stroke is large.

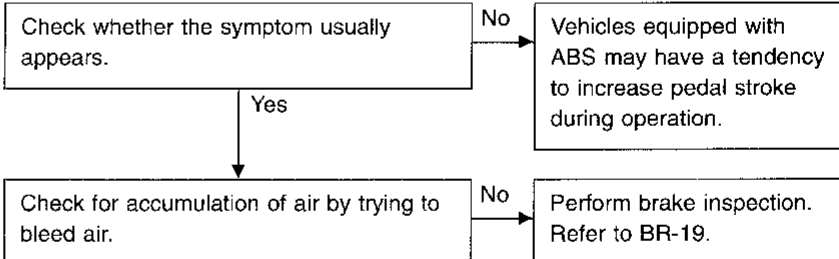
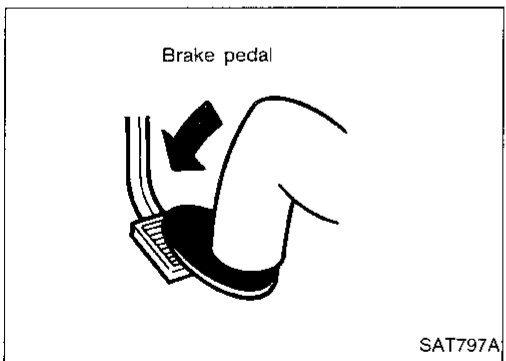

GI
 MA
 EM
 LC
 EC
 FE
 CL
 MT
 AT
 TF
 PD
 FA
 RA
 ST
 RS
 BT
 HA
 EL
 IDX

BR

Diagnostic Procedure 4

SYMPTOM: ABS does not work.

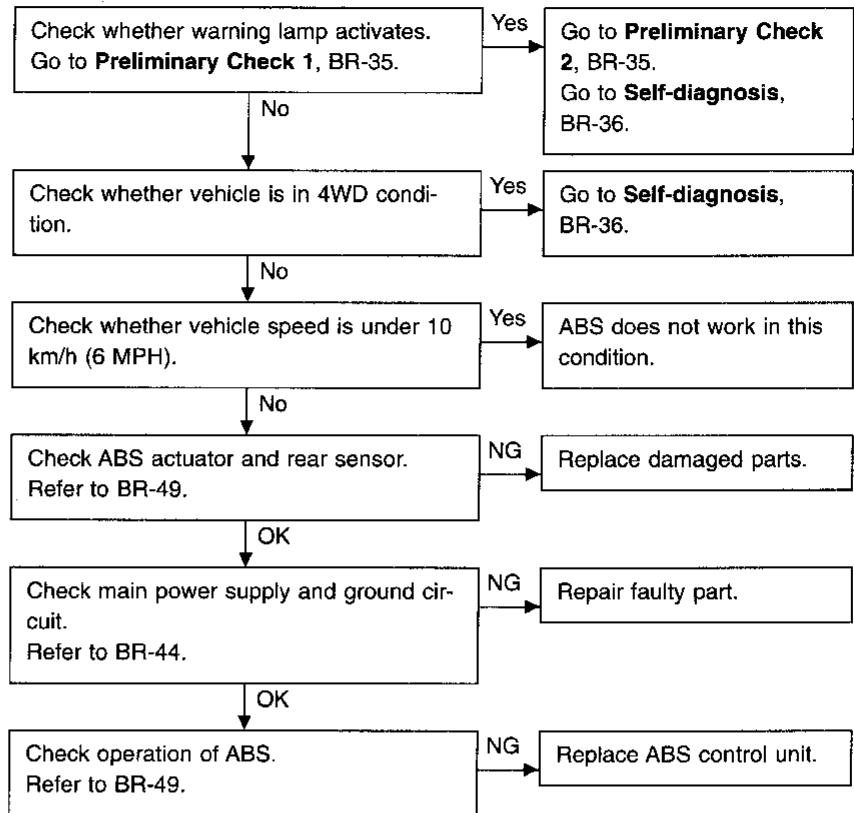

TROUBLE DIAGNOSES

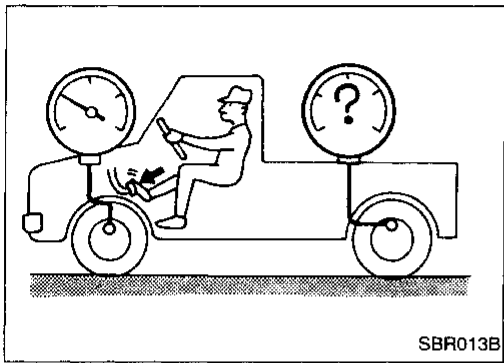

Diagnostic Procedure 5

SYMPTOM: ABS works frequently.

CHECK BRAKE FLUID PRESSURE.

Check whether brake fluid pressure distribution is normal.
Refer to BR-8 or BR-10.

NG

Replace master cylinder.

OK

Perform usual brake inspection.

NG

Repair.

OK

When wheel lock occurs frequently due to hard braking operation, the ABS operates at each occurrence of wheel lock. Accordingly, frequent ABS operation is normal under severe braking conditions where wheel lock would occur frequently due to braking.

GI

MA

EM

LC

EC

FE

CL

MT

AT

TF

PD

FA

RA

BR

ST

RS

BT

HA

EL

IDX

Diagnostic Procedure 6

MAIN POWER SUPPLY AND GROUND CIRCUIT (Not self-diagnostic item)

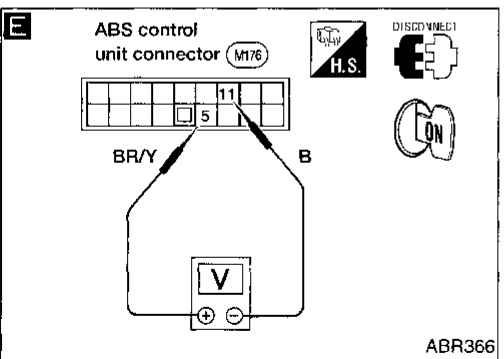
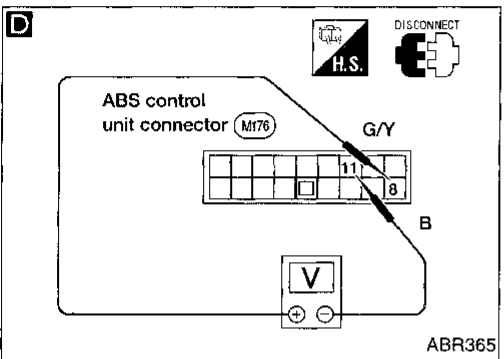
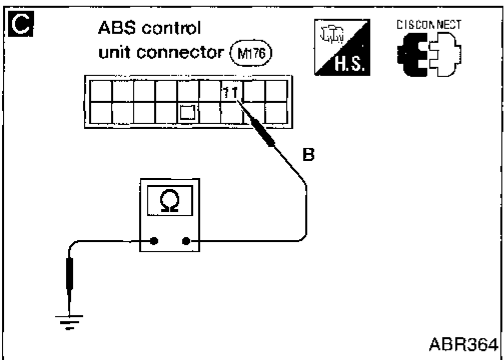
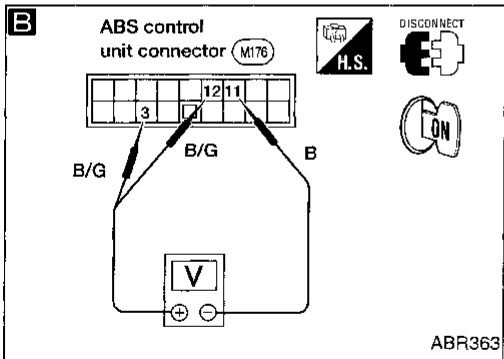
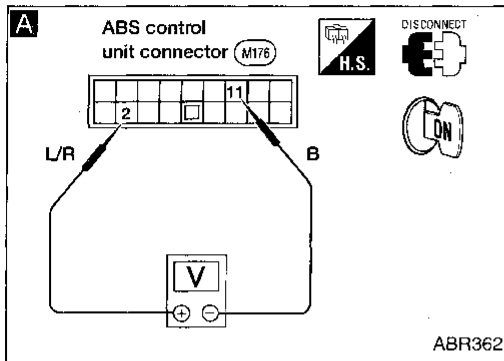

A

CHECK WARNING LAMP POWER SUPPLY.

1. Connect battery cable and confirm battery voltage is 12V.
2. Disconnect ABS control unit connector.
3. Turn ignition switch ON.
4. Do approx. 12 volts exist between ABS control unit connector terminals ② and ⑪?

C

CHECK GROUND CIRCUIT.

Check harness continuity, between ABS control unit terminal ⑪ and suitable body ground.

Continuity should exist.

OK →

NG → Repair harness or connectors.

Check and replace fuse, warning lamp or relays if necessary. Repair ignition harness, relay and warning lamp connectors.

B

CHECK ABS RELAY POWER SUPPLY.

1. Turn ignition switch ON.
2. Do approx. 12 volts exist between ABS control unit connector terminals ⑫, ③ and ⑪?

No → Check and replace fuse, ABS relay, or repair harness and connectors.

D

CHECK STOP LAMP SWITCH POWER SUPPLY.

1. Depress brake pedal.
2. Do approx. 12 volts exist between ABS control unit connector terminals ⑧ and ⑪?

No → Adjust stop lamp switch if necessary. Replace stop lamp switch, if necessary or repair harness or connectors.

E

CHECK PARKING BRAKE POWER SUPPLY.

1. Confirm that brake fluid level is adequate. If necessary, refill it.
2. Turn ignition switch ON.
3. Do approx. 12 volts exist between ABS control unit connector terminals ⑤ and ⑪ without parking brake applied? Do approx. 0 volts exist with parking brake applied?

No → Adjust parking brake switch, if necessary. Replace parking brake switch, if necessary or repair harness or connector.

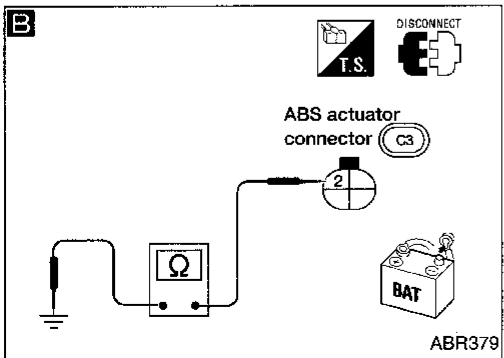
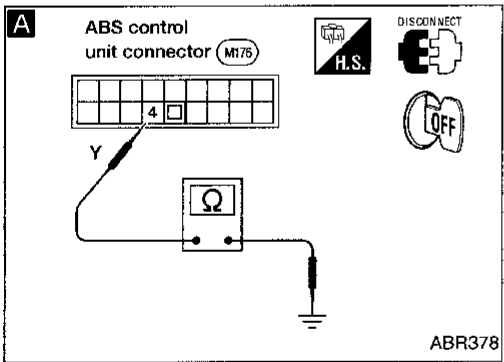
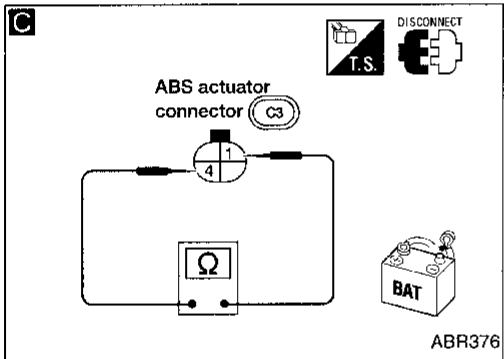
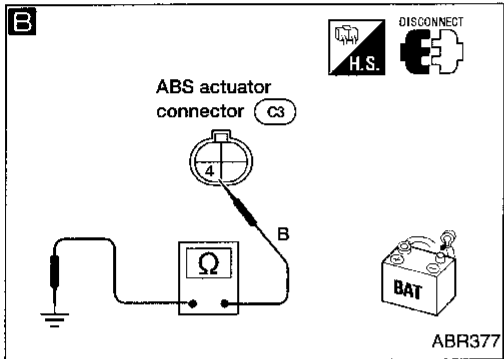
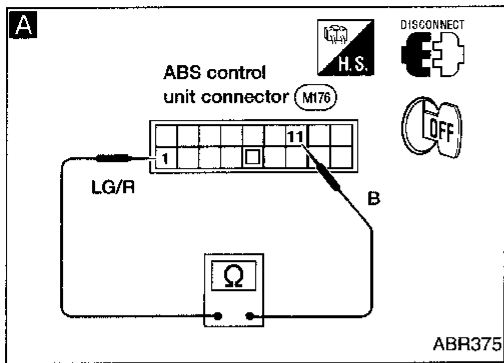

Diagnostic Procedure 7

ABS ACTUATOR ISO SOLENOID SHORT CIRCUIT OR OPEN (Warning lamp flashing number 2 or 7)

Remove battery negative terminal connector.

A
CHECK ISO SOLENOID.
Check resistance between ABS control unit connector terminals ① and ⑪.
Resistance: Approximately 4Ω

OK → Replace ABS control unit.

NG
CHECK ABS CONTROL UNIT GROUND CIRCUIT.
Go to **Diagnostic Procedure 6, BR-44.**

NG → Repair harness or connector.

B
CHECK ABS ACTUATOR GROUND CIRCUIT.
Check harness continuity between ABS actuator terminal ④ and suitable body ground.

OK → Repair harness or connectors.

NG
C
CHECK ISO SOLENOID.
Check resistance between ABS actuator connector terminals ① and ④.
Resistance: Approximately 4Ω

NG → Repair harness and connectors between ISO solenoid and ABS control unit.

OK
Replace ABS actuator.

Diagnostic Procedure 8

ABS ACTUATOR ISO SOLENOID BLOCKED (Warning lamp flashing number 4)

Remove battery negative terminal connector.

A
CHECK ABS ACTUATOR SWITCH.
Does continuity exist between ABS control unit terminal ④ and suitable body ground?
Continuity should not exist.

OK → Replace ABS control unit.

NG
B
Does continuity exist between ABS actuator terminal ② and suitable body ground?
Continuity should not exist.

NG → Replace ABS actuator.

OK
Repair harness and connectors between ABS actuator and ABS control unit.

Diagnostic Procedure 9

ABS ACTUATOR DUMP SOLENOID SHORT CIRCUIT OR OPEN (Warning lamp flashing number 3 or 8)

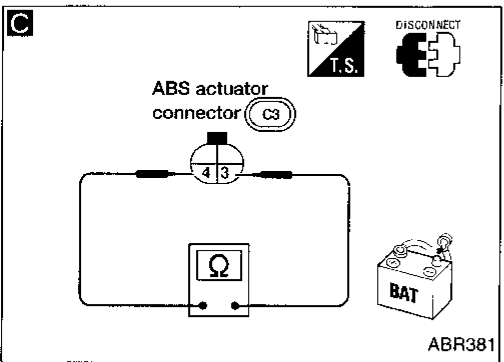
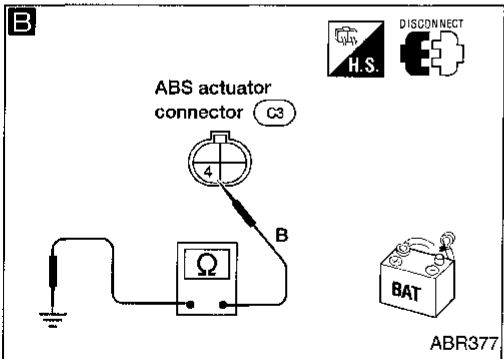
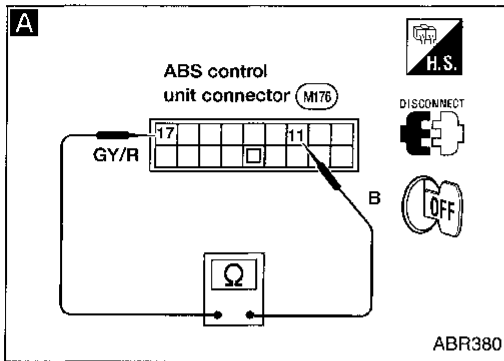

Remove battery negative terminal connector.

A

CHECK DUMP SOLENOID.
Check resistance between ABS control unit connector terminals ⑰ and ⑪.

Resistance:
Approximately 1.5Ω

OK → Replace ABS control unit.

NG

CHECK ABS CONTROL UNIT GROUND CIRCUIT.
Go to **Diagnostic Procedure 6, BR-44.**

NG → Repair harness or connector.

OK

B

CHECK ABS ACTUATOR GROUND CIRCUIT.
Check harness continuity between ABS actuator terminal ④ and suitable body ground.

OK → Repair harness or connectors

NG

C

CHECK DUMP SOLENOID.
Check resistance between ABS actuator connector terminals ③ and ④.

Resistance:
Approximately 1.5Ω

OK → Repair harness or connectors between dump solenoid and ABS control unit.

NG

Replace ABS actuator.

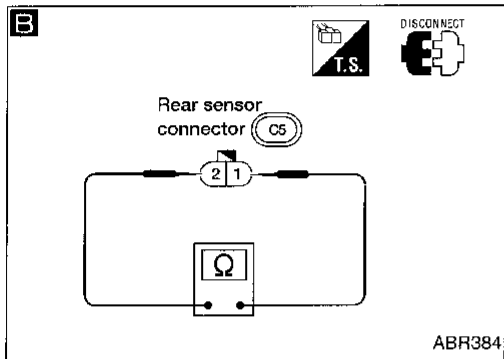
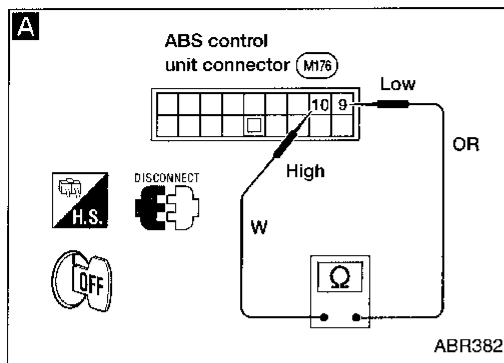

Diagnostic Procedure 10

REAR SENSOR OPEN OR SHORT CIRCUIT (Warning lamp flashing number 9 or 10)

Remove battery negative terminal connector.

A
CHECK REAR SENSOR.
 Check resistance between ABS control unit connector terminals ⑩ and ⑨.
Resistance:
 1.22 - 1.48 kΩ

OK → Replace ABS control unit.

B
 Check resistance between rear sensor unit connector terminals ② and ①.
Resistance:
 1.22 - 1.48 kΩ

OK → Repair harness or connectors between ABS control unit and rear sensor.

NG → Replace rear sensor unit.

Diagnostic Procedure 11

SENSOR SIGNAL ERRATIC (Warning lamp flashing number 6)

CHECK REAR SENSOR ROTOR TOOTH CONDITION.
 1. Remove propeller shaft.
 2. Remove companion flange, refer to "DISASSEMBLY" in PD section.
 3. Check rotor on companion flange.

NG → Replace rear sensor rotor with companion flange.

OK → Replace ABS control unit.

Diagnostic Procedure 12

ABS CONTROL UNIT (Warning lamp flashing 13, 14 or 15)

ABS control unit malfunction.

Replace ABS control unit.

GI
 MA
 EM
 LC
 EC
 FE
 CL
 MT
 AT
 TF
 PD
 FA
 RA
BR
 ST
 RS
 BT
 HA
 EL
 IDX

Diagnostic Procedure 13 Other (Warning lamp flashing 5)

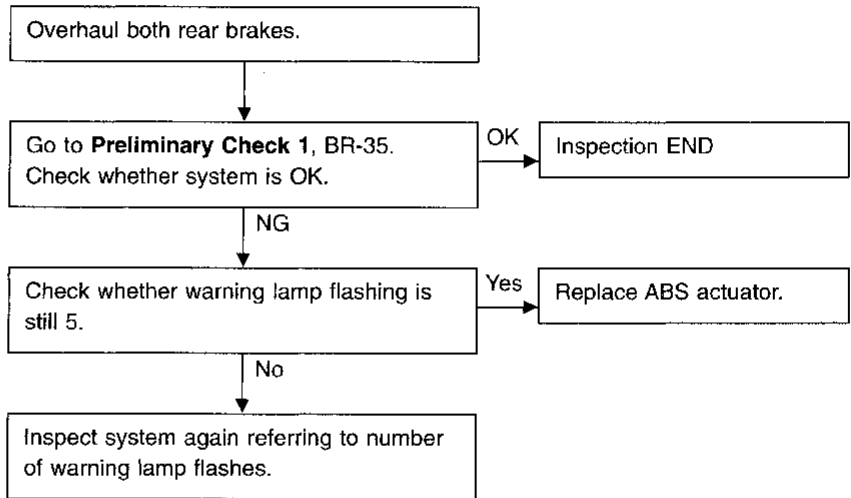

GI
MA
EM
LC
EC
FE
CL
MT
AT
TF
PD
FA
RA
BR
ST
RS
BT
HA
EL
IDX

Electrical Components Inspection REAR SENSOR UNIT AND ACTUATOR

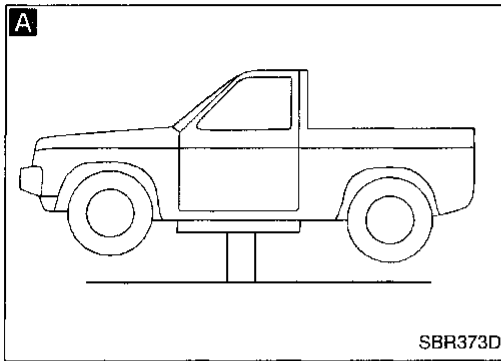

A

CHECK REAR SENSOR SIGNAL.

1. Raise vehicle. Confirm it is safe to rotate rear wheels.
2. Start engine and rotate rear wheels with transmission in D position or first gear position.
3. Check rear sensor signal voltage between control unit terminals ⑩ and ⑨ with AC voltmeter.

Voltage: 0.4V or more
M/T at 700 rpm
A/T at 850 rpm

C

CHECK REAR SENSOR ROTOR for following points:

- Tooth condition
- Installation on companion flange
- Deformation
- Wear
- Looseness

NG → Replace rear sensor rotor with companion flange.

OK → Replace rear sensor unit.

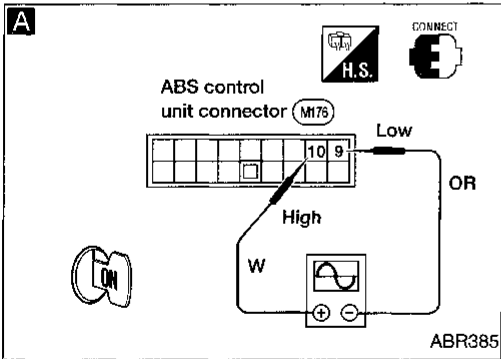

B

CHECK ABS ACTUATOR OPERATION.

Go to **Preliminary Check 2, BR-35.** Clicking noise sounds from actuator, when the ignition switch is turned on with battery cable connected.

D

CHECK PULSING VOLTAGE FROM ABS CONTROL UNIT.

Check pulsing voltage for ISO and DUMP solenoid between ABS control unit terminals ⑰ and ①①, and terminals ① and ①①.

Voltage: 0.3 - 3.5V for approx. 13 msec.

Use suitable digital voltmeter. Pulsing voltage appears when ABS warning lamp goes off after ignition is turned on.

NG → Replace ABS control unit.

OK → Replace ABS actuator.

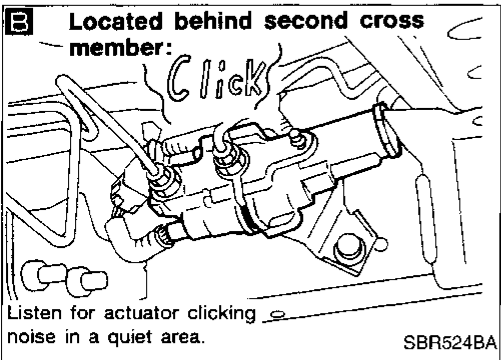

CHECK ABS OPERATION as follows:

1. Perform ABS check in a safe place without obstacles in the vicinity.
2. Drive the vehicle for more than one minute at speeds over 40 km/h (25 MPH) in the 2WD mode, then check that the warning lamp does not light on the instrument panel. After this, check for operation.
3. Check if ordinary braking effect occurs, and also check that the rear wheels do not lock when abrupt braking causes the front wheels lock.

OK → ABS is good condition.

NG → Replace ABS actuator.

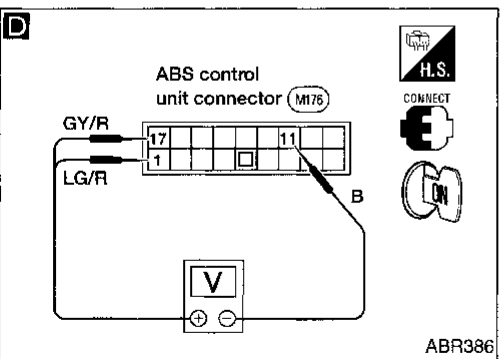
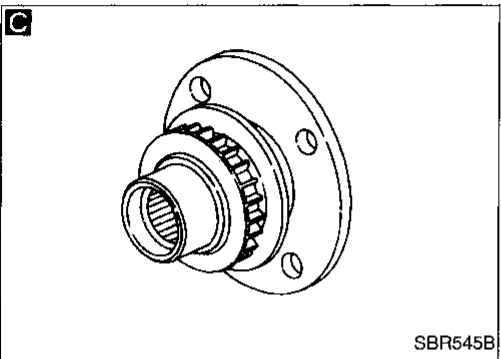

SERVICE DATA AND SPECIFICATIONS (SDS)

Inspection and Adjustment

DISC BRAKE

Unit: mm (in)		
Brake model	CL28VA	CL28VD
Pad wear limit		
Minimum thickness	2.0 (0.079)	
Rotor repair limit		
Minimum thickness	20.0 (0.787)	24.0 (0.945)

DRUM BRAKE

Unit: mm (in)		
Brake model	LT26B	LT30A
Lining wear limit		
Minimum thickness	1.5 (0.059)	
Drum repair limit		
Maximum inner diameter	261.5 (10.30)	296.5 (11.67)
Out-of-round limit	0.15 (0.0059)	

BRAKE PEDAL

Unit: mm (in)	
Free height "H"	
M/T	209 - 219 (8.23 - 8.62)
A/T	212 - 222 (8.35 - 8.74)
Depressed height "D" [under force of 490 N (50 kg, 110 lb) with engine running]	120.0 (4.72)
Clearance "C" between pedal stopper and threaded end of stop lamp switch or ASCD switch	0.3 - 1.0 (0.012 - 0.039)
Pedal free play	
At clevis	1.0 - 3.0 (0.039 - 0.118)
At pedal pad	4 - 12 (0.16 - 0.47)

*: Measured from surface of melt sheet to pedal pad.

PARKING BRAKE CONTROL

Control type	Stick lever
Lever stroke [under force of 196 N (20 kg, 44 lb)]	10 - 12
Lever stroke when warning switch comes on	1

GI

MA

EM

LC

EC

FE

CL

*: Measured from surface of melt sheet to pedal pad.

MT

AT

TF

PD

FA

RA

BR

ST

RS

BT

HA

EL

IDX